

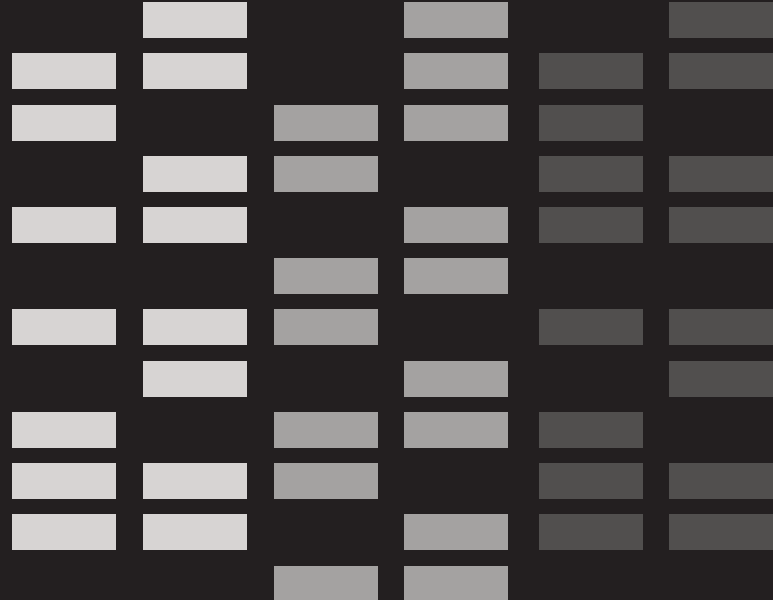

# OX MKII

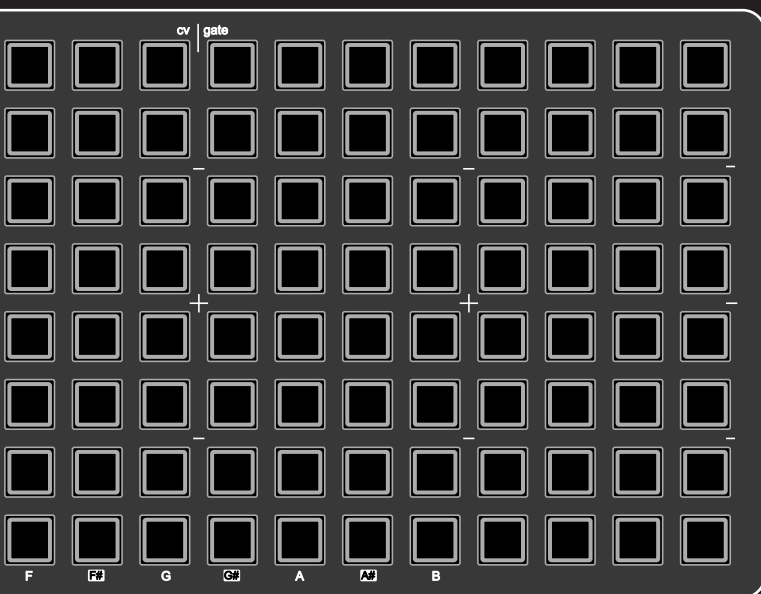

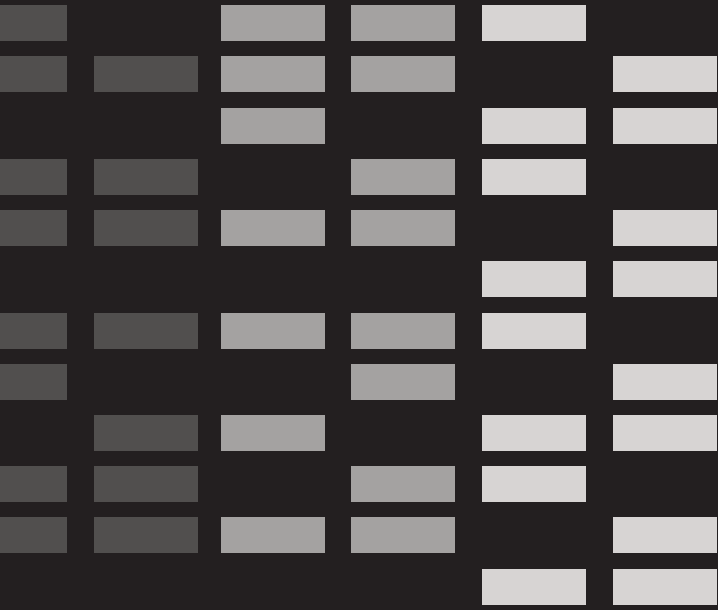

# Contents

1. Overview	
1.1 Introduction.....	2
1.2 What's In The Box .....	3
1.3 How To Use This Manual.....	4
1.4 Hardware Overview .....	5
1.5 Glossary of Terms.....	8
1.6 Architecture .....	9
1.7 Power & Charging .....	10
1.8 Starting with Projects.....	11
1.9 Project Management .....	14
1.10 Display and Control Conventions .....	16
1.11 Grid Conventions .....	18
2. Workflow	
2.1 Example Generic Workflow. ....	22
2.2 A Simple Expressive Sequence.....	23
2.3 Chords, Repetitions and Harmonization.....	25
2.4 Multitrack for Drums. ....	27
2.5 Magic of Modulation Lanes .....	29
3. Sequencer Basics	
3.1 What is a Sequencer? .....	34
3.2 Navigating the Sequencers .....	35
3.3 Navigating the Sequencer & Step Parameters.....	38
3.4 Transport Controls .....	40
3.5 Mute and Activation Behavior .....	42
3.6 Sequencing Steps .....	43

# Contents

3.7 Global Sequencer View Parameters .....	44
3.8 Velocity .....	46
3.9 Gate .....	47
3.10 Repeat & Retrigger .....	48
3.11 Trigger Probability .....	51
3.12 Tempo .....	54
3.13 Swing .....	55
3.14 Scale and Root .....	56
3.15 Sequencer Behavior .....	59
4. Creating Patterns	
4.1 Pattern Length .....	64
4.2 Time Division .....	66
4.3 Playback Direction .....	69
4.4 Shifting & Copying Steps .....	70
4.5 Clearing Steps .....	72
4.6 Nudge Sequencer Timing .....	73
4.7 Time Bend Sequencer Speed .....	74
4.8 Swing .....	75
4.9 Groove .....	76
4.10 Euclidean Pattern Generator .....	78
4.11 Random Generator .....	82
4.12 Recording Patterns .....	84
4.13 Managing Patterns .....	88
4.14 Pattern Templates .....	93

# Contents

5. Performance Tools	
5.1 Keyboard View .....	98
5.2 Looping Patterns .....	100
5.3 Arpeggiators .....	102
5.4 Flow .....	108
5.5 Roller .....	110
5.6 Random Perform .....	111
5.7 Perform.....	113
5.8 Snapshots .....	120
5.9 Other Tools .....	121
6. Modes	
6.1 Sequencer Mode Overview .....	124
6.2 General Sequencer Setup .....	126
6.3 Mono Sequencer Mode .....	128
6.4 Poly Sequencer Mode .....	131
6.5 Multitrack Sequencer Mode.....	137
6.6 Multitrack Generators .....	145
6.7 Chord Sequencer Mode .....	148
6.8 Stochastic Sequencer Mode .....	157
6.9 Matriceal Sequencer Mode .....	162
6.10 Domino Sequencer Mode.....	177
6.11 Saga Sequencer Mode .....	181
6.12 MIDI Player Sequencer Mode .....	184
6.13 Accumulator.....	186

# Contents

6.14 Channel Multiplex .....	189
6.15 Harmonizer .....	190
7. Modulation	
7.1 Modulation Overview .....	196
7.2 Modulation Lane Controls .....	197
7.3 Modulation Steps .....	202
7.4 Recording Modulation .....	203
7.5 Modulation Matrix .....	205
7.6 CV Input Modulation .....	208
7.7 MIDI Modulation .....	209
7.8 LFO Modulation .....	210
7.9 Modulation Destination Reference .....	212
7.10 Quick Assign .....	219
8. Arranger	
8.1 Arranger Terminology .....	222
8.2 Songs & Arrangement Structure .....	223
8.3 Arranger View .....	224
8.4 Creating and Editing a Song .....	225
8.5 Playing and Controlling a Song .....	229
8.6 Master Lane & Clip Launch .....	231
8.7 Program Change & Bank Change .....	232
8.8 Editing Slots .....	233

# Contents

9. Connectivity	
9.1 CV & Gate Output Configuration .....	236
9.2 CV Output Options .....	238
9.3 Gate Output Options .....	243
9.4 Analog Drum Application .....	248
9.5 Analog Synth Voice .....	249
9.6 Analog Clock I/O.....	250
9.7 OXI Pipe MKII Connections.....	251
9.8 MIDI Connectivity .....	252
9.9 MIDI Ports & Channels.....	256
9.10 Synchronization.....	257
9.11 MIDI Input Monitor .....	259
9.12 Instrument Definitions.....	260
10. System	
10.1 OXI App.....	266
10.2 SD Card.....	269
10.3 Firmware Update.....	270
10.4 Troubleshooting Updates .....	271
10.5 Sequencer Interface LEDs & Colors .....	272
10.6 Analog Calibration .....	273
10.7 System Settings & Config Summary .....	275
10.8 Quick Reference Shortcuts .....	278



# Overview

The journey of learning any new instrument starts by getting hands on with the device and in parallel accessing a reference, quick start or guide to help speed things up and develop an effective workflow. These resources are valuable tools and, combined with the community of videos, tutorials, and forums, support an OXI ecosystem that helps get the best out of our instruments. We want you to make great music. Exploring a new instrument and its manuals for the first time can be fun and informative, but take your time! A lot is going on in the OXI ONE, and attempting to master every aspect should not be the goal 'right off the bat.' This manual is designed to appeal to various learning styles, whether from visual graphic aids, walkthroughs, or just a quick reference; we try to support everyone. You can rest assured that all relevant information to get the most out of your OXI ONE sequencer quickly has been assembled here for convenient referencing. Read cover to cover or drop in and out to suit your style whenever needed. An initial read-through of a manual can build a strong information base that will be helpful moving forward. This is when you'll first become acquainted with the parameters of your new instrument, the tools at your disposal, and how they interact with each other. Wherever you are on the journey to mastering the OXI ONE sequencer, this manual has something to offer, whether on day 1 or day 1,000. Build your knowledge and skills through hands-on experience; this manual will supplement and help along the way. We aim to take a user-orientated approach, so there should be something of interest for everyone, but we also encourage your exploration and to follow your own individual journey. The important thing is that you're making great music, being creative, and having fun!

# 1 Overview

---

## 1.1 Introduction

ONE is an advanced performance sequencer which can form the centre piece of any studio or live setup. ONE consists of 8 independent sequencers, each of which can be configured with one of 6 sequencer modes. Whether standard drum programming, controlling a polysynth or creating generative patterns ONE has it covered. An extensive IO landscape also ensure full integration with various rack and desktop gear using the MIDI TRS, Bluetooth or USB interface or the 8 analog CV/Gate channels perfect for Eurorack.

ONE is a sequencer and in itself does not generate any audio output. Audio is generated from the connected devices where ONE will control the pattern sequences.

### Specifications

#### Electrical specifications:

- 5V DC 1.7A (USB type C supply)
- Li-Po Battery 2200mAh

#### Radio equipment:

- Bluetooth 5.0, 2.4GHz, Tx Max: 4 dBm

#### Mechanical specifications:

- Aluminium chassis & Silicone buttons
- Dimensions: 375 x 130 x 19mm
- Weight: 950 gr.

#### Operating temperature:

- 10 °C to 36 °C

### Inputs & Outputs

- USB C for 5V power supply and MIDI USB. It also charges the internal Li battery
- MIDI TRS input & output (Din adapter included). MIDI Out is 5V, MIDI IN accepts 5V and 3.3V
- MIDI Bluetooth BLE 5.0 bidirectional, peripheral and central roles.
- CV's (1 to 8) outputs: from -3V to 5V.
- GATE (1 to 8) outputs: 5V or 10V configurable.
- Clock Out & Clock In. Also CV In 2.
- CV Input. CV In 1.
- Mini HDMI Connector for pipe interface

## 1.2 What's In The Box

Supplied with the device are the following components:-

- 1 x OXI ONE MKII Sequencer device.
- 1 x OXI ONE MKII Protective Case.
- 1 x USB Type A to USB Type C cable.
- 1 x MIDI TRS Adapter - Type 'A'.
- 1 x microSD Card.
- 1 x Quick start instruction leaflet.

The following items are optionally available accessories compatible with ONE that may be described further in this manual. These are not supplied with the device but are available separately from OXI or an OXI retailer.

- TRS to DIN5 Clock adaptor (available in grey color). Exposes ONE's Clock and Start-Stop IN and OUT to other gear's DIN SYNC ports
- TRS to Dual TS stereo splitter (available in pink color, black or red). Splits the Clock and Reset outputs of the ONE in two mono outputs. Splits the Clock/Gate IN and Reset/CV IN inputs in two mono inputs.
- OXI Split MKII: increases the number of MIDI Outputs available.
- OXI Pipe MKII: Eurorack module to break out the CV/Gate outputs.
- 3.5mm illuminated TS Patch cables.

Visit the OXI store [here](#) for further information.

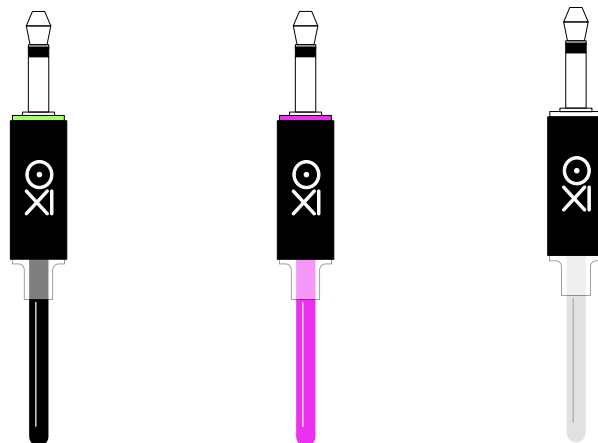

## 1.3 How To Use This Manual

This manual combines a formal reference with detailed instructions, illustrations, guides, workflows and tips for your device. You can add your own notes which personalises this into a comprehensive and unique guide book. For clarity, OXI ONE MKII device will simply be called ONE in this manual.

Icons and graphics will be used in the diagrams that reflect the faceplate of the device. Any walkthroughs and instructions will refer to the functions in text format.

(Knob 1)

Rounded parentheses represent the four context sensitive, encoder knobs. The text contained in the parenthesis will represent the function in focus to edit and it will be preceded by the command to take. For example, turn (Vel) to adjust the left knob velocity parameter. Encoders will be referred to as 'knobs'

[Play]

Front panel buttons with dedicated functions are detailed in square parenthesis. The button is preceded by the command, for example, press [Play]. Some panel buttons are only labelled with an icon. When referencing a generic grid pad button, the text 'pad' is used. Often the function is also explained in the guide.

[Shift] + (BPM)

Functions which require two button operations simultaneously are presented with a '+' symbol between each button. For example, press [Shift] + turn (BPM).

[Shift]

Buttons labelled on the panel in coloured text, typically in the lower part of the button or colored icons are commands that are accessed in conjunction with the shift button. For example, hold [Shift] + press [FLOW] to open the groove menu.

Topics will be relevant to all sequencer modes unless stated by the tags representing each of the 9 sequencer modes. **MO PO MT CH SC MC DM PY SA**

### Examples



Sequencer buttons. Described as seq [1], seq [2], seq [3], seq [4] etc.



Shift button. Used in conjunction with other buttons. Example, hold [Shift] + seq [1] for sequencer settings. Can be configured in the config > workflow settings to set the button to latch on by double tapping.



Keyboard button. The primary function is [Keyboard], indicated by the icon. The secondary function accessed with shift. Example, hold [Shift] + press [Keyboard] will select the preview secondary options as labelled.



Pad button. Generically described as [Pad]. The context will also be described.

Your Notes Can be written in any designated note section

## 1.4 Hardware Overview

### Rear / Edge

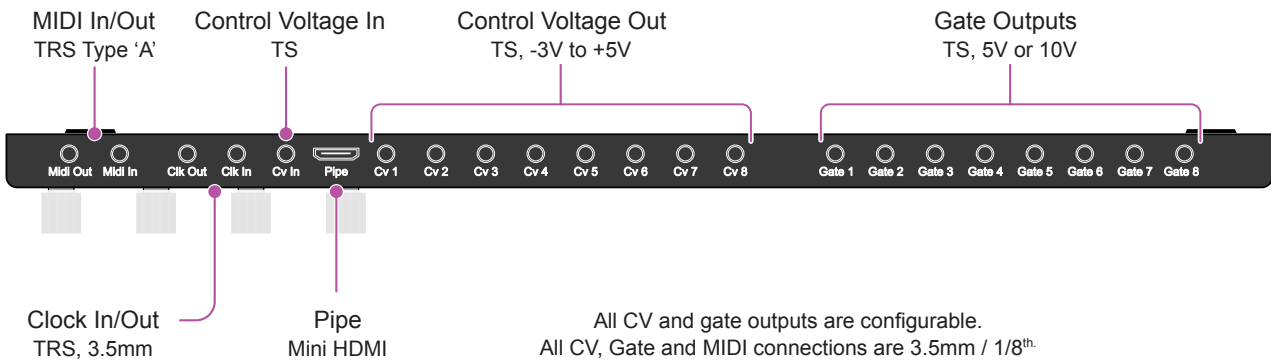

### Left / Side

### Right / Side

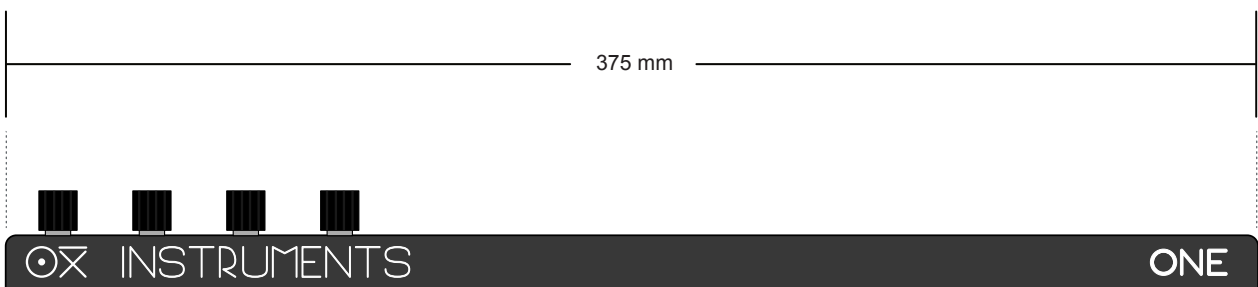
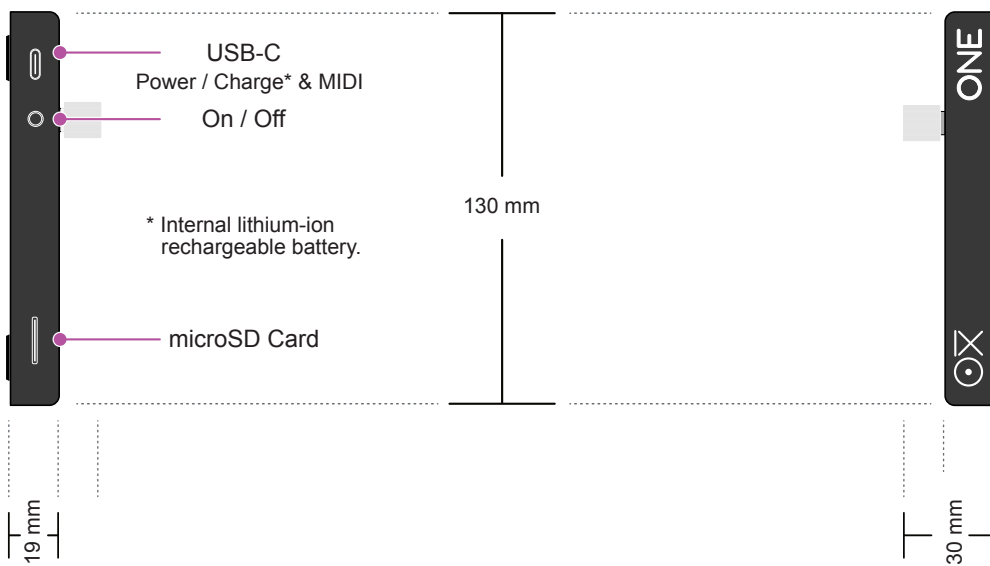

### Front / Edge

# 1 Overview

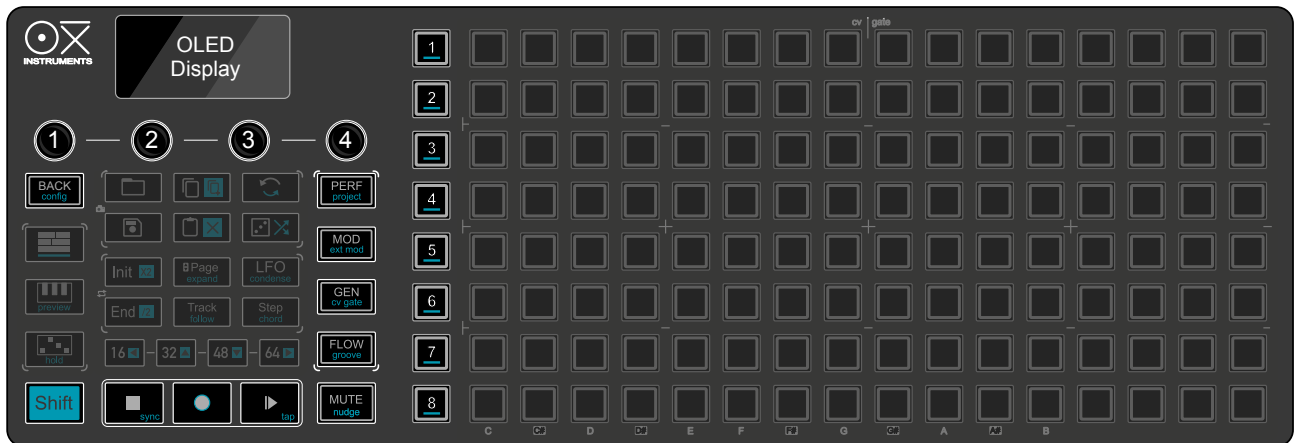

## Sequencers



### Sequencer 1 [1]

Selects the sequencer to view and edit.  
Hold [Shift] + [1] to access the sequencer settings.



Follow the same selection process for sequencers [2], [3], [4], [5], [6], [7] & [8] to view and edit.

Hold [Shift] + Press sequencer to access the selected sequencer settings.



### Sequencer 8 [8]

Selects sequencer to view and edit.

## Encoder Knobs



### Dynamic Knob 1 [Name]

First knob, far left.



### Dynamic Knob 2 [Name]

Knob is 2<sup>nd</sup> from left.



### Dynamic Knob 3 [Name]

Knob is 3<sup>rd</sup> from left.



### Dynamic Knob 4 [Name]

Knob is last one, located on the right.

Encoders are endless rotary push types. Tap an encoder to open menu options and in some cases hold to reset parameters. A knob's function is dynamic and will change based on the mode selected and parameter displayed.

## Transport & Shift



### Stop [Stop]

Stops all sequencers and resets to the first step.  
Double tap [Stop] to stop and reset all notes.



### Play / Pause / Reset [Play]

Plays the sequencer patterns.  
Hold [Shift] + Tap to register a tapped tempo value.



### Record [Rec]

Start recording from keyboard view or by using an external MIDI controller. Hold [Rec] + [Play] to enter step recording. Hold [Rec] + [Stop] to arm recording to start on note input.



### Shift [Shift]

Used in conjunction with other commands to access the turquoise colored secondary functions.

## Functions



### Mute & Nudge [Mute]

Mute / activate or unmute / deactivate a sequencer or track. Tap x2 to latch mute. Hold [Shift] + [Mute] to open the sequencer time offset and time bend options.



### Back & Config [Back]

Navigate and backup in menu structures. Double tap to return to the home sequencer view. Hold [Shift] + [Back] for the configuration menu.



### Perform & Project [Perf]

Open the performance view.  
Hold [Shift] + [Perf] to access the project management & SD functions.



### Generator & CV Gate [Gen]

Selects generator options.  
Hold [Shift] + [Gen] to access the CV gate mapping.



### Modulation & External Mod [Mod]

Enters MODulation lanes menu.  
Hold [Shift] + [Mod] to access external mod matrix.



### Flow & Groove [Flow]

Assign and trigger flow button punch-in/out events.  
Hold [Shift] + [Flow] to access the groove options.

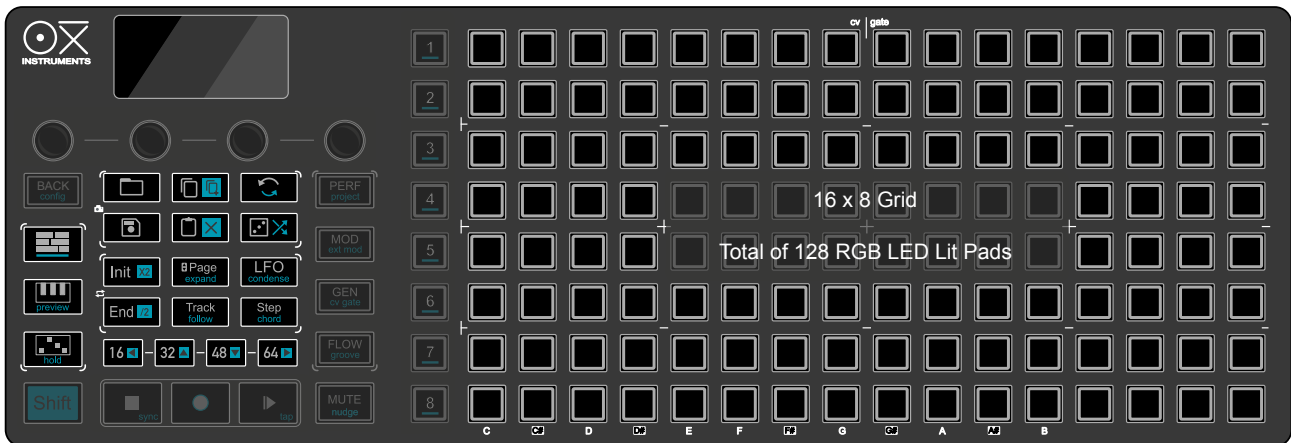

## Functions



**Arranger [Arranger]**  
Arranger view is used to create songs and loop patterns. [Shift] + [Arranger] to turn on or off.



**Arpeggiator [Arp]**  
Open the arpeggiator settings menu for the keyboard arp or the dedicated sequencers. Hold [Shift] + [Arp] to hold keyboard notes.



**Step & Chord [Step]**  
Opens the step parameter global menu. In chord mode, [Shift] + [Step] selects the global chord menu.



**Track & Follow [Page]**  
Opens the track menu. [Shift] + [Track] to select playhead follower on/off.



**Load [Load]**  
Loads one of the 20 projects or one of the 128 patterns. Hold [Shift] + [Load] to reload the current pattern.



**Copy & Duplicate [Copy]**  
Access to the copy command for various functions. [Shift] + [Copy] will duplicate the current set of steps.



**Initial start position [Init]**  
Sets the initial step or page position. Hold [Shift] + [Init] to double the seq time division.



**Grid page 1 & 5 [16]**  
Tap or double tap to select the 16 or 80 step range page. Hold [Shift] + Tap [16] moves the sequence 1 step left.



**Grid page 2 & 6 [32]**  
Tap or double tap to select the 32 or 96 step range page. Hold [Shift] + Tap [32] moves the sequence 1 step up.



**Undo & Redo [Undo]**  
Tap to undo each of the previous 15 commands. Hold [Shift] + [Undo] to redo the action.



**Keyboard [Keyboard]**  
Sets the grid into a playable, isomorphic or classic keyboard layout. [Shift] + [Keyboard] previews and auditions the external device when playing on ONE.



**LFO & Condense [LFO]**  
Select one of the two, per sequencer low frequency oscillator settings. Hold [Shift] + [LFO] to reduce the sequencer time division resolution by 2.



**Page & Expand [Page]**  
Navigates the available menu pages. [Shift] + [Page] increase time division resolution x2.



**Randomizer [Randomizer]**  
Performance randomizer. Hold [Shift] + [Randomizer] or tap x2 to select the random pattern generator.



**Save [Save]**  
Saves and manages projects or patterns. [Shift] + [Save] to quick save the project.



**Paste & Clear [Paste]**  
Paste from the clipboard for various functions. [Shift] + [Paste] will clear various functions.



**Final end position [End]**  
Sets the step or page end position. Hold [Shift] + [End] to halve the seq time division.



**Grid page 3 & 7 [48]**  
Tap or double tap to select the 32 or 114 step page. Hold [Shift] + Tap [48] moves the seq 1 step down.



**Grid page 4 & 8 [64]**  
Tap or double tap to select the 64 or 128 step page. Hold [Shift] + Tap [64] moves the seq 1 step right.

## 1.5 Glossary of Terms

While you may think this should be hidden at the back of this book, understanding the terminology applied when using ONE in an environment with other gear is helpful when getting started quickly. Becoming familiar with these terms early in the workflow makes sense to help embed your defined workflow and build knowledge as experience develops.

**Arrangement:** The structure of an entire song or sequence of patterns organised to play together, for example in an arrangement loop.

**BLE.** Shortened from Bluetooth Low Energy and is a technology for wireless communication between devices. BLE is a 'light' version of the full Bluetooth standard, typically used between close proximity devices such as the ONE and an iPad.

**Class Compliance:** Refers to direct USB compatibility of devices without a driver needed. Allows MIDI and Audio over USB. ONE is not an audio generating device but relies on compatible MIDI connectivity to another audio device.

**Clock:** A clock controls time based functions such as tempo or delay times in an audio effect. This is important for sequence timing and synchronization. ONE can be used as a primary clock or receive an external clock over MIDI or with Analog I/O.

**CV:** Shortened from control voltage. An analog technology used for communicating parameter values using voltage levels, with gear such as Eurorack modules.

**Gate:** A signal that is activated On or Off. For analog signals, this would be a high or low-voltage to activate a 'note on' signal. Gates differ from triggers because they operate with a longer pulse, which is better for note control. A shorter on/off trigger is preferred for drum signals.

**Grid:** The main 16 x 8 pad section used for sequencing pattern steps. Also used in some views to access various settings and controls.

**LFO:** Shortened from Low Frequency Oscillator, an LFO generates a wave shape signal used to modulate other internal or external parameters to add interest and movement.

**MIDI:** Musical Instrument Digital Interface is a protocol used to communicate between audio devices typically via dedicate directional In/Out connections or by using a USB connection. ONE can also operate MIDI over USB, TRS or Bluetooth.

**Parameter:** An individual function and control element that can be adjusted to affect the sequencer operation.

**Pattern:** The main sequencing building blocks containing a series of steps to create a rhythmic or melodic sequence or series of parameter changes. ONE has a maximum of 128 patterns covering all sequencers.

**Preset:** A stored configuration, typically for designed sounds and effects that can be recalled later for example to an instrument sound.

**Project:** The highest order of structure in ONE. An overall container that stores the 8 sequencers, parameter settings, patterns, and songs. ONE has 20 on-board projects but can save more to the micro SD card.

**Sequencer:** A function that enables the creation, control, and playback of melodic, beat, and parameter patterns. ONE has 8 independent sequencers, each with a configurable seq mode.

**Snapshot:** Captures and restores a temporary state of the 8 sequencers. Ideal for performing live.

**Song:** A series of organised or chained patterns that form an entire or longer composition.

**Step:** A step carries individual settings and timing used to trigger an event such as playing a note, activating a drum, and applying a parameter change. Steps are 'sequenced' in a pattern to create a melody or beat. Each sequencer has a maximum of 128 steps.

**Track:** A track in ONE is the end to end sequencing journey from step creation through to generating its physical outputs. The sequencer mode determines how many tracks are available for each.

**Voice:** The signal channel that generates a physical output in order to control a sound. Each note played simultaneously would typically occupy 1 voice and a triad chord would require 3 voices.

### 1.6 Architecture

The overall architecture and organisation of a project is illustrated as a guide. The diagrams below are for reference only and are not aimed to be exact technical schematics.

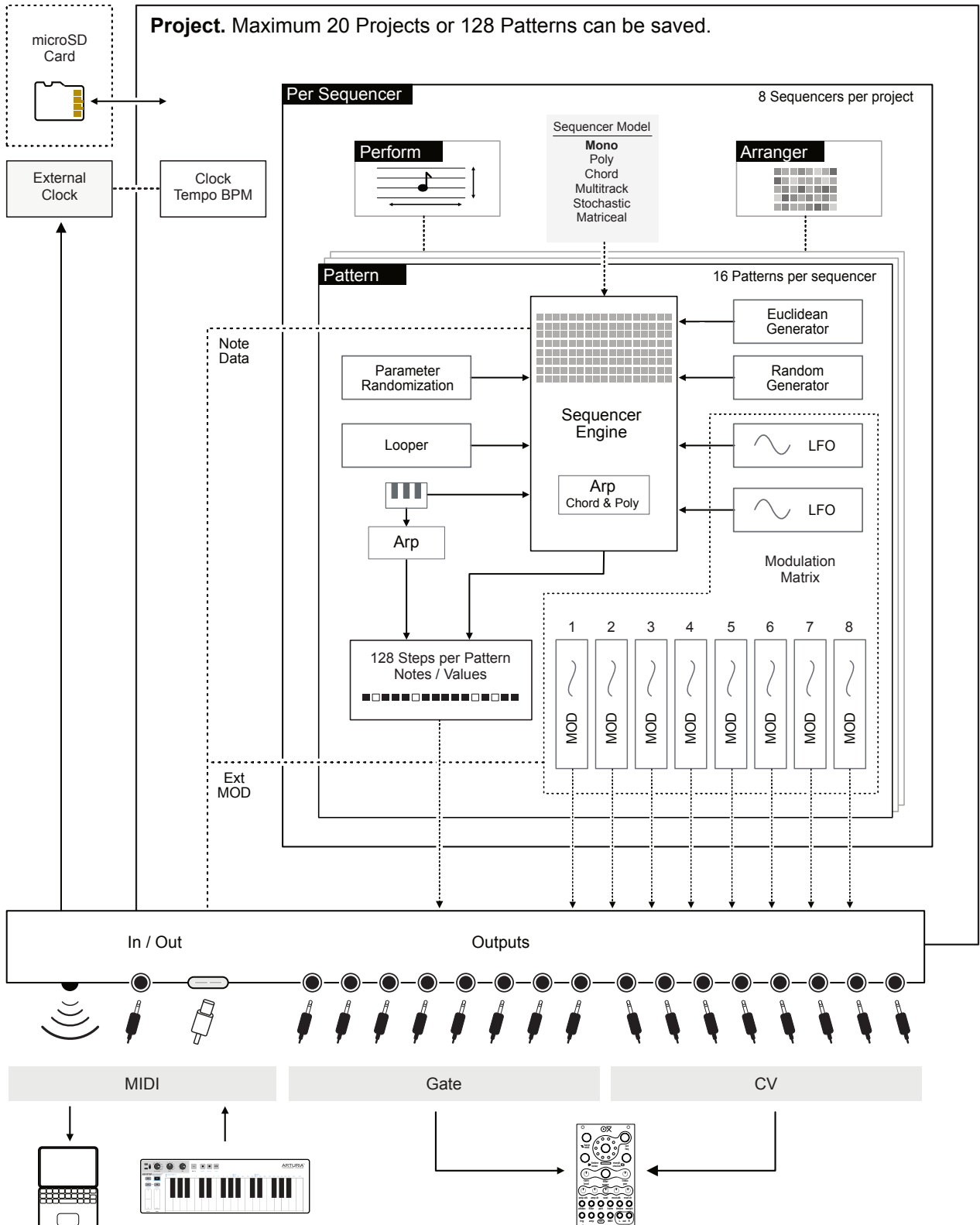

## 1.7 Power & Charging

A full battery charge is estimated to operate the ONE for up to 8 Hours although this may be shorter if ONE is also connected to power other USB devices. To power the device off or on, push the right side button. Configuration is accessed using [Shift] + [Back].

- 3 USB power connection**  
Connect the other end of the USB-C cable to the **ONE** USB Socket

- 1 microSD Card**  
Ensure the microSD card is inserted, pins facing up, before powering up **ONE**.

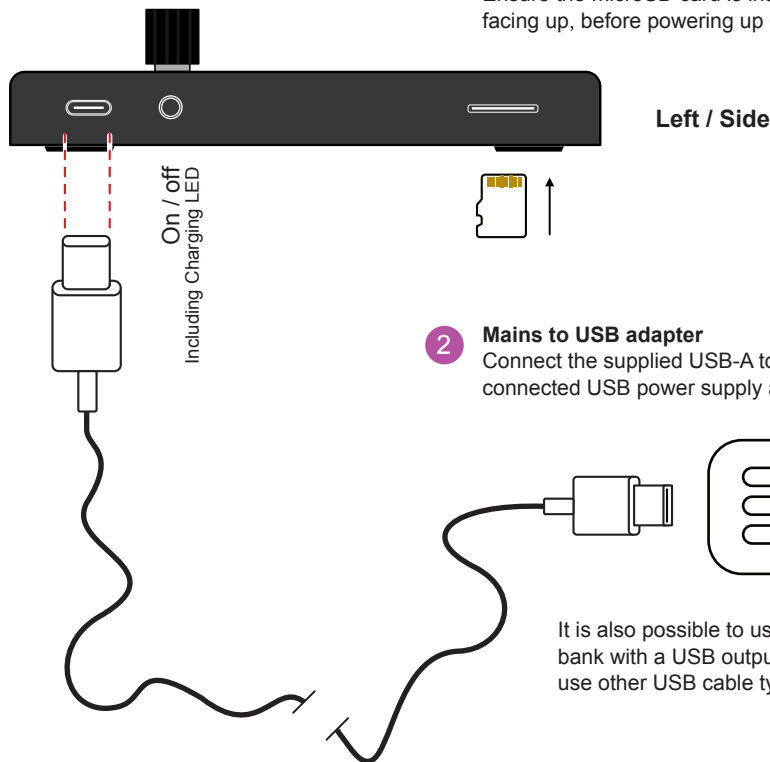

- 2 Mains to USB adapter**  
Connect the supplied USB-A to a mains connected USB power supply adapter.

It is also possible to use a power bank with a USB output and also use other USB cable types.

- 4 Turn On / Off**  
The ONE will charge from the power supply. To power the device on tap the left side button. The prior state when turn off will be restored. To power off, press the on / off button.

- 5 Check battery level**  
With the ONE turned on, the battery state can be checked on the top right of the main display page. This will indicate charge status and battery level. The On/Off button flashes when charging.

Main Display Example

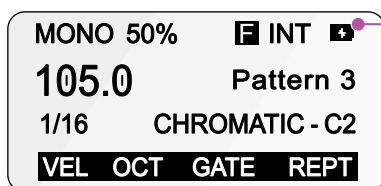

- Battery state indicator**
- When charging, the power indicator symbol flashes.
- When powered only by the battery, its current level is indicated.

## 1.8 Starting with Projects

A project is the highest order of structure in ONE and contains all sequencer data. One project must be active at a time and the previously autosaved project will be loaded automatically on power up. ONE has 20 on-board storage slots available for user created projects. More projects can be created and saved or loaded from the microSD card. Only modified data will be saved. Simply open an empty project or use the existing project slot to create a new project.

The convention in these menus is that knob 1 navigates projects, knob 2 patterns. In these menus pressing [Back] at anytime will backup, cancel or exit.

### ► Opening a Project

1. Open the load browser menu. Press [Load] button.
2. The display will show the 20 available project slots and will label the currently active project as 'Loaded'. In these menus the pad grid will represent the available patterns per sequencer.
3. Scroll to navigate the list. Turn (Knob 1). A ► symbol on the left of the list indicates the selected slot currently in focus.
4. Load from the selected slot. Press (Knob 1). The sub-menu 'Load Project' is displayed. Press (Knob 1) again to confirm and to load the project.

### ► Saving a Project

1. Open the save browser menu. Press [Save] button.
2. The display will show the 20 available project slots and will label the currently active project as 'Loaded'.
3. Scroll to navigate the list. Turn (Knob 1). A ► symbol on the left of the list indicates the selected slot currently in focus.
4. Save to the selected slot. Press (Knob 1). The sub-menu 'Save Project' is displayed along with the alternate options to rename or to clear. Ensure 'Save Project' is selected. Press (Knob 1) again to save the project.
5. You can also quick save the project to its current slot. Hold [Shift] + [Save].

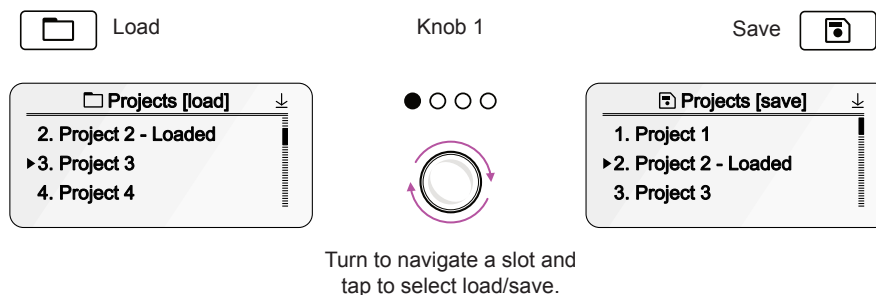

In the project load or save views, the grid pads display the patterns available per sequencer. Each coloured pad represents an existing pattern. Tap a pad to select and load the pattern for the respective sequencer, into the current project. Double tap a pad to save the current pattern to the selected pattern pad slot.

The save menu also offers options to rename or clear a current project or duplicate the current project to another slot. These options are found in the save confirmation sub-menu. These function can only be performed on the currently loaded project.

### ► Renaming a Project

1. Open the save browser menu. Press [Save] button.
2. The display will show the 20 available project slots and will label the currently active project as 'Loaded'.
3. Scroll to navigate to the active project. Turn (Knob 1). A ► symbol on the left of the list indicates the selected slot. Set to the 'Loaded' slot.
4. Open the sub-menu for the currently loaded project. Press (Knob 1). Ensure 'Rename' is selected by turning (Knob 1). Press (Knob 1) again to open the naming editor.
5. In the editor:
  - Knob 1 - Turn to scroll the selection of the alpha-numeric options.  
Tap to change the character.
  - Knob 2 - Turn to move the edit cursor in the text body being edited.  
Tap to backspace and clear the previous character.
  - Knob 3 - Press to cancel and return to the sub-menu.
  - Knob 4 - Press to confirm editing and complete the renaming.
6. Press [Back] at anytime to backup, cancel or exit.

Rename option found in the save sub-menu

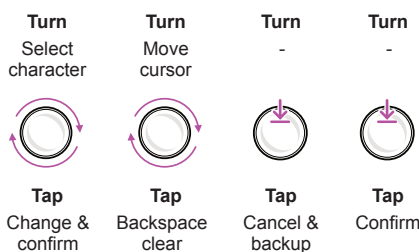
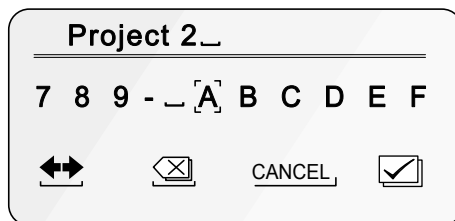

**► Erasing a Project**

1. Open the save browser menu. Press [Save] button.
2. The display will show the 20 available project slots and will label the currently active project as 'Loaded'.
3. Scroll to navigate to the active project to clear. Turn (Knob 1). A ► symbol on the left of the list indicates the selected slot.
4. Open the sub-menu for the selected project. Press (Knob 1). Ensure 'Clear project' is selected by turning (Knob 1). Press (Knob 1) again to clear the selected project.
5. Confirm clear. Turn (Knob 1) to select 'Yes' to confirm erasure or select 'No' to cancel. Press (Knob 1) on the selected option. Erasure will be confirmed.

**► Duplicate the Current Project to a New Slot**

1. Open the save browser menu. Press [Save] button.
2. The display will show the 20 available project slots and will label the currently active project as 'Loaded'.
3. Scroll to navigate to the new project slot in which to save a duplicate of the currently active project. Turn (Knob 1). A ► symbol on the left of the list indicates the selected slot.
4. Open the sub-menu for the selected project. Press (Knob 1). Ensure 'Duplic proj here' is selected by turning (Knob 1). Press (Knob 1) again to save the currently active project to the selected slot, thereby duplicating the project.
5. Confirm saving. Turn (Knob 1) to select 'Yes' to confirm copying or select 'No' to cancel. Press (Knob 1) on the selected option. Copy will be confirmed.

---

**Note**

Loading and saving does not interrupt a playing pattern. Some functions however do create a short milliseconds delay when in use and can affect playback performance. These commands are indicated by the ☺ symbol found in several menus

---

## 1.9 Project Management

Creating projects, quickly loading and saving projects is handled in the load and save menus. For more advanced project and pattern management is available in the project menu. This deals with the practical housekeeping topics and explains the use of the microSD card for extending project slot storage.

Project management and especially SD Card activities are covered here and other functions are covered in the appropriate section of the manual.



+



Open the project manager for the currently active project. Press [Back] to backup and exit from the menu.



Turn knob 1 to navigate the list of options. Tap knob 1 to select the option and its submenu.

Project Menu	
Shortcut	Description
Reload Project	Loads the previously saved version of the active project from <b>ONE's</b> memory slot, overwriting the one active in <b>ONE</b> .
Load from SD Card ☺	Loads a project from the microSD card 'projects' folder and overwrites the active project. Ensure the microSD is installed into the SD slot before powering up <b>ONE</b> .
Load MIDI file ☺	Loads a MIDI file into the MIDI Player sequencer. The .MID format files must be in the SD Card 'midifiles' folder.
Save project *	Saves the currently active project to the current slot in <b>ONE's</b> on-board memory.
Copy to SD card ☺	Copies the currently active project into the microSD card 'Projects' folder. Ensure the microSD is installed into the SD slot before powering up <b>ONE</b> .
Rename project *	Rename the currently active project.
Clear project *	Clear the currently active project to a default empty state. This option clears from the memory and also the microSD card so take care when clearing a project.
Rename current pattern	Renames the currently active pattern. The text editor will open and the name can be edited, same process as for projects.
Scale Master Seq	Selects the sequencer which will be used as the master reference for the global scale and root. Other sequencers will be automatically set to this master scale unless they are set to harmonizer or multitrack mode set to chromatic.
Arranger Launch Quantization	Sets the <u>arranger launch quantize</u> value for the arranger function. Separate to the global / load quantization.
Global Quantization	Sets the global quantization value.
Arranger Master Seq	Assigns the arranger master sequencer to Off or Seq 1-8.
Reset Proj Mappings	Resets the modulation mappings assigned for the project.

\* Same options and process as in the load and save menus. Follow the same process previously explained for using these functions.

While ONE can hold 20 project in its internal project slots, unlimited projects can be saved and managed on the microSD card. Ensure a microSD is installed into ONE with its pins up prior to powering up the device. This checks or configures the folder structure.

#### ► Copying a Project to the microSD Card

1. Open the 'Project' management menu. Hold [Shift] + Press [Perf].
2. Navigate by turning Knob 1 to 'Copy to SD Card'. A ► symbol on the left of the list indicates the selected option currently in focus. Using this option may cause a slight delay in ONE's performance while in progress as it accesses the card.
3. Copy the project to the microSD Card. Press (Knob 1). The sub-menu 'Cancel' or 'Yes' is displayed. Turn and Press (Knob 1) again to select and confirm.
4. All projects are stored in the 'Projects' folder on the microSD card and can be transferred to a PC/Mac or external drive for further backup and safe keeping. This is performed using a microSD card reader on the computed device.

#### ► Loading a Project from the microSD Card.

1. Open the 'Project' management menu. Hold [Shift] + Press [Perf].
2. Navigate by turning Knob 1 to 'Load to SD Card'. A ► symbol on the left of the list indicates the selected option currently in focus. Using this option may cause a slight delay in ONE's performance while in progress as it accesses the card.
3. Load the project from the microSD Card to a slot on ONE. Press (Knob 1). The list of available projects on the card are displayed. Turn and Press (Knob 1) again to select the project to load and confirm loading.

# 1 Overview

## 1.10 Display and Control Conventions

When powered up, ONE will revert to the project that was active before power down. The main sequencer view will be the default 'home' mode and will represent the currently selected sequencer settings.

### Main Screen - Sequencer View

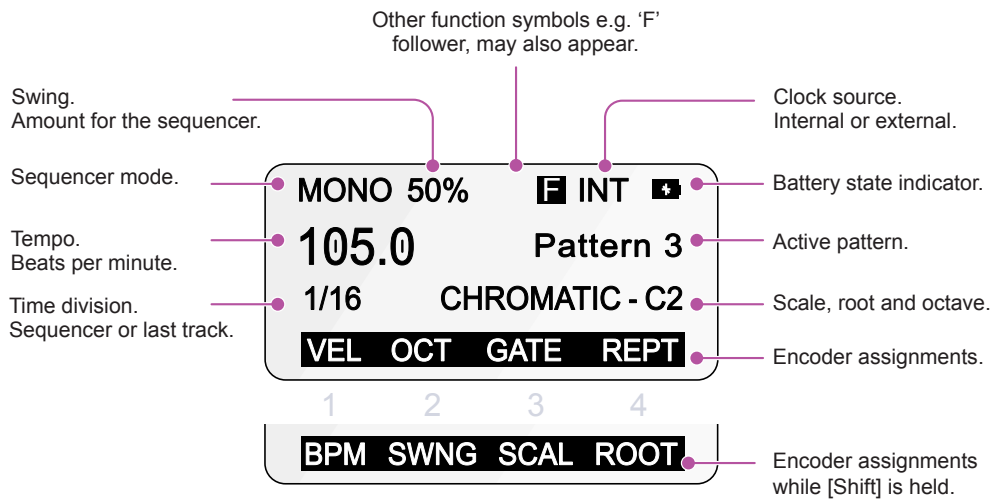

### Push Encoders - Sequencer View

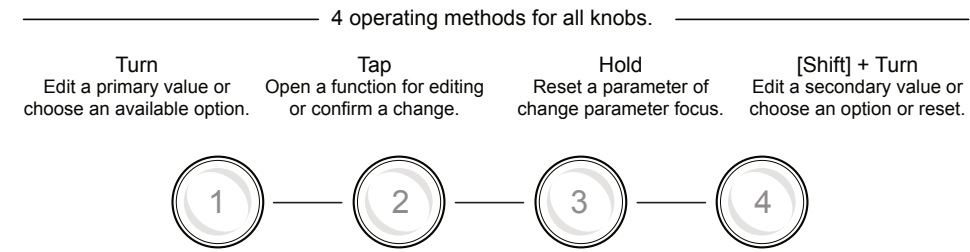

Available options are displayed on the screen above the encoder knobs. Some options open the grid pad editor for further changes to be made.

- Turn a knob or hold [Shift] + turn to directly edit a global value. Example: Turn (Vel) - Knob 1 to change the global velocity.
- + Hold [Pad] + turn (Knob) to edit a step value. Display will show the step values. Example: Hold [Pad] + turn (Vel) to change the velocity only for the selected step.
- Press to edit a primary function, maybe using the grid pads. Press to confirm a parameter change. Example: Press [Vel] to open the grid pad velocity editor. For some parameters, hold to reset its value.
- + Press to reset some secondary parameters while holding shift. In general, shift accesses the secondary parameters as displayed on the screen. Example: Hold [Shift] + press [BPM] to reset to the default value.

The speed of the knob rotation will determine the value resolution adjusted.

A number of generic controls can be used at various stages of the process when working with ONE. These are described in the specific context throughout the manual, but general operations are introduced here.

## Generic Controls



### Navigation and returning home

Press [Back] to move back in the **ONE** structure.

When deep into menus and sub-menus, double tap to quickly return to the 'home' sequencer view.



### Accessing secondary commands

Hold [Shift] plus another button to access its secondary options. These are either displayed on the menu or labelled in turquoise on the buttons.

x 2

It is also possible to assign a double tap command to lock the selection of the shift button on.

By default this is set to off but it can be set to on by selecting 'Yes' in the config > workflow menu options.



Hold

+



Tap

### Accessing the config menu

Hold [Shift] + Tap [Back] to access the configuration menu options. Several functions described will be dependant on the settings in these menu's. The commands used in the menu are:-

To navigate menus: Turn (Knob 1).

To enter a sub-menu or to confirm a selection or change: Press (Knob 1).

To backup in the menu: press [Back].

To save the config settings, hold [Shift] + [Back] in this menu.



Hold

+



Hold

### Accessing the MIDI Input monitor

Hold [Shift] + Hold [Back] > 2 Seconds opens the MIDI input monitor.



### Undo / Redo

Some commands can restore its previous state. Each press of the [Undo] button will reverse 1 command iteration up to a maximum of 15 steps. When a command is executed, the undo button will blink if an undo command is possible. Use [Shift] + [Undo] to redo a command.

## Preview Notes

When programming notes into the grid sequencer keyboard or by using pads, the notes are applied silently. This behavior can be changed to audition the output by triggering the CV or MIDI outputs. This allows the note audio to be previewed or remain silent each time a pad is pressed. This option can be toggled on or off using the keyboard button, secondary 'preview' function.



Shift

+



preview

### Select preview

Toggle on to audition any MIDI or CV outputs when placing notes on the piano roll grid. Button will be lit turquoise when on. When set to off, button is unlit and the steps can be placed silently.

# 1 Overview

## 1.11 Grid Conventions

The 16 x 8 Pad grid buttons form the central element for creating melodic patterns and beats. The pads are multi-functional in that they serve different purposes depending on the operating mode and view.

### Main Screen Default - Sequencer View



Select a sequencer to edit, [1] - [8]. Selected sequencer button flashes. Sequencer view allows patterns to be programmed into the grid using the pads to assign steps.

#### To adjust the grid note view range.

Vertical position



Tap then turn octave  $\uparrow\downarrow$  knob 2. Hold to reset. Alternatively, hold Seq [1] - [8] + turn (Knob 2)

When scrolling, the range is displayed alongside the label text -48 to +67 semitones

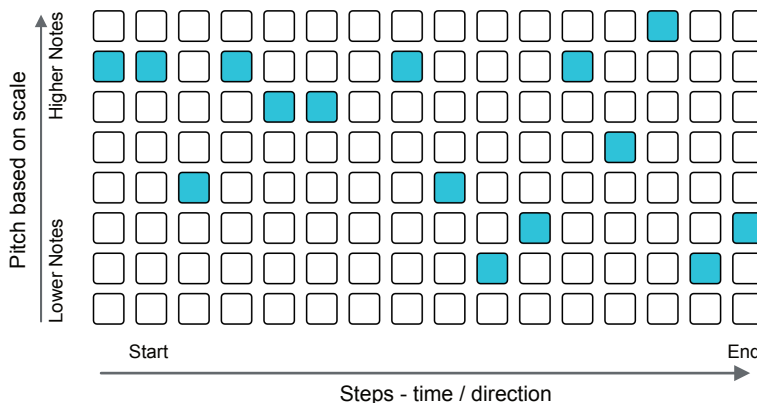

#### To adjust the steps in view.

Horizontal position



Tap or double tap a page button, 16/80, 32/96, 48/112, 64/128 when selecting a page.

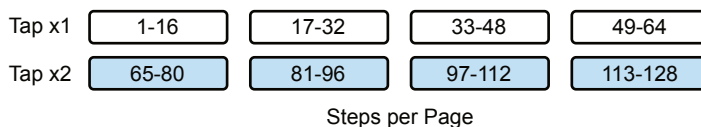

#### Activate or deactivate step.

Quickly tap [Pad].



#### Tie Multiple Steps.

Hold 1<sup>st</sup> [Pad] + Tap last [Pad].  
Ties all steps between the two pads.

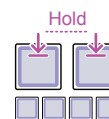

Access step parameters.  
Hold [Pad].



More step parameters.  
Hold [Shift] + Hold [Pad] or Hold [Pad] + Tap [Page]

Stp 2	J D2	1/3	
Vel	Oct	Gate	Trig
75	+0	50	100%



Use the 4 Knobs to edit the displayed step parameters.

Stp 2	Submenu			2/3
Rept	Durat	. . .		
No	x 1	±0%	±0%	
Offst	CVGlid	JRng	Rpt%	
0%	0%	Ost	100%	

**Rept**

Modulatable parameter tagged

Step settings can be set globally by directly using the knobs or assigned per step. These include frequently accessed options such as velocity, octave, gate and trig value.

The submenus offers many more additional and more advanced step options. Options are based on the sequencer mode. Tagged parameters can be modulated





# Workflow

One wise person once uttered the words, 'To start is to be halfway there'. So if we follow this mantra, getting started quickly will help to make music faster, more efficiently and build up your own knowledge and techniques. This will be your workflow, a process that fits best for you as a producer. While this may be personal and unique it helps to learn from others and from some best practices on how to get started and pick up some tips and tricks along the way. The manual alone will never get you to the ultimate position in your process, but it will help and contribute. This is where this section comes in. To help you get started quickly. You can master your art and the integration of ONE into your own setup and workflow now and even better going forwards. Here we take a less traditional approach. Instead of just giving the quick guide to 4 on the floor beats with maybe a bass line pitched in, we take a look at how ONE is used from an artists view point. Giving an insight into how ONE is used in a studio or live setup and their creative process. We introduce the inside track on how Oora integrates ONE into his workflow, how he uses some of the features to get tracks moving quickly and how this can lead to high quality, original and interesting music making. This runs in conjunction with Oora's ONE video tutorials. We could argue that mastering the art of ONE in music making in general is an aspiration that is never conquered, but equally some artists do get nearer to this magical point more than others. Oora is an inspiration in this area, someone who has helped develop ONE MKII into what it is today and who is prepared to share their own learnings with others. Take your time, adopt and adapt your process and make the journey fun.

## 2 Workflow

### 2.1 Example Generic Workflow.

Everyone will develop their own style and workflow when using OXI ONE. In order to get started here is a generic workflow guide to using ONE followed by some techniques and tips for the workflow process.



1	<b>New Project</b>	[Shift] + [Clear] for a full clear. Press [Load] to load an existing project or open a new, free project slot.
2	<b>Connect some gear</b>	Ensure an audio device such as a synth or drum machine or PC/Mac based DAW is connected. MIDI TRS, MIDI USB, MIDI Bluetooth or CV and Gate are all connectivity options.
3	<b>Configure the I/O</b>	Configure CV Gate using the grid, [Shift] + [Gen] for analog outputs. MIDI can be configured in the settings using [Shift] + [Back] for Config.
4	<b>Set up a sequencer</b>	Hold [Shift] + Seq [1] - [8] to select sequencer MIDI Channel and edit settings. Hold [Shift] + Knob 1 to set tempo.
	<b>Set the mode</b>	Page 1 - knob 4, sets Mono, Poly, Chord, Multi, Stochastic, or Matriceal.
	<b>Set the scale &amp; root</b>	Hold [Shift] + knob 3 to select a scale and Knob 4 for root note.
	<b>Set the length</b>	Hold [Init] + [Pad] or turn knob 2 for start, [End] + [Pad] or Knob 3 for end.
5	<b>Program notes</b>	Tap [Pad] to add or remove notes. Hold [Pad] + [Pad] to extend a note.
	<b>Generator</b>	Generates notes using an advanced Euclidean model. Tap [Gen]
	<b>Random Generator</b>	Applies notes randomly. Tap [Randomizer]
	<b>Keyboard</b>	The keyboard can be used to play and record notes, [Rec] + [Play].
6	<b>Edit notes</b>	Tap [Pad] to add or remove notes. Hold [Pad] + [Pad] to extend a note.
	<b>Set the pitch</b>	The grid layout may determine pitch in rows.
	<b>Edit Velocity</b>	Turn knob 1 to change the global velocity or [Pad] + turn to edit step.
	<b>Edit Gate</b>	Turn knob 3 to change the global gate length or [Pad] + turn to edit step.
7	<b>Modulation</b>	Modulation creates automation lanes or assigns LFOs to destination parameters on the external gear. Tap [Mod] or [LFO] to open the editor.
8	<b>Add Variations</b>	Many options exist to add variation to a pattern or improvise on-the-fly.
	<b>Set repeats</b>	Turn knob 4 or hold step [Pad] and turn knob 4.
	<b>Perform mode</b>	For live improvisation, press [Perf]. Transpose or affect all sequencers.
	<b>Probability</b>	Set a step probability. Hold [Pad] step + turn knob 4.
	<b>Flow</b>	Hold [Flow] + tap step [Pad] to apply a flow step. This will only trigger while holding the flow button when playing a sequence.
9	<b>Save Project</b>	Hold [Shift] + Tap [Save]

## 2.2 A Simple Expressive Sequence.

While Mono is a simple sequencer mode on OXI ONE MKII it is still is packed with powerful features and is the perfect starting point. Here we build an expressive and playable sequence and demonstrate how quick it can be to get creative and be inspired by OXI ONE.

Link to Oora's [workflow video here](#).

### ► Expressive Mono Sequencer Phrase

1. Ensure the synths are connected or for this example maybe connect to a DAW on a Mac or PC using MIDI. Set 3 tracks with instruments. Track 1 and 2 pulse / pluck style sounds and track 3 a bass pad. Each of the following sequencers will connect to these DAW tracks. Hold [Shift] + hold [Clear] each sequencer 1,2,3.

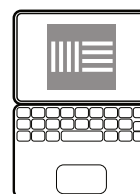

2. Set the project tempo. Hold [Shift] + turn (BPM) knob 1 to set to 120 beats per minute.

3. Select sequencer 1 and set to Mono mode. Tap Seq [1]. Hold [Shift] + [1] to open the sequencer settings. Turn (Mode) to set the sequencer to 'MONO'. This is in page 1 of 3 for SEQ 1.

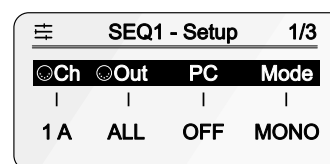

I. Set scale and root. While holding [Shift] + turn (Scal) knob 3 and (Root) knob 4. Set to Minor C2. The octave range is set with (Oct) knob 2.

II. Set the pattern length to 6 steps. Hold [End] + tap a pad in column 6. Alternatively knob 3 will change end step while holding [End]. The first step, set with [Init], should by default be 1.

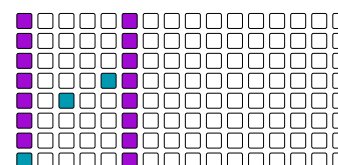

III. Add 3 steps as follows: Step 1 to C2, Step 3 to F2 and Step 5 to G2. To set these steps, columns represent steps, so use column 1,3 and 5. Rows represent the notes. The display shows the notes when tapping a pad to set the step note. Pads assigned with notes are lit.

IV. Hold Step 3 [Pad] + tap [Page] to select the accumulator page. While holding Step 3 [Pad], turn knob 1 (Amt) and set to +1st. Repeat for Step 5, setting the accumulator (Amt) to -1st.

V. Press [Play] to listen to the pattern created over the 6 step range.

4. Copy sequence 1 to sequencer 2. Hold [Copy] + tap Seq [1] then hold [Paste] + tap Seq [2]. The sequencer will be copied. If this is controlling a different track in the DAW it may need to change channel to match the DAW track. Channel is set for the sequencer in its settings, [Shift] + Seq [1], then turn (Ch) Knob 1.



## 2 Workflow

Link to Oora's [workflow video here](#).

### ► Expressive Mono Sequencer Phrase (Continued)

- Both sequencers play the same pattern. However pressing, [Perf] will open the performance page. This allows each of the sequencers to be transposed or rotated on the fly allowing ad libs and performances to be played out. Row 1 represents sequencer 1 and row 2, sequencer 2. The central white column is the original state, i.e. no transposition. Press a pad either side in these rows to transpose up or down. Hold [Shift] + [Pad] in row 1 and 2 to rotate patterns. Try these out and experiment with the performer while the sequencer plays.
- Create a third mono mode seq on track 3. Follow the previous steps to create and configure the sequencer as a mono mode sequencer. Add a long note for C2, bottom row. Hold Step 1 + tap step 16 to assign a tied note. This will represent a long bass pad and should be set to the channel for this track in the DAW.
- Lets add some variation with the flow button. Flow steps will only play while the flow button is held. Set steps 4 and 6 to notes G#2 and A#2 respectively. To dd these notes hold [Flow] + tap [Pad]. This assigns the steps as only flow steps. When playing the sequence, hold [Flow] to trigger these steps or release to play without these steps being triggered.
- Experiment once again in [Perf] mode to transpose sequencer patterns in harmony.
- Ensure the project is saved, hold [Shift] + tap [Save]. This will be a good starting point from which to progress further.

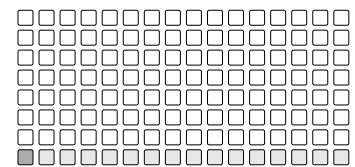
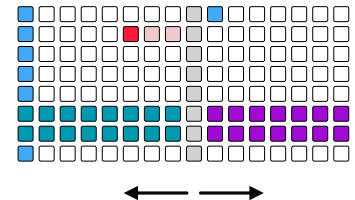

## 2.3 Chords, Repetitions and Harmonization.

Chord mode allows a melody of chords to be selected from a library of scales, chords and voicing available and patterns to be build from these. Add flow steps to create variations and link the pattern to the previous project to play all patterns in harmony.

Link to Oora's [workflow video here](#).

### ► Building a Chord Pattern

1. Start from the previous project.
2. Select sequencer 4 and set to Chord mode. Tap Seq [4]. Hold [Shift] + [4] to open the sequencer settings. Turn (Mode) to set the sequencer to 'CHRD'. This is in page 1 of 3 for SEQ 4.
3. Now to assemble some chords.

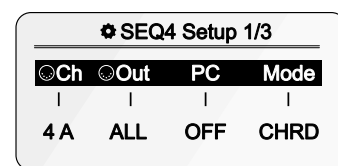

- I. In the main sequencer view, set scale and root. Hold [Shift] + turn (Scal) knob 3 and (Root) knob 4. Set to Minor C2. The octave range is set with (Oct) knob 2.

- II. Press [Keyboard] to open the scale pads and chord selector.



- III. Column 13 & 14 will select chord types, column 15, voicing / inversions and column 16 voice spread. The second top row in the 16<sup>th</sup> column will selected between the chord banks.

- IV. Audition the chords to find the ones to save. To store a chord, hold the pad keyboard for the chord and at the same time hold an empty, top row pad 1-12 for a few seconds. The pad will illuminate yellow when a chord is stored.

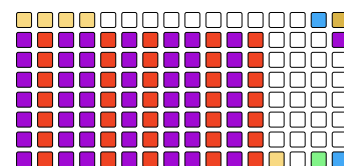

4. The stored chords can now be used to sequence a melody. To pick and place a chord from sequencer view, hold [Keyboard] to show the chord view page and tap a stored chord pad 1-12 top row. Release the [Keyboard] button and tap any step pad to place the selected chord on the grid. Repeat for other chords to build a melody.

5. Now consider adding more interest and variation with some repeats. The OXI ONE repeat engine offers a wide range of options to add repeats, spread their intervals, add ramps and more. Hold a chord step [Pad] + tap [Page] to select the step submenu for the repetition settings. While still holding the pad, turn knob 1 (Rept) to set repetitions.

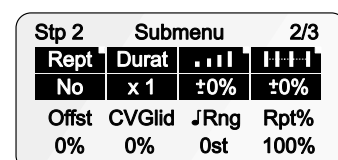

6. While still holding the step pad, try adjusting other parameters. Maybe set the repetition spacing with knob 4 and adjust the ramps with knob 3. Experiment while playing the chords.

## 2 Workflow

Link to Oora's [workflow video here](#).

### ► Building a Chord Pattern (Continued)

- An alternative control for repetitions is to press (Rept), knob 4 from the main sequencer screen. This will open the pad column editor for repeats. Tap [Pad] to add repeats and [Shift] + [Pad] will adjust repeat duration, indicated by the red lit pads.
- To use flow to trigger only selected step repetitions, hold the step to edit [Pad] + tap knob 4. This switches focus to edit the lower Rept% parameter in the step submenu. With the pad still held, turn knob 4 to set Rept% to 'Flow'. Now the repeats will only be applied when the [Flow] button is held.
- Let's link the chord sequencer playback to the mono sequencers playback in an harmonious way. First, select sequencer [1]. Set the scale using [Shift] + (Scal) knob 3 to 'HARMON S4'. This takes sequencer 1's harmonization lead from chord sequencer 4. Repeat for sequencer 2.
- Press [Perf] mode and experiment by transposing sequencer patterns. These will now play and transpose in harmony. The mono sequencers 1 & 2 will follow the harmonic lead of sequencer 4. Transposing the chord sequencer in the performer grid will control the chord and mono sequencers harmonization.
- Ensure the project is saved, hold [Shift] + tap [Save]. A good habit to get into for saving iterative development of the project.

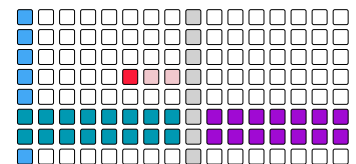
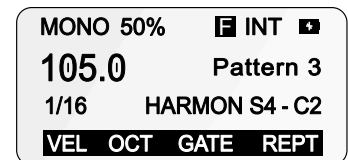
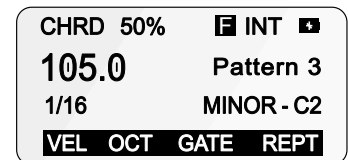

## 2.4 Multitrack for Drums.

Multitrack mode allows each row to act an independent sequencer. Individual MIDI channels can be set per row. If all sequencers were set to multitrack mode, OXI ONE would offer 64 tracks of sequencing. Lets create a drum pattern using the multitrack sequencer.

Link to Oora's [workflow video here](#).

### ► Building a Drum Pattern

1. Start from the previous project.
2. Select sequencer 5 and set to Multitrack mode. Tap Seq [5]. Hold [Shift] + [5] to open the sequencer settings. Turn (Mode) to set the sequencer to 'MULT'. This is in page 1 of 3 for SEQ 5.
3. Destination instruments can be configured using one MIDI channel per drum, for example kick on channel 5. However some instruments will respond to a single channel when each note represents a drum instrument. For example, Elektron Digitakt can be used with an individual note for each track. Both can be used in OXI ONE with a multitrack sequencer.
4. Setting up a multitrack track.
  - I. To open the track menu, hold Sequencer [5] + Press Column 1 [Pad] for the track to select. Alternatively, press [Track], then press column 1 [Pad] to select a track.
  - II. Turn (Ch) knob 1 to set the MIDI channel. This is for the selected track and not for the sequencer globally.
  - III. Hold [Shift] + tap [Keyboard] to set preview mode. Any sounds triggered from the MIDI output will be audible.
  - IV. Turn (Ofs) knob 2 to select a note offset. This is the note that the steps on the track will trigger and send to the MIDI channel. The note should represent the destination instrument, example 'C1'.
  - V. Repeat for all tracks to configure.
5. The behaviour when programming multitrack steps can be changed in the [Shift] + [Config] > workflow options. This depends on your personal preference:

Track Select priority in multitrack.

- Yes: First tap of a step will select the track to edit, then subsequent step taps will assign triggers to the chosen step.
- No: Trigger steps can be added immediately on any track when tapping a pad.

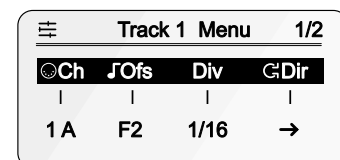
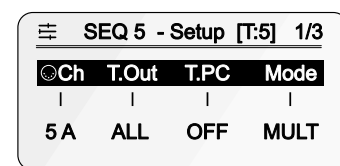

## 2 Workflow

5. Each track will represent a drum instrument, for example kick, snare, hi hat etc. Program steps on each track to create a drum pattern. Playing the track will help to test sequence options.
6. Each track is independent so lengths, time divisions and direction. Also variations in the sound can also be applied. For example:-
  - Tap (Vel) knob 1 when in the main page to control velocity of the selected track using the grid pad column editor.
  - Tap (Rept) knob 4 when in the main page to assign repeats to each step of the selected track using the grid pad column editor.
  - Tap (Gate) knob 3 and then turn to adjust all gate lengths for the selected track.
  - Hold [Shift] + press [Flow] to open the groove editor for the selected track. Grooves can be also be applied per track.
7. An alternative drum programming feature is the drum generator. This will automatically generate patterns for the first three tracks of a multitrack sequencer.
  - I. The track layout will automatically generate a kick on track 1, snare on track 2 and hats on track 3.
  - II. Hold [Random] + tap column 1 [Pad] for track 1, 2 and 3. This changes the status to drum generator tracks. Pads will be light bright blue when activated.
  - III. Set the track length to 32 steps. The drum generator is optimised for this length. Press [32] then hold [End] + tap the last column pad rows for the three tracks. Remember a multitrack can have the length setting per track.
  - IV. Press [Play] to generate patterns for these tracks.
8. Try using [Perf] to manage the drum tracks on the fly, using mutes and the preset variations to play ad libs and improvisations.

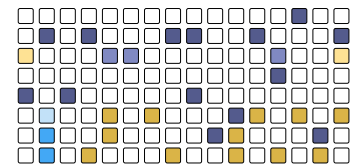

Patterns ☰			
Dens	X	Y	Chaos
OFF	0	64	5

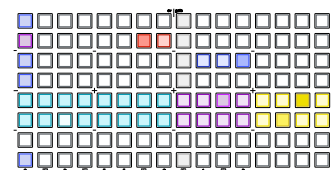

## 2.5 Magic of Modulation Lanes

Modulation is a term that refers to the control of a parameter to add movement and variation. For example a whammy bar on a guitar modulates the strings. In electronic music modulation is typically applied through envelopes and low frequency oscillators. This example focusses on a unique feature in OXI ONE, modulation lanes. These are track lanes dedicated to the modulation of external and internal parameters. Modulation is an application and setup specific. Therefore this workflow is only a general introduction to the principles of using modulation lanes in OXI ONE.

Link to Oora's [workflow video here](#).

### ► Instrument Definitions

- OXI ONE supports instrument definitions. What does this mean?  
Several profiles are loaded onto the device using the OXI App which act like MIDI presets. They provide the predefined mapping between the OXI ONE and the external device. This makes life easier where all CC controls are pre-configured and can simply be loaded to a track.
- As an example, create a 'POLY' track on say sequencer [6]. Follow the previous guidance for MIDI and sequencer configuration.
- To assign an instrument definition to seq 6, open the sequencer setup using [Shift] + Sequencer [6]. Tap [Page] button to choose page 3/3
- Then turn (Instr) knob 3. The loaded definitions are listed. New definitions can be added to the device from the app. As an example, choose OXI Instruments Coral, a Eurorack effect module.
- Connect OXI ONE to the Coral device, in this example using the USB connection option.
- Press [Mod] to view the mapped parameters for sequencer 6 and Coral device.

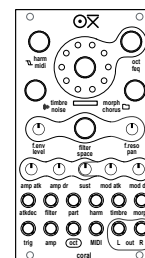
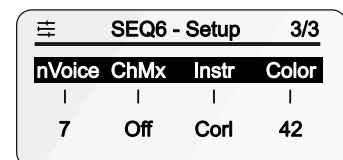
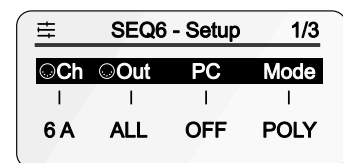

### ► Modulation Lanes

- Track 6, for this example will focus on modulating another device. In this case OXI Coral is the destination. It is assumed audio will be channelled through Coral, maybe as generated in one of the other workflow examples.
- On sequencer 6, press [Mod]. This opens the modulation function with 8 individual modulation lanes available. Think of these as modulation sequencers.
- If an instrument definition has been used the destinations are pre-mapped. If not [Shift] + [Mod] opens the modulation matrix settings.

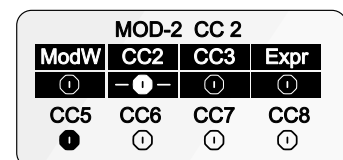

## 2 Workflow

- In the mod page, the 4 knobs represent a lane. Tap and hold a knob to turn the modulation lane on or off. Tap a knob to switch the focus between the upper 1-4 and lower 5-8 lanes.
- Turning a knob, when active, will adjust all the step modulation amount simultaneously. This is the value sent to the destination parameter from OXI ONE mod lane. Think of this as a set of steps, each adjusting the parameter value as the sequencer plays. Good examples are a filter cutoff, amount of reverb applied or the overall dry/wet mix of an effect.
- With a mod lane selected, the pads can be tapped to assign a value to each. Swiping across the pads to draw a modulation curve is possible. The grid pads act as column editors.
- To edit the modulation matrix for a specific lane, hold [Shift] + tap knob of the modulation lane to edit. A set of options for the CC destination as well as range settings are possible. Internal destinations can also be applied.
- Try setting loops or different time divisions. Also include more than one mod lane to modulate other device parameters in the same sequence but with independent shapes.
- To get even more advanced with modulation routing, it is possible to route and external input, say a CV control from a Eurorack device, through OXI ONE and out to a MIDI destination. Experiment with routings and controls in the [Shift] + [Mod] settings. This all depends of course on your hardware configurations and setups.

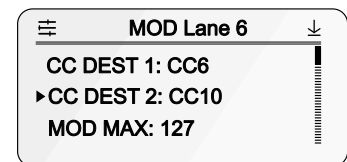
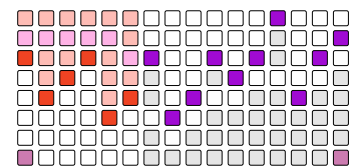





# Sequencer Basics

OXI ONE is a battery powered performance orientated sequencer, controller and composition tool. Equally at home on the stage for live performances or in the studio as a tool to help music production and sound design. ONE MKII is an evolution from the original model, Focusing heavily on evolving the sequencers, enhancing the workflow and enhancing with new features. ONE has 8 sequencers, each can be set to one of the unique sequencer modes. Whether creating basic bass lines, intricate melodies or composing drum beats the right tools are in the ONE toolkit. The three most fundamental areas when working with the sequencer are the user interface controls, the pad grid and the display screen. Some controls are dynamic and change based on the context. For example the 4 control rotary knobs will be assigned to parameters based on what function is selected and will display values to reflect these parameters. The grid is an important interface for creating patterns but is also used for editing parameters. The grid is multi purpose and will dynamically change its function to suit the sequencer mode and function selected. This section concentrates the basics of using the ONE sequencers. The content here is Focused on the more generic views and commands than can be applied in most sequencing environments. These are foundation topics that need to be familiarised before moving to more advanced detail later. The unique intricacies or specific details of an individual sequencing mode is covered later.

## 3 Sequencer Basics

### 3.1 What is a Sequencer?

From the perspective of ONE, a sequencer manages, creates, and enables editing of tracks and patterns. The sequencer is the operating environment when building patterns from steps and controls the general sequence playback and performance behavior. Only one sequencer can be selected at a time for editing and building tracks. There are a selection of sequencer operating modes. Each mode offers a set of options and workflow tools that aim to fit the specific creative context. For example, mono mode is ideal for monophonic melodic or bass melodies.

The output created in the sequencer is typically a track. A track is a series of patterns, step events, and parameter settings laid out over a musical timeline that controls the output to an external device. Typically, each sequencer will manage a track, although there are exceptions for multitrack and matriceal mode, where the sequencer modes can manage eight and four tracks respectively. It is helpful to think of a track as an instrument, although technically multiple instruments can be connected to a ONE output. It is a standard practice to have one track represent each external instrument. For example, a poly synth controlled by a poly mode sequencer, a multitrack sequencer with a kick drum, snare and hat using three tracks, and a bass synth in mono mode could be a simple configuration.

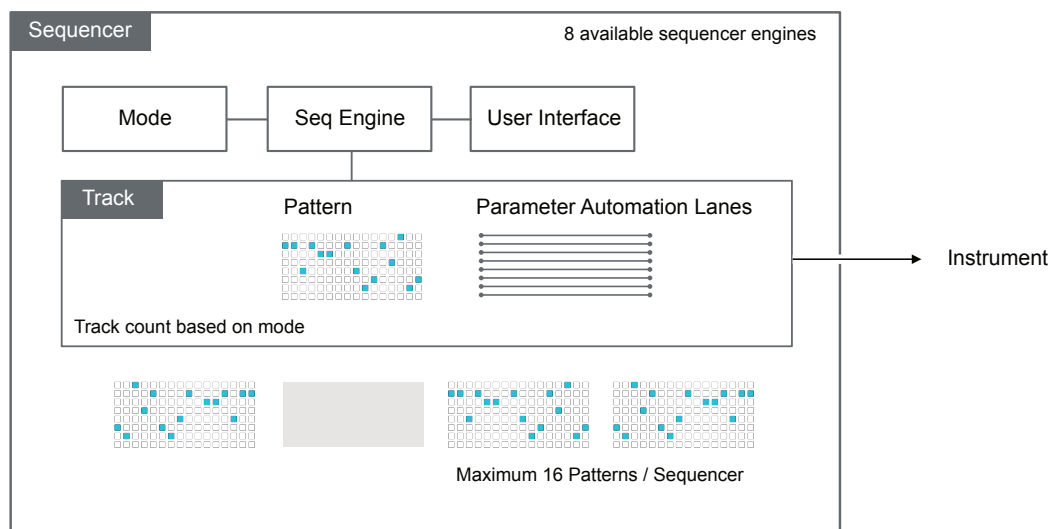

## 3.2 Navigating the Sequencers

The default home location upon start up is the sequencer view. A number of basic commands are generically accessible when working with the sequencers. Note that some controls are unique to the mode selected but typically the following commands are generic.

### Sequencer View & Command Options



#### Selecting a Sequencer

Press to select a sequencer to edit, tap [1] - [8]. Sequencer view allows patterns to be programmed into the grid using the pads to assign steps. The grid pad color will reflect the sequencer selected.

If the [Mute] button is latched on, pressing a sequencer will mute or unmute it. To select a sequencer while mute is latched on, hold [Shift] + tap [1] - [8].

Active / Unmuted	Inactive / Muted	
 Flashes white / color	 Soft static color	<b>Selected</b>
 Solid white	 Unitil	<b>Deselected</b>

#### Sequencer Status

The color of the sequencer buttons will indicate the current status of each sequencer. Only one sequencer can be selected at a time for editing and viewing. The selected, active sequencer will flash in time with the tempo BPM setting. (1)

Default grid pad colors per sequencer. These colors can be also be optionally applied to the sequencer buttons. This option is selected in the config > workflow settings.

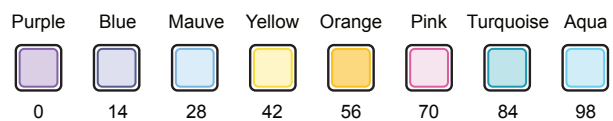

(1) The color scheme of the 1-8 sequencer pads can be selected in the config > workflow menu options. The color of the 1-8 pad when it is selected will therefore be based on the multi color or the default turquoise sequencer pad color scheme.

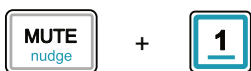

#### Activating / Muting a Sequencer

Hold [Mute] + tap [1] - [8]. To mute or unmute one or more sequencers. Transport bar is stopped.



When muting, holding [Mute] will delay the mute action for the chosen sequencer until the [Mute] button is released and then mute is activated immediately. The sequencer button will flash red to signify that the sequencer is armed pending mute. (2)



When unmuting, holding [Mute] will delay the unmute action for the chosen sequencer until the [Mute] button is released and is then based on punch in/out quantization. The sequencer button will flash green to signify that the sequencer is armed pending unmute. (2)

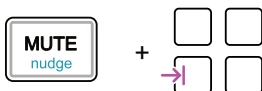

Hold [Mute] + tap any [Pad] in column 1 if the 16 x 8 grid. Muting / unmuting is applied immediately when using this method. Transport playhead continues.

(2) The default behavior is to mute the sequencer upon release of the mute button. The 'armed' mute state is indicated by the sequencer button color. The mute behavior can be changed in the config > performance settings.

## 3 Sequencer Basics

---

### Muting a Step

**MO PO MT CH**

**Mute / Unmute a Step.**  
Hold [Mute] + tap [Pad]s.

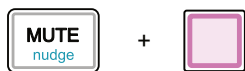

Operates in mono, poly, chord and multitrack mode.

Tip. Use the alternate method below when muting column 1 steps. Used in conjunction with the [Mute] button, column 1 is reserved for muting the active sequencer, indicated by soft white grid pads.

Hold [Pad] + tap (Vel).



Alternate option for muting. Use the velocity knob from within the step parameter page which will be displayed while holding a pad.

 Muted step pads will be dimly lit purple and the note icon is displayed in the header of the step screen when muted.

Sequencer view presents the grid as a series of steps formatted to suit the mode selected. For example, mono mode will show each column as a sequential step left to right in time and each row as a note pitch value from within the chosen note scale. Some views of the grid also represent parameter control settings and these are specific to the current operating context. Below are some generic structures and commands when using the grid for sequencers.

## Sequencer Grid View & Navigation

### To adjust the grid note view range.

Vertical position



Tap knob 2, then turn ↑↓



Alternatively, hold [Track] + turn (Knob 1).

Tap [Track] to open track menu, [Shift] + turning (Knob 1) will adjust in octave increments.

Up to 8 octaves can be navigated when scrolling through the grid rows vertically. Rows representing the start and end of an octave will be illuminated when adjusting the octave view.

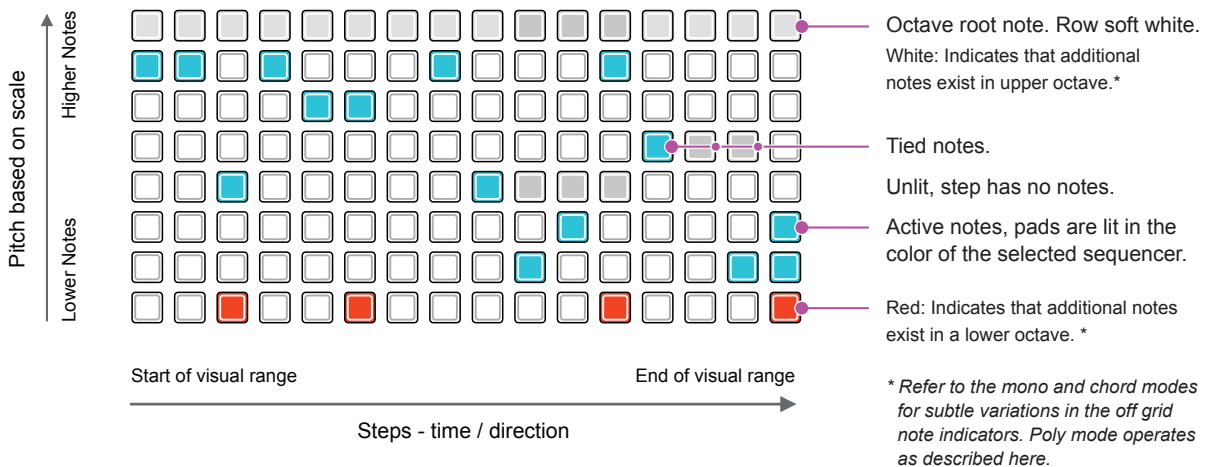

### To adjust the steps in view.

Horizontal position



Tap a page button to navigate step ranges 16, 32, 48, 64, button lit white. Double tap to access page ranges 80, 96, 112, 128, button is lit blue. While playing, only the actively playing page will be lit.



Steps are organised across a series of 8 pages covering the total 128 steps per sequencer presented as 16 steps for each page on the pad grid.

**F** If follower is active, the page viewed will automatically change to track the playhead position dynamically while playing. This can be toggled on or off by, Holding [Shift] + [Track]. When follower is active a 'F' is displayed in the upper display. It is useful to keep pages static while editing and when the sequencer is playing.

## 3 Sequencer Basics

### 3.3 Navigating the Sequencer & Step Parameters

The ONE sequencers have parameters that cover the steps, tracks and the sequencer itself. Some parameters control the global values, affecting say, all steps, while others focus on the individual function for example an individual step. These can be the same parameter but with a change in how it is applied.

In order to understand the overall parameter structure here is an introduction to navigating the available options. Some parameters and pages will be the same across sequencer modes while some are unique to the specific sequencer mode and will be detailed further in the mode description later.

#### Sequencer Setup.

Highest level of configuration for the overall sequencer including the configuration of its operating mode such as mono, poly, chord etc. Generally represents multiple pages of global sequencer settings including MIDI channel, output port, program / bank change, instrument definitions, color and more.



Open the sequencer setup. Hold [Shift] + tap [1] - [8]. These are mode dependant but in general consist of several pages of parameters. Once the menu is open, selection can be changed to another sequencer by pressing its button [1] - [8].



If additional parameter pages exist, the [Page] button will flash. Press [Page] to cycle through available pages. Also use [Shift] + sequencer button to cycle its pages.

Examples: Mono Mode

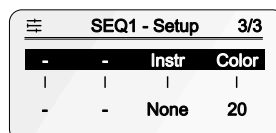
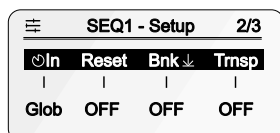
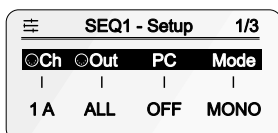

#### Track Setup.

General track oriented settings including playback direction, time division and navigation through viewing the grid octave range. Most modes have one track but for modes such as multi the track menu is important to manage the parameters for each of the 8 tracks.



Open the track setup. Tap [Track] button.

Example: Mono Mode

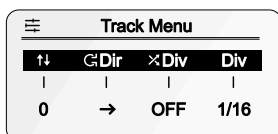

Parameters are edited with the respective knob. Some parameters will need to be confirmed by pressing the knob, once editing is complete. These are shown with the down arrow. Parameters that have been edited but the change has not been confirmed as active will be shown with a \* symbol.

## Step Setup.

Step setup typically falls into two sections. Firstly the global settings, applicable to all steps. Secondly the submenu options which apply to individual steps. Some generative modes are not edited on a step by step basis so there may be no step values visible.



**Step Global.** Access to global step, extended parameters for the selected sequencer, tap [Step] button.

Example: Mono Mode - Global

Step/Accml Global			
Rept	Durat	. . .	H +
...	...	...	...
Offst	AcmM	-	-
...	Step		



Within the displays that have a dual parameter row, tap the respective parameter knob to switch between the upper and lower parameter for editing.



**Step Primary Parameters & Step Submenu.** Access to the individual parameters only for the selected step, hold [Step] button.



**Multistep editing.** In some cases multiple steps can be held and edited together. The 'Multipress' header text will be displayed while editing multiple steps.



Cycle through the step primary and step submenu pages for the individual step selected, hold [Step] + tap [Page] button.

The global options for primary parameters are found in the main sequencer view as the default parameters, controlled by knob 1-4. Secondary options, tempo, swing, scale and root are accessible by holding shift button.

Example: Mono Mode - per Step

Stp 2				∩ D2	1/3
Vel	Oct	Gate	Trig		
75	+0	50	100%		

Stp 2				Submenu		2/3
Rept	Durat	. . .	H +			
No	x 1	±0%	±0%			
Offst	CVGld	∩Rng	Rpt%			
0%	0%	0st	100%			

Stp 2				Accum		3/3
Amt	Mode	Acml+	Acml-			
+0st	Wrap	+7st	-0st			
Total	Trig	%Mde	Acm%			
+0st	All	Iqnor	100%			

The display header carries useful information such as the note, octave, step etc. Corner tagged parameters indicate a value that can be modulated.

Some parameters can be reset to default. To reset a parameter back to its default setting, press and hold the respective knob for >2 seconds while holding the pad.

## 3 Sequencer Basics

### 3.4 Transport Controls

Transport refers to the three play, stop and record controls. Be aware that these can be operated manually on the panel or may be influenced by external control, for example an external clock. The descriptions here are based on internal synchronization.

#### Play Button



Stopped  
Grey



Playing  
Flash green / white

To play the sequencers, press [Play]. The sequencers will start playing typically from the first step in the pattern unless configured differently. The play button behavior can be reconfigured in the config > performance menu.

Play / Pause Button Behavior		
Access settings by [Shift] + [Config] > Performance		
Setting	Command	Description
OFF - Default	Play	Button will start playback from the first step. Any other press of play is ignored. Button flashes white and green
PAUSE	Play / Pause	Button will start playback. Another press of play will pause playback or restart playback from the paused position. Button flashes green while paused.
RESET	Play / Reset	Button will start playback. Another press of the play button will reset playback of the running sequencers to the start position once the punch-in quantization interval is achieved. Punch in quantization is labelled as 'In' on page 2/3 of the sequencer setup pages.

Recording options are based on capturing incoming MIDI data into the sequencers or for selecting step recording on the grid. The process of recording is explained elsewhere and in this section the basic commands are covered

#### Record Button



Not Recording  
Grey



Recording  
Red

**Record.** Press [Rec] to activate recording. This is used to record MIDI input or keyboard view data. Press again to exit recording.



Step Recording  
Flash red

+



Step Recording  
Grey

**Step Recording.** To enter or exit step recording, hold [Rec] + press [Play]. The step recording utility will be displayed which offers recording control using the knobs.



Arm Recording  
Turquoise

+



Arm Recording  
Grey

**Arm Recording.** To arm or disarm recording, hold [Rec] + press [Stop]. Arms recording pending a note input. Recording will start when a note is received.



+



**Recording Settings.** To enter or exit the recording settings, hold [Shift] + press [Rec]. Also press [Back] to exit the page.

#### — Note —

The playback 'reset' option controls all sequencers. However, to reset individual sequencers, hold [Shift] + [Mute] + Sequencer [1] - [8] for the sequencer to reset. The reset behavior relies on the punch-in quantization.

The stop button will not only stop the sequencer but can also control the sequencer reset or synchronization. The internal clock has a 96 PPQN resolution.

## Stop Button



Playing / Stopped  
Grey

To stop the sequencers, press [Stop]. The sequencers playhead will reset to the first step. When play is pressed it will start from this position.

Double tap to clear all MIDI, for example if there are hanging notes.



+



Playing  
Grey

To reset the sequencers while playing, hold [Shift] + press [Stop]. This follows the same punch-in quantization behavior as described above for the play button, although the play button configuration setting is not relevant here.

**Clock Synchronization.** With the sequencer stopped, the global clock synchronization can be changed. Hold [Shift] + tap [Stop] to cycle through the options of INT - Internal clock sync and external input options of USB, MIDI Jack or Bluetooth or Clock input. The current setting is displayed and the last selected mode is the default when **ONE** is powered up.

The sequencer will display the status of the playback with the transport buttons but also with the white play head cursor. This will show the current steps played as it travels in the playback direction. Given that the pattern may extend beyond the 16 step default, follower option can be selected. This will automatically follow the playhead across each page.

## Follower Option



+



Toggle follow function on or off by Holding [Shift] + tap [Track]. When on the grid pages will change to follow the playhead. When off the pages will remain static, as selected. This is useful if editing on the fly. Display will show a 'F' symbol in the display header when on.

---

### Note

When **ONE** is not set as the primary controller and with enabled in the config > MIDI settings, pressing the Play, Stop and Record buttons can output a MIDI CC message on port A. These are Stop = CC 105, Play = CC 106 and Rec = CC 107.

---

## 3 Sequencer Basics

### 3.5 Mute and Activation Behavior

The sequencer can be active, inactive, muted or unmuted. The behaviour of the mute button for this purpose can be configured in the settings. An active / inactive sequencer refers to the entire sequencer transport. When inactive, transport will be stopped, no steps triggered and hence is also muted as there is no output. Only an active, unmuted sequencer will issue control and note signals over the MIDI channel and physical outputs. Muting an active sequencer will still allow transport control but no control signals or notes are sent to the physical outputs. Also check settings for other muting configurations.



X 2

The [Mute] button is used to control muting and activation of sequencers. This is usually held along with the sequencer, step or track pads, however the mute button can be latched. Double tap [Mute] to latch the mute button on or to unlatch it off. Any subsequent commands while latched on, i.e. Tapping Seq [1] - [8] will operate as if the mute button is held.

#### Sequencer Activate / Mute Control Options

The mute behavior can be changed in the [Config > Performance > Mute Behavior](#) setting.

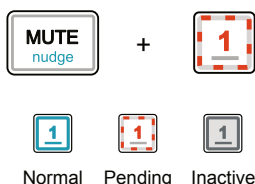

##### Toggle on Release (Default Config)

*Activate / Deactivate*

Hold [Mute] + Tap [1] - [8]. To activate or deactivate one or more of the sequencers. The action takes place only when the [Mute] button is released. While holding [Mute], the sequencers continue as normal, button flashes red to signify a pending deactivation. Transport playhead is then stopped. To reactivate mute will flash green pending activation. Transport restarts based on punch-in quantization.

Default

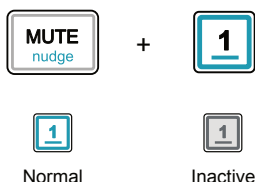

##### Toggle Instant (Config Option)

*Activate / Deactivate*

Hold [Mute] + Tap [1] - [8]. To activate or deactivate one or more of the sequencers. Transport playhead is stopped. Muting / unmuting is applied immediately when pressing this button combination. When unmuted, transport restarts based on punch-in quantization.

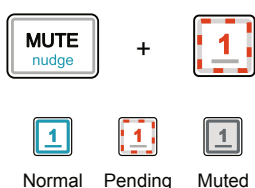

##### Mute on Release (Config Option)

*Mute / Unmute*

Hold [Mute] + Tap [1] - [8]. To mute or unmute one or more of the sequencers. Transport playhead keeps running. Muting / unmuting takes place only when the [Mute] button is released. While holding [Mute], the sequencers continue as normal, button flashes red to signify a pending mute command and will flash green pending an unmute command. Sequencers are still active, but all physical outputs are silenced.

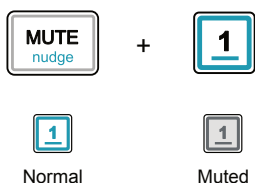

##### Mute Instant (Config Option)

*Mute / Unmute*

Hold [Mute] + Tap [1] - [8]. To mute or unmute one or more of the sequencers. Transport playhead keeps running. Muting / unmuting is applied immediately when pressing this button combination. Sequencers are still active, but all physical outputs are silenced.

#### Alternative Mute Sequencer & Mute Track Options (Default)



Hold [Mute] + Tap any [Pad] in column 1 of the 16 x 8 grid. Transport playhead continues as normal. This is an alternate way to mute and unmute a sequencer especially useful in multitrack mode where each track row can be muted / unmuted. This command is applied immediately when pressing this button combination and does not adhere to the mute behavior described above.

## 3.6 Sequencing Steps

In most modes the programming of steps in a sequencer is performed by using the 16 x 8 grid pads. In some modes and views the pads may also be used for applying parameter changes, however here we explain the general process of programming steps on the grid. Note that the color scheme in view will depend on the sequencer selected. Ensure the desired sequencer is selected for editing.

### Creating Steps

**Activate or deactivate a step.**  
Quickly tap [Pad]. (1)



Grid represents 16 columns of steps and 8 rows of notes.  
The view can be navigated by the page buttons and scrolling the octave ranges.

**Tie multiple steps, same row.**  
Hold 1<sup>st</sup> [Pad] + tap last [Pad].

Ties all steps between the two pads (2).

Pads must be pressed in the order stated.

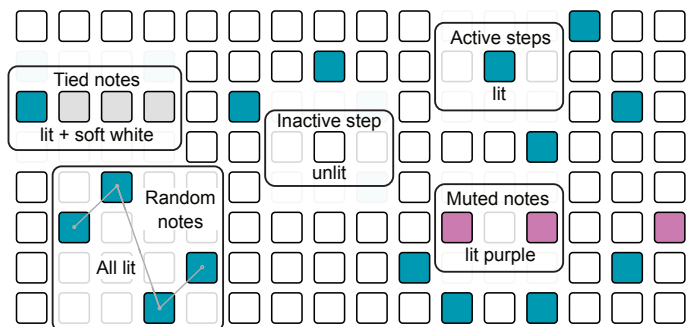
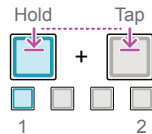

**Reverse tie, same row.**

Hold last [Pad] + tap 1<sup>st</sup> [Pad]. (3)

Random or fill sequence across the pads.

Pads must be pressed in the order stated.

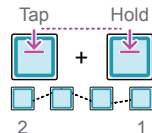

Reverse ties can be set to Off, Random or fill. (3)

(1) When a step is deactivated the parameters that have been applied will be cleared. This is default behavior. This can be changed in the config > workflow settings to remember the parameter changes for a step when deactivated and to restore them back if the step is reactivated later. This is useful for preparing steps before making them active, especially when performing live.

(2) Steps can also be tied across pages. To tie steps, keep hold [Pad] on the first page, press the [Page] for the end location. While still holding the first step, press [Pad] for the end of the tie on the new page. Ties must be made on the same row and octave. The tie setting is also available in the gate parameter values. When setting a tie using grid pads, ensure the pads are held / tapped in the correct sequential order as stated in the command. Tapping a pad within a tie will split the tie and create a new step.

(3) When applying the reverse tie, ie. Last + first pad, the steps will be populated between the two pads. The behavior of these steps is configured in the Config > Workflow > Inverted TIE gesture Fills or Random setting. If set to 'Random', notes are populated as random values. If set to 'Fill' the equivalent note value is populated as a fill in each step. This option can also be set to 'Off'.

### Editing Step Parameters

**Edit an active step's parameters.**  
Hold active [Pad] + turn (Knob).



Parameters are displayed in the home sequencer view (4).  
Includes; velocity, octave, gate & trig, edited with knobs 1-4.

**Edit an inactive step's parameters.**  
Hold inactive [Pad] + turn (Knob).



To change parameters before making a step active.  
Used when config is set to not remove parameters when clearing steps. (1)

Hold [Pad] + [Page].

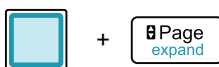

Access to an additional set of sub-menu and more advanced parameters. Also access using [Shift] + [Pad].

(4) Steps placed on the grid will adopt the current global parameter settings. Any edits to the global parameters will be automatically applied to all existing steps, the change applied is relative to its original value and the range of values will be displayed. Steps can be edited individually by holding the step and adjusting the knob for the specific value.

## 3 Sequencer Basics

### 3.7 Global Sequencer View Parameters

In sequencer view, a set of generic parameters that can be edited directly with the rotary encoder knobs. In addition the grid column pads can be used as a parameter editor for each option that is selected. The primary parameters can be adjusted globally for all steps or some can be edited at an individual step level when holding a step pad. Secondary parameters mainly focus on global or sequencer settings.

The primary global setting will:-

- Set the parameter value when subsequently laying down individual steps.
- Adjust the value of any existing step values relative to their current value. If this is a multitrack, then all steps on the selected track are affected. Individual step values can also be edited separately. Some other views and sequencer modes may change the default functions of these controls.

#### Global Controls

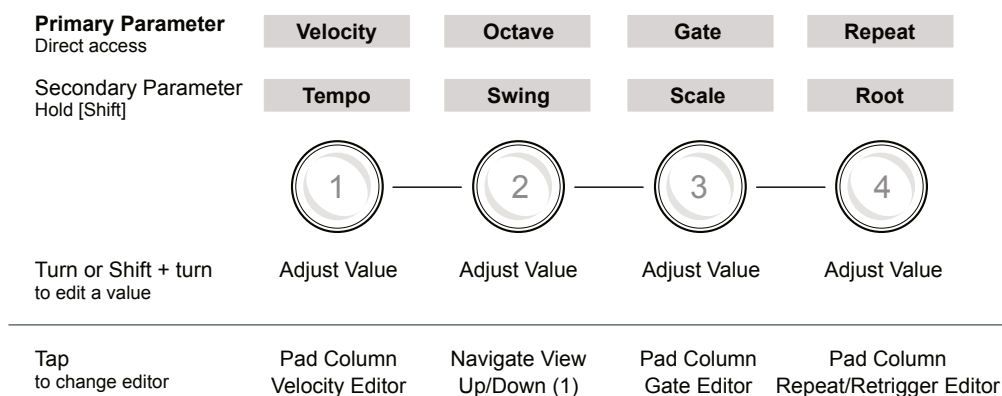

(1) In a multitrack sequencer, tapping the octave knob will open the pitch editor.

#### Octave Parameter

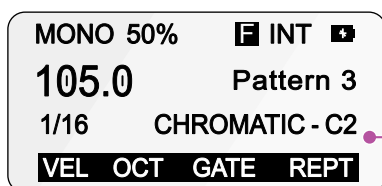

The octave can be adjusted using the [Oct] knob. This is the base octave on the grid for the selected sequencer and ranges from -2 to +7 based on the root selected. Edit root by holding shift and turning knob 4, (Root). The octave value of each step will be offset from this base octave.

Range is Root -2 to Root +7  
e.g. C-2 to C7

#### Velocity, Gate & Repeats Parameters

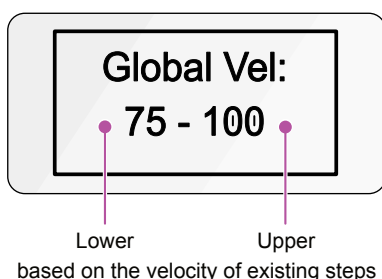

Lower Upper  
based on the velocity of existing steps

The global values for velocity, gate and repeats are shown as a lower and upper range if multiple steps are selected with different values for editing. The values are based on the lowest and highest value from the steps already placed on the grid. If no steps exist, the default is used. When editing these global values the existing step values will change relative to the adjustment made. The value range will compress when adjusting at the upper and lower limits, also reflected in each step value. For example, the velocity upper limit is 127 and all steps will change to this value if editing the global velocity to the maximum level.

Sequencer View Parameters				
Parameter	Label	Command	Range	Description
Velocity	VEL	(Knob 1)	1 - 127 Default 75	Controls the trig envelope amplitude for the output affecting the CV level. Global velocity sets a lower - upper range based on existing step values to allow relative changes. Hold a step pad to edit the individual step value. Tap for the step velocity grid column view to edit the active velocity using the grid column pads for each step.
Octave	OCT	(Knob 2)	-C2 to +C7 Default C2	The global octave assigns a base octave range (not the note) for the sequencer grid notes. Individual step value can also be set as a octave value offset up or down from this global base octave. Tap to toggle the knob to control scroll navigation up/down the grid or to reset back to the default view.
Gate	GATE	(Knob 3)	2 - 99, Tie or Legato Default 50%	Sets the duration of the note with respect to the sequencer note division using the envelope decay time. The global option is set as lower - upper percentage range based on any existing step values in order to allow relative changes. Example, a 50% value for a note in a 1/16th division pattern will last for half the time division, giving a 1/32 note length. Tap for step gate view and to edit the active step gate value using the grid column interface. Hold a step pad to edit an individual step. Also applies a tie or legato setting.
Repeat	REPT	(Knob 4)	1 - 15 Default 1	Turn to adjust the lower - upper values for the repeat option. This will activate a selected number of repeats at the note interval. This can be set between 1-15 repeats. The grid pad column view also gives access to the retrigger option. Retrigger can activate between 1-8 ratchets within the note duration.
Tempo	BPM	[Shift] + (Knob 1)	20 - 300 Default 80	Sets the global beats per minute for all sequencers. This is used as the internal clock but internal tempo is not used if an external clock is selected. Tap tempo can also be applied.
Swing	SWNG	[Shift] + (Knob 2)	10 - 90 Default 50	Swing introduces a more natural and slightly off grid feel to bring interest to the rhythmic groove of a sequence. Increasing swing above 50 will push some notes slightly late and lowering the swing below 50 pulls some notes slightly early. Default of 50 means no swing is applied. Each sequencer can have its own unique swing setting.
Scale	SCAL	[Shift] + (Knob 3)	Options Default Chromatic	Selects a scale for the sequencer. A library is available from which to choose. The behavior of the scale function is also dependant on the scale quantization setting.
Root	ROOT	[Shift] + (Knob 4)	C-2 to B7 Default C2	Selects a root note for the sequencer. This is typically represented by the bottom row of the grid in most modes.

— Note —

The defaults for the velocity and gate setting are 75 and 50 respectively. These can be changed in the config > workflow options.

# 3 Sequencer Basics

## 3.8 Velocity

Velocity represents how hard an instrument's note is played. Think of the effort applied when playing piano keys. Velocity is therefore considered modulation, and when sequencing, notes can be set to a global value or step value between 1-127. This can be applied to a destination instrument for example with MIDI to a synth or out to CV.

Velocity can be edited globally using the encoder knob 1 or set on a per step basis. The grid pad column editor can also be used to modulate the velocity values. Global velocity is default when turning to edit. For step velocity, hold a step and turn velocity. Tap the knob to open the respective pad column editor. Velocity affects the amplitude of the attack / decay output envelope. Velocity lanes are independent meaning the start and end points can be set differently between velocity and the note lane.

### Global Velocity Editing

Changing global velocity will alter the range dynamically across all existing pads relatively or set a value that will be used for placing subsequent steps where the lower velocity value in the range is used.

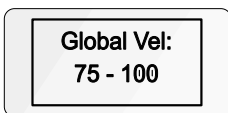

Turn knob 1 (Vel).

### Step Velocity Editing

Placing new steps will apply the current lower global value for the step velocity. Any changes to the global velocity will adjust all of the existing steps relatively. Editing the velocity for individual steps is also possible while holding the chosen step.

Stp 2	J D2	1/3	
Vel	Oct	Gate	Trig
75	+0	50	100%



Hold step [Pad] + turn knob 1 (Vel).

Note that holding step and tapping knob 1 (Vel) will also mute or unmute the selected step.

### Grid Column Velocity Editor

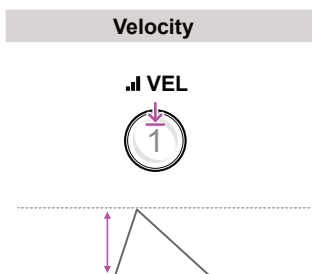

Affects the output envelope amplitude

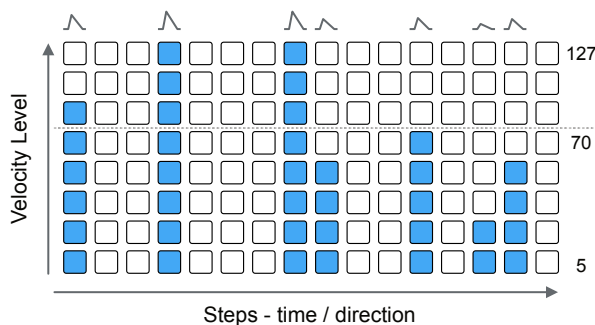

**Open the grid column editor:** Tap knob 1 (Vel). To temporarily view the editor, Hold knob 1 (Vel).

Tap a pad up or down the column to adjust the respective step's velocity level. Tapping an empty column, i.e. no step, will add a step at the velocity level selected. Steps can also be removed by tapping the bottom column pad to remove the step.

## 3.9 Gate

Gate represents the duration that a note is played, controlled on a step basis or extending across multiple steps by tying a series of steps on the same row together. Legato creates a glide between steps. When sequencing, gate can be set to a global value or step value between 2-99. Consider the destination envelopes too.

Gate can be edited globally using the encoder knob 3 or set on a per step basis. The grid pad column editor can also be used to change the gate modulation values. Global gate is default, hold a step and turn for step gate and tap the knob to open the respective pad column editor. Gate affects the decay of the attack / decay output envelope. Gate lanes are independent meaning the start and end points can be set differently between velocity and the note lane.

### Global Gate Editing

Changing global gate will alter the range dynamically across all existing pads relatively or set a value that will be used for placing subsequent steps where the lower value in the gate range is used.

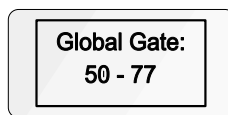

Turn knob 3 (Gate) slowly.

Turn knob 3 (Gate) quickly clockwise to set a tie.

Turn knob 3 (Gate) quickly counter-clockwise to break tie.

### Step Gate Editing

Placing new steps will apply the current lower global value for the step gate. Any changes to the global gate will adjust all of the existing steps relatively. Editing the velocity for individual steps is also possible while holding the chosen step. As well as a gate length and tie, a note can be set to LEG - Legato to create a seamless pitch glide between sequential notes.

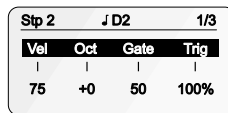

Hold step [Pad] + turn knob 3 (Gate) slowly.

[Pad] + Turn knob 3 (Gate) quickly clockwise to set a tie.

[Pad] + Turn knob 3 (Gate) quickly counter-clockwise to break tie.

### Grid Column Velocity Editor

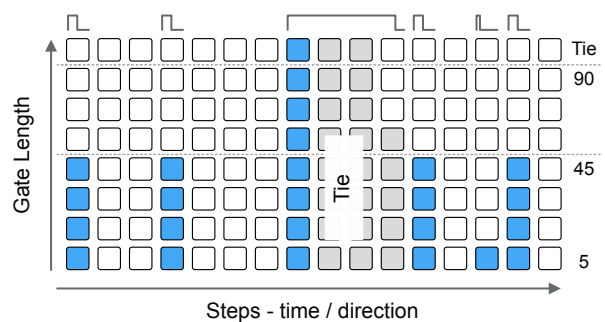
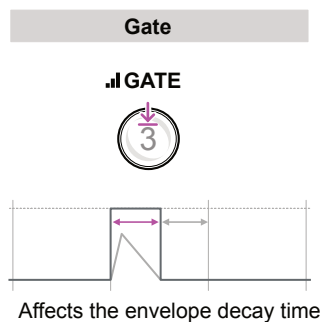

**Open the grid column editor:** Tap knob 3 (Gate). To temporarily view the editor, Hold knob 3 (Gate).

Tap up or down the column to adjust the respective step's gate length. Tapping an empty column will add a step at the gate level selected. Steps can also be removed by tapping the bottom column pad to remove the step. Tap a top row pad to select a tied step, the following columns set the tie duration.

# 3 Sequencer Basics



## 3.10 Repeat & Retrigger

The repeating of triggers during playback is a creative behavior option that can be applied in ONE and is controlled in two ways. Repeat can be set at a global and step level. This will replicate the playback of a triggered note at a defined number of iterations across a step duration. Assigning the 'skip' option to an individual step will ignore the step timing, shortening the sequence.

Retrigger is a variation on the repeat behavior typically controlled at global level to create a ratcheting effect over a step interval. Retriggerers can be transitioned to repeats in the extended step menu.





### Global Repeat & Retrigger Editing

Direct adjustment of the repeat knob 4 will affect the number of repeats across all steps. Tapping knob 4 will switch to the retrigger / repeat grid column editor. Turning knob 4 directly affects repeats. A setting of 1 means no retrigger or repeats, just playback of the single original step.

<b>Glob Repeat:</b> 4 - 15		Turn knob 4 (Rept). In <u>sequencer view</u> , affects global repeats 1-15.
.  RETRIG (Shft) REPEAT		<b>Open the grid column editor:</b> Tap knob 4 (Rept). Hold knob 4 (Rept) to temporarily view the editor.
<b>Global Retrig:</b> 8 - 8		Turn knob 4 (Rept). In the repeat <u>grid column editor</u> view, affects global retriggerers 1-8.

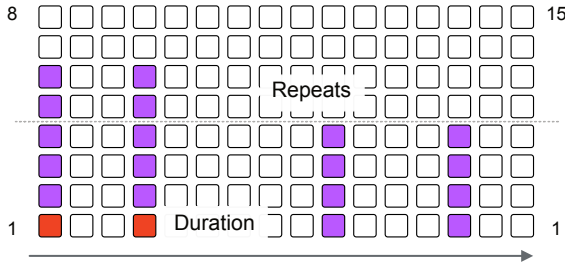
### Grid Column Repeat Editor

In the pad column editor, turn (Rept) Knob 4 to adjust the retrigger's or alternatively tap up or down the column to adjust the respective step's retrigger. To adjust the repeats in the column editor view, hold [Shift] while adjusting Knob 4 or by tapping a column [Pad] for repeats and [Shift] + [Pad] for repeat duration indicated by red pads. The repeat modulation lanes are independent to the note lane.

<b>Retrigger</b>	Both retrigger and repeats are displayed on the grid	<b>Repeat</b>	<b>Repeat Duration</b>
		 + 	 + 

**Retrigger example**  
Time divisions e.g. 1/16<sup>th</sup>



original note  
 retriggered note

4 retriggerers

**Repeat example**  
Time divisions e.g. 1/16<sup>th</sup>



original note  
 repeated note

4 repeats

When working with individual steps a set of extended options exist which include more precise step repeat control. This submenu can be found by holding the [Pad] + tapping [Page] to cycle through the extended page options.

## Step Specific Repeat Control

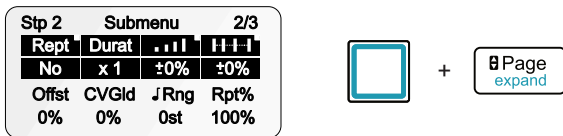

Tap the respective knob to switch between editing the upper and lower parameters. Keep [Pad] held to edit the parameters using the four knobs.

Step Repeat Parameters			
Rept	Durat	Ramp ■■■■	Acceleration ■■■■
Repeats for the step	Step Duration	Repeat velocity ramp	Repeat acceleration
Set the number of step notes in order to create repeats. Set to 'Off' or to a defined number of repeats 2-15 or to skip the step.	Sets the number of steps that the repeat is extended over.	Applies a ramp up 0 to +70% or ramp down 0 to -70% of the velocity across the repeats.	Applies acceleration 0 to +28% or deceleration 0 to -28% of the the repeat timing.
Offst	CVGld	Rng	Rpt%
Timing Offset	CV Glide	Randomized Note Range	Repeat probability
Note timing offset -45% to +45%, based on the time division of the grid.	Sets glide amount between repeats to introduce a smooth note transition. Only used for CV as MIDI doesn't support.	Sends a random note with pitch variation. The note generated is within the active, +/-24 to 0 to +24 scale interval range *.	Probability and logic conditions which activate repeat notes events or not.

\* While the range is generally stated as 'st', semitones, the actual interval is based on the relationship between notes in the currently active scale. The +/- 24 therefore is a note interval between notes in the scale and not strictly semitones

### 3 Sequencer Basics

#### Repeats & Duration

The 'Rept' parameter sets the amount of repeats that will be applied in the step period. This starts at a maximum of 8 at x1 duration but expands up to 15 when the duration value is increased. The length of the repeat chain can be extended over a duration covering multiple steps. This is set using the 'Durat' parameter with options ranging from x1 to x15 steps.

Examples

■ original note    ■ repeated note    1/16<sup>th</sup> notes

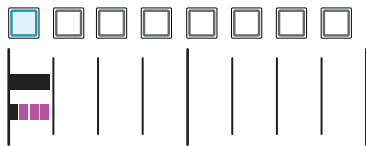

**Repeats.** The starting point would be a set number of repeats, say 4 that cover the x1 step duration.

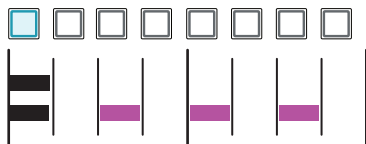

**Duration.** The same retrigger count can be adjusted using a duration covering a longer step length. Example shows 4 retriggers and x8 duration.

#### Velocity Ramp, Acceleration and Probability

The option to change the repeat behavior is also possible by ramping up or down the velocity of the repeats, set over a +/-70% range. Here less is more, so try smaller values first. In addition the repeat intervals can be accelerated or decelerated from the initial step and over a +/-28 range.

Examples

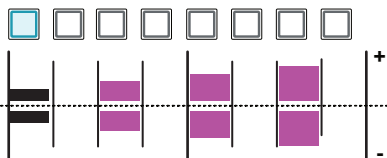

**Ramp.** The starting point would be a set number of repeats, say 4 that cover the x8 step duration. The Y axis in this example refers to velocity level and this sets the ramp amount.

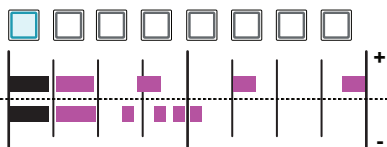

**Acceleration.** The same repeat count can be adjusted using duration over a longer step length. Example shows 6 repeats and x8 duration.

**Probability % & Logic Conditions.** A trigger condition parameter can also be set which determines if and when a repeat action is activated along with the step trigger, or not.

## 3.11 Trigger Probability

Trigger probability, labelled 'Trig' in the step parameters, is only available at a per step level. Holding one or more steps will allow the trig parameter to be edited using knob 4 for these steps. One trig condition is set per step. Trig value is evaluated on each cycle of the sequencer, commencing from pressing play and then sets whether the step will be triggered or not. The same model is applied for the repeats engine and any other probability functions.

Stp 2	J D2	1/3	
Vel	Oct	Gate	Trig
75	+0	50	100%

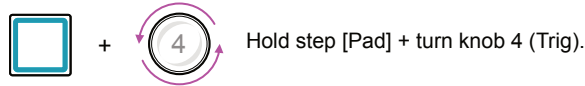

Reset the trig value to either 100% or Fixed lock



Knob 4 will set the global repeat by default and revert to step triggers while holding one or more steps.

### Probability %

Trig can be assigned a probability % value which sets how likely it is for a step to trigger or not. Default is 100% meaning a step will trigger on each sequence cycle as normal and 0% will never trigger. Anything in-between will trigger in a random style frequency based on the %. For example, 50% doesn't trigger predictably, once every other cycle, but generally it will trigger 50% of the time on average.

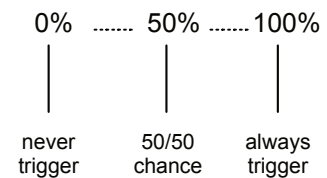

### A:B Logic Condition

The logical options offer a predictable application variation into a pattern when triggering notes on sequencer count cycles. The A represents the number of the cycle that will trigger the step. The count is reset after sequencer completes cycle number B.

Options: 1:2, 2:2, 1:3, 2:3, 3:3, 1:4, 2:4, 3:4, 4:4, 1:5, 2:5, 3:5, 4:5, 5:5, 1:6, 2:6, 3:6, 4:6, 5:6, 6:6, 1:7, 2:7, 3:7, 4:7, 5:7, 6:7, 7:7, 1:8, 2:8, 3:8, 4:8, 5:8, 6:8, 7:8, 8:8

Examples:



#### Example: 2:4

Trigger on the 2<sup>nd</sup> cycle of a 4 count. Reset at the end of 4<sup>th</sup> cycle. The pattern will trigger overall on every 2<sup>nd</sup>, 6<sup>th</sup>, 10<sup>th</sup> and so forth.

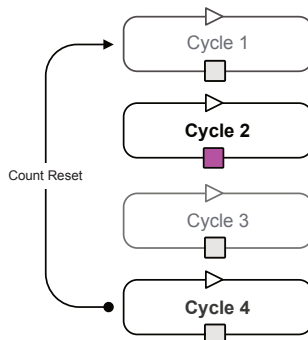

#### 1:2

Trigger is active on first loop, not the second. The count resets after the second loop and this on/off trigger cycle pattern continues.



#### 3:4

Trigger is active on third loop and the count resets after the fourth. The pattern will trigger overall on every 3<sup>rd</sup>, 7<sup>th</sup>, 11<sup>th</sup> etc.



# 3 Sequencer Basics

## A:B Logic Condition

Similar principles as the A:B model but follows a logical 'not' condition. The A represents the number of the cycle that will NOT trigger the step. All other cycles will trigger the step. The count is reset after sequencer completes cycle number B.

Options:  $\overline{1:2}$ ,  $\overline{2:2}$ ,  $\overline{1:3}$ ,  $\overline{2:3}$ ,  $\overline{3:3}$ ,  $\overline{1:4}$ ,  $\overline{2:4}$ ,  $\overline{3:4}$ ,  $\overline{4:4}$ ,  $\overline{1:5}$ ,  $\overline{2:5}$ ,  $\overline{3:5}$ ,  $\overline{4:5}$ ,  $\overline{5:5}$ ,  $\overline{1:6}$ ,  $\overline{2:6}$ ,  $\overline{3:6}$ ,  $\overline{4:6}$ ,  $\overline{5:6}$ ,  $\overline{6:6}$ ,  $\overline{1:7}$ ,  $\overline{2:7}$ ,  $\overline{3:7}$ ,  $\overline{4:7}$ ,  $\overline{5:7}$ ,  $\overline{6:7}$ ,  $\overline{7:7}$ ,  $\overline{1:8}$ ,  $\overline{2:8}$ ,  $\overline{3:8}$ ,  $\overline{4:8}$ ,  $\overline{5:8}$ ,  $\overline{6:8}$ ,  $\overline{7:8}$ ,  $\overline{8:8}$

Examples:

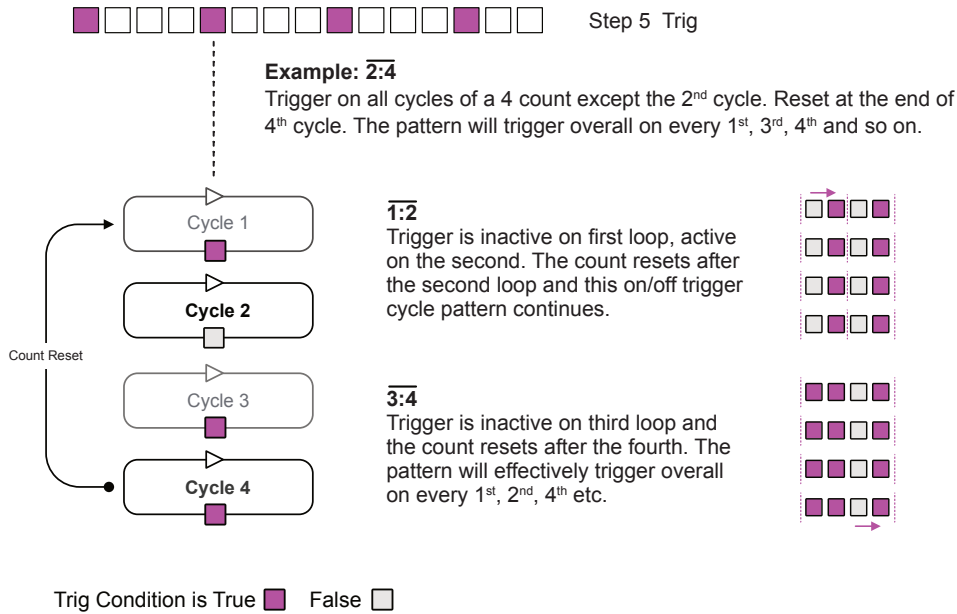

## PRE / $\overline{\text{PRE}}$ Logic Condition

PRE activates this trig on the chosen step only when the nearest prior step condition is true. This check refers to the previous, most recent trigger condition state and is not based purely on whether the prior step itself is active or not but it depends on its trigger state. This step will not trigger if the prior trigger condition is not met i.e. 'false'. If set to 'Not Pre' i.e.  $\overline{\text{PRE}}$ , the step will trigger if the prior trigger condition is 'false'.

Examples:

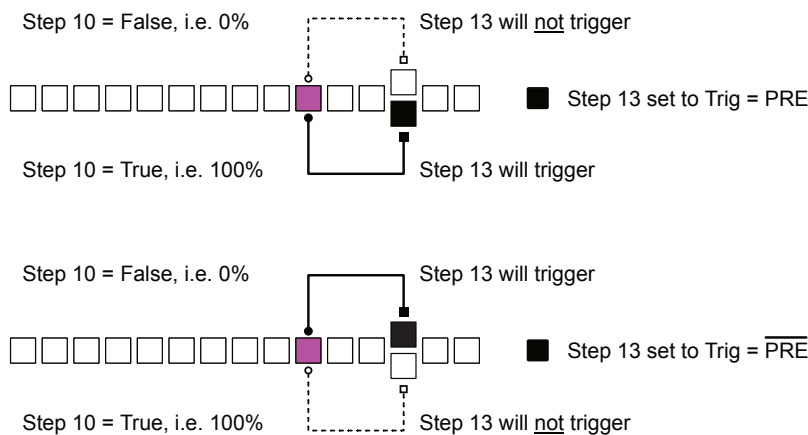

## 1st / $\overline{1st}$ Logic Condition

1st activates this trigger on the chosen step only on the first sequencer cycle. This step will not trigger the step when playing subsequent consecutive sequencer cycles. If set to 'Not 1st' i.e.  $\overline{1st}$ , the step will trigger on all cycles of the sequencer other than the first cycle where it does not trigger.

Examples:

Steps 14 and 16 will only trigger on the first sequencer cycle then not trigger further.

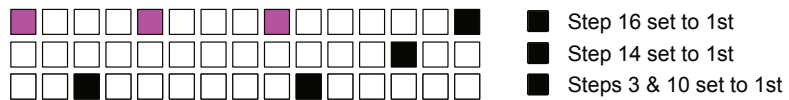

Steps 3 and 10 will not trigger on the first sequencer cycle but will trigger further on future cycles.

## Fixed Logic Condition

When set to 'Fixed', the step is always triggered but cannot be modulated or affected by a randomization sources such as Euclidean and random generators. The normal behavior will typically be similar to a 100% probability. Hold [Pad] step + Hold Knob 4 (Trig) to toggle between 100% probability and fixed settings.

## Locked Logic Condition

When set to 'Locked', the step is always triggered but cannot be modulated or affected at all. Sources including Euclidean and random generators do not affect a locked step. The normal behavior will typically be similar to a 100% probability. A lock symbol will be shown in the step display header.

## Flow / $\overline{Flow}$ Logic Condition

ONE has a dedicated [Flow] button which is used to allow triggering of various actions including selected notes, passages and fills. The basic principle is that any step with the trig parameter set to FLOW will only play in its sequenced order, while the flow button is held. Otherwise the steps will not trigger if the flow button is released. In contrast, when set to 'No Flow'  $\overline{Flow}$ , the steps will play as normally unless the flow button is held, in which case these steps remain silent during the sequence.

Examples:

Steps assigned with a flow condition will only apply the condition while holding [Flow].

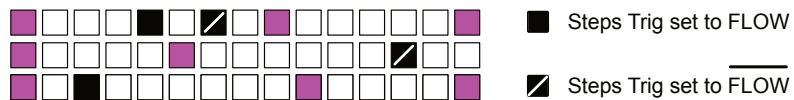

Hold [FLOW] to trigger these steps as the sequencer plays ■  
 Hold [FLOW] to silence these steps as the sequencer plays ▨

—Note—







Building patterns with logical conditions can create interesting an almost generative style patterns, especially when combining the logical conditions across multiple steps in a sequence.

## 3 Sequencer Basics

### 3.12 Tempo





Tempo is a global function which sets the speed of playback for all sequencers collectively and is found in the sequencer view secondary parameters. This is set in beats per minute ranging from 20 BPM up to 300 BPM. The default is 80 BPM. Tempo is only used and accessible for internal clock synchronisation and is ignored if an external sync is selected.

#### Tempo BPM

- |   |   |   |  |
|---|---|---|--|
|  | + |  | To adjust the tempo, hold [Shift] + turn knob 1 (BPM). This will set the global tempo in beats per minute. This value is shown prominently on the display. Adjust quickly for large increments and slowly for smaller, point increments. |
|  | + |  | To reset the tempo, hold [Shift] + tap knob 1 (BPM). This will reset the global tempo in beats per minute to the default 80BPM.  |
|  | + |  | To tap a tempo value, hold [Shift] + tap [Play] several times. The number of taps to average is selectable in the config > performance menu.   |

Tempo can be adjusted while playing, but cannot be reset while playing.

#### Tempo Nudge

- |   |   |   |   |
|---|---|---|---|
|  | + |  | To nudge the tempo up in beats per minute, hold [Mute] + hold [Play]. The tempo will increase while the button combo is held. Release the buttons to immediately revert to the original BPM tempo.  |
|  | + |  | To nudge the tempo down in beats per minute, hold [Mute] + hold [Rec]. The tempo will decrease while the button combo is held. Release the buttons to immediately revert to the original BPM tempo. |

Nudging the tempo is useful for beat matching when DJ mixing or when synchronising to other instruments.

Tempo is saved with the project. A project can be loaded during playback and as such the tempo will be applied from the loaded version. This may differ from the current tempo. There are two key options to consider for tempo when working with multiple projects:-

- **Load Project BPM update during playback.** Located in the config > performance options this can be set to 'Yes' or 'No'. If set to 'Yes' the BPM will change automatically for the playing project immediately upon loading the new project.
- **Global Launch Quantization.** Defines the behaviour of various functions during a launch state including project launch. Determines when a new project will load after it is selected during playback of the current project. This is set in the launch settings of the arranger page and can be set to the number of bars for a pattern cycle before the new project is launched.

---

#### Note

Tempo is a global parameter than can be modulated from an external MIDI CC controller. This is setup in the OXI **ONE** using the MIDI mappings configuration found in the 'ext mod' options accessed with [Shift] + [Mod], and by using the 'PARA' option.

---

## 3.13 Swing

Swing is a function which slightly adjusts the notes of a pattern in order to introduce a more natural and subtle rhythmic feel into the notes of pattern. This adds a minor shuffle with a less mechanical and rigid style.

Swing can be adjusted per sequencer or per track and is set to a value between 10-90. The default value is 50 which represents no swing applied. Select the sequencer to edit before applying swing.

### Swing



+



To adjust the swing, hold [Shift] + turn knob 2 (Swng). This will set the swing for the selected sequencer between 10-50. This value is shown prominently on the display.



+



To reset swing, hold [Shift] + tap knob 2 (Swng). This will reset to the default value of 50 - no swing.

Swing  
Time divisions e.g. 1/16<sup>th</sup>

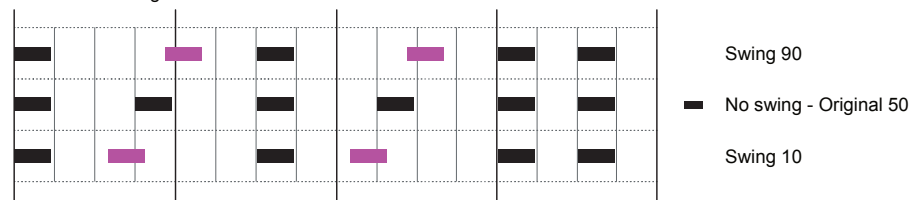

Swing behavior is also relative to time division and signature. As a general guide, swing will push some notes slightly back or ahead of the rigid grid.

- **Swing > 50.** Increasing the swing value will push some notes later in the time line of the grid giving a more lazy, relaxed feel and adds anticipation. Maximum is 90.
- **Swing < 50.** Decreasing the swing value will pull some notes earlier in the time line of the grid giving a more hurried, quicker feel and adds urgency. Minimum is 10.

## 3 Sequencer Basics

### 3.14 Scale and Root

The sequencer view grid rows typically represent notes in most of the sequencer modes and especially per track. The mono mode for example starts with note C2 on the bottom row up to G2 top row when set to the default scale of Chromatic C2. The scale and root note can be changed for each sequencer and presented on the grid. The currently selected scale is retained when changing sequencer modes.

Scale is selectable from an onboard library of scales or one of 16 user scales, created and loaded from the OXI App. Scale will also be used for scale quantization and the harmonizer function.

#### Scale



To select a scale, hold [Shift] + turn knob 3 (Scal). This will set the scale for the selected sequencer.

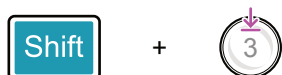

To reset scale to the default, hold [Shift] + tap knob 3 (Scal). This will reset to the default CHROMATIC scale.

If the config > workflow option - 'confirm scale change and quantize notes' is set to ON, you will need to press Knob 3 after editing the scale to confirm. In this mode, the scale will be shown with an asterisk '\*' if it has been changed but is unconfirmed, in which case the original scale remains active.

#### Root Note



To select a root, hold [Shift] + turn knob 4 (Root). This will set the root note for the selected sequencer.

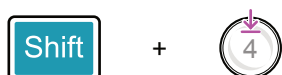

To reset root to the default, hold [Shift] + tap knob 4 (Root). This will reset to the default C2 note.

#### Examples:

Examples of grid layout based on the selected root and scale.

Chromatic, Root C2

G2	<input type="checkbox"/>	<input type="checkbox"/>	<input type="checkbox"/>
F#2	<input type="checkbox"/>	<input type="checkbox"/>	<input type="checkbox"/>
F2	<input type="checkbox"/>	<input type="checkbox"/>	<input type="checkbox"/>
E2	<input type="checkbox"/>	<input type="checkbox"/>	<input type="checkbox"/>
D#2	<input type="checkbox"/>	<input type="checkbox"/>	<input type="checkbox"/>
D2	<input type="checkbox"/>	<input type="checkbox"/>	<input type="checkbox"/>
C#2	<input type="checkbox"/>	<input type="checkbox"/>	<input type="checkbox"/>
<b>C2</b>	<input type="checkbox"/>	<input type="checkbox"/>	<input type="checkbox"/>
	c	d	e

Major, Root G3

G4	<input type="checkbox"/>	<input type="checkbox"/>	<input type="checkbox"/>
F#4	<input type="checkbox"/>	<input type="checkbox"/>	<input type="checkbox"/>
E4	<input type="checkbox"/>	<input type="checkbox"/>	<input type="checkbox"/>
D4	<input type="checkbox"/>	<input type="checkbox"/>	<input type="checkbox"/>
C4	<input type="checkbox"/>	<input type="checkbox"/>	<input type="checkbox"/>
B3	<input type="checkbox"/>	<input type="checkbox"/>	<input type="checkbox"/>
A3	<input type="checkbox"/>	<input type="checkbox"/>	<input type="checkbox"/>
<b>G3</b>	<input type="checkbox"/>	<input type="checkbox"/>	<input type="checkbox"/>
	c	d	e

Locrian, Root D1

D2	<input type="checkbox"/>	<input type="checkbox"/>	<input type="checkbox"/>
C2	<input type="checkbox"/>	<input type="checkbox"/>	<input type="checkbox"/>
A#1	<input type="checkbox"/>	<input type="checkbox"/>	<input type="checkbox"/>
G#1	<input type="checkbox"/>	<input type="checkbox"/>	<input type="checkbox"/>
G1	<input type="checkbox"/>	<input type="checkbox"/>	<input type="checkbox"/>
F1	<input type="checkbox"/>	<input type="checkbox"/>	<input type="checkbox"/>
D#1	<input type="checkbox"/>	<input type="checkbox"/>	<input type="checkbox"/>
<b>D1</b>	<input type="checkbox"/>	<input type="checkbox"/>	<input type="checkbox"/>
	c	d	e

— Note



The editing of the scale and root can be locked during playback which protects from accidentally changing the settings when performing with ONE. This is a setting found in the config > workflow options.



Scale Options			
Label	Scale	Label	Scale
HARMON	Harmonizer Option	PERSIAN	Persian
CHROMATIC	Chromatic	DIMINISH	Diminished
MAJOR	Major	PHRYGDOM	Phrygian Dominant
MINOR	Minor	BYZANTINE	Byzantine
DORIAN	Dorian	SpainPHRY	Spanish Phrygian
PHRYGIAN	Phrygian	NeapolMIN	Neapolitan Minor
LYDIAN	Lydian	NeapolMAJ	Neapolitan Minor
MIXOLYDIAN	Mixolydian	UKRANDORI	Ukranian Dorian
LOCRIAN	Locrian	USER 1	User Configurable
PENTAMAJ	Major Pentatonic	USER 2	User Configurable
PENTAMIN	Minor Pentatonic	USER 3	User Configurable
HARM MIN	Harmonic Minor	USER 4	User Configurable
MELODIC	Melodic Minor	USER 5	User Configurable
BLUES	Blues	USER 6	User Configurable
ARABIAN	Arabian	USER 7	User Configurable
ROMANIAN	Romanian	USER 8	User Configurable
BALINESE	Balinese	USER 9	User Configurable
HUNGAR 1	Hungarian 1	USER 10	User Configurable
HUNGAR 2	Hungarian 2	USER 11	User Configurable
ORIENTAL	Oriental	USER 12	User Configurable
RAGATOE	Raga Todi	USER 13	User Configurable
CHINESE	Chinese	USER 14	User Configurable
JAPAN 1	Japan 1	USER 15	User Configurable
JAPAN 2	Japan 2	USER 16	User Configurable

User scales can be created and loaded from the OXI App.

### Copying Scale & Root between sequencers

It is possible to copy the scale or root in the current sequencer and paste into another chosen sequencer using the copy and paste commands along with the respective knob.

 +  To copy a scale, hold [Copy] + tap knob 3 (Scal). This will copy the scale for the selected sequencer. This process can also be applied to knob 4 for the root.

 +  To paste a scale, hold [Paste] + tap knob 3 (Scal). This will copy the scale to another selected sequencer. This process can also be applied to knob 4 for the root.

# 3 Sequencer Basics

## Master Scale & Root.

One sequencer can be assigned as the master scale and root reference. All other sequencers will be automatically set to the global scale at the point of the global scale sequencer being assigned. Sequencers can be edited independently afterwards. Exceptions are multitracks in chromatic mode or sequencers set to harmonizer which will retain their original setting. The master sequencer is assigned in the project options.

Set the master sequencer in: Project > 'Scale Master Seq'.

## Scale Quantization

The way that scale operates in ONE is dependant on the scale quantization setting. One of two options can be set in the config > workflow which determines the scale behavior.

Set in: Config > workflow option: 'Confirm scale change and quantize notes'

Confirm scale change and quantize notes	
Setting	Description
OFF - Default	<p>Scale changes will be applied immediately when edited with the 'Scal' knob 3. No confirmation is required. Existing sequencer steps remain in their original position on the grid. Existing steps may therefore be set to another note in the new scale. Intervals remain the same. No quantization is applied. Good for experimenting and browsing through scales.</p> <p>Pressing [Shift] + (Scal) Knob 3 resets the scale to the chromatic default.</p>
ON	<p>Scale changes will only be applied when confirmed by holding [Shift] + pressing (Scal) - knob 3. If a scale is selected but is unconfirmed, an asterisk '*' is displayed, and the original scale remains active.</p> <p>When the scale is confirmed, sequencer steps are quantized to the new notes in the scale. This means existing steps are moved and relocated in the new scale grid to a note as near as possible to those set in the original scale. Better for switching between scales directly and maintaining a musical transition.</p>

### Examples:

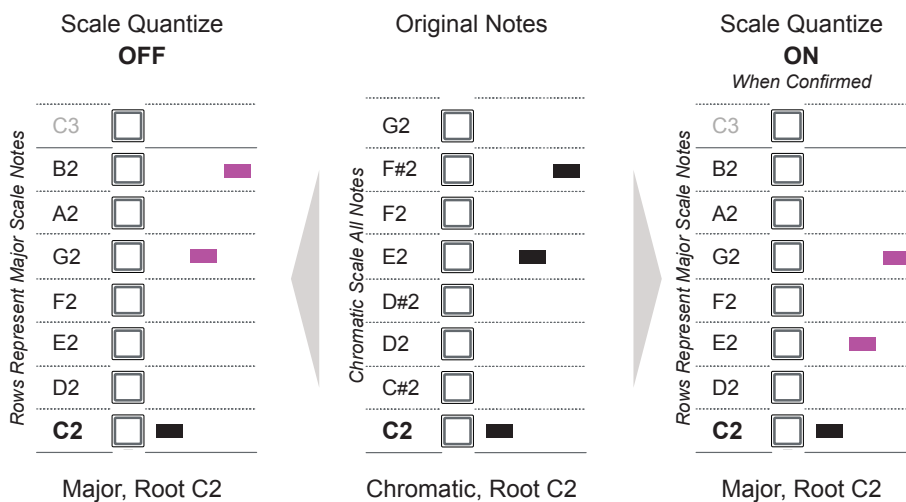

—Note—  
 Incoming notes from an external MIDI device or the internal ONE keyboard will also be quantized based on the scale quantize setting.

## 3.15 Sequencer Behavior

The sequencer settings include a number of configuration settings, most of which are covered under the relevant topic in the manual. It is useful to understand some of the fundamental synchronization and transposition behaviours of the sequencers.

These are part of the sequencer settings pages which are accessed using [Shift] + Seq [1] - [8] and tapping [Page] to navigate pages.

### Punch-In Quantization.

Punch-in quantization is basically the countdown that takes place before a sequencer is made active using mute or starts playing after pressing play. For example unmuting / activating or resetting a sequencer. This countdown synchronizes the sequencers and manages the playback timing to restart the transport bar at step 1. This setting is saved with the project.

The punch-in parameter is called 'In' and is set using knob 1. The  symbol suggest that playback may be interrupted or delayed slightly if changing this setting on-the-fly.

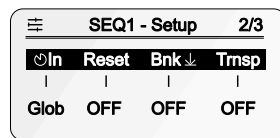

### Sequencer Settings - Page 2

The (In) Knob 1 option sets the punch-in quantization setting. The  symbol indicated that there may be a delay in the pattern when adjusting this setting.

### 'In' Parameter Options

- **Glob.** Global uses the global / load quantization set for the project. Global / load quantization is set in the arranger options and is used for project and pattern loading. Glob is the default 'In' setting.
- **OFF.** Turns punch-in quantization off. Play or reset is performed immediately.
- **P.End.** Resets or starts playback at the end of the current pattern.
- **Beat, 1/2 Bar, Bar, 2, 4, 8 Bars.** Resets or starts playback at the end of the period selected.

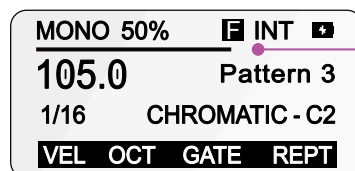

Punch-in quantization will be determined at the end of the bar duration set or pattern end. The load bar indicator is used as a guide.

## 3 Sequencer Basics

### Reset.

Reset will define if or how the playback of the sequencer is automatically reset during playback. This can be set between Off, 1 - 64 bars and defines how long the pattern will play before resetting to the start. This a useful feature for re-synchronising patterns and especially multitrack tracks when time divisions are adjusted. Reset is adjusted using (Reset), Knob 2. This is related to the internal sequencer and does not relate to the physical analog output.

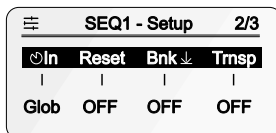

### Sequencer Settings - Page 2

The (Reset) Knob 2 option sets the duration of playback before resetting the sequencers.

### Transpose.

Enables or disables the note transposition from an external device on the sequencer. Transposition is based on the root/base note of the sequencer or track. When this is in operation the incoming notes do not affect the arp, recording etc. Note off is ignored. Transpose operates even if MIDI channel filtering is off.

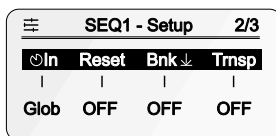

### Sequencer Settings - Page 2

The (Trnsp) Knob 4 option sets MIDI behavior for transposing the sequencers.

### 'Trnsp' Parameter Options

- **Off.** Disabled.
- **Same.** Evaluates the incoming MIDI note and checks the match of its channel to the equivalent channel sequencer for transposition.
- **Ch 1 - Ch 16.** All notes are used from the respective channel to transpose the pattern. Sequencers can be set to the same MIDI channel which can then be used for collective transposition when a note on message is received.

### Bank.

Bank defines the MIDI bank LSB or MSB number that is transmitted on the sequencer MIDI channel and output destination when a pattern is loaded. Also operates in the arranger. The bank setting must be confirmed by tapping the knob after editing.

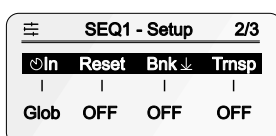

### Sequencer Settings - Page 2

The (Bnk) Knob 3 option sent a MIDI bank message. Tap knob to confirm selection.

NOTES



# Creating Patterns

Patterns are the building blocks for any sequenced song or arrangement and this section focuses on the holistic creation, management and playback of patterns. This is a high level view of patterns in general Focusing on workflow and does not aim to cover intricate details of individual steps. Step level edits and topics are covered in more detail in other sections. A number of common editing options and functions that apply across an entire pattern are included some of which may also be applicable globally. The starting point is configuring patterns, setting the length, time division and the general editing of existing groups of steps. Some generic features that apply across the pattern such as grooves are also covered. In addition some interesting generative and pattern options are also included especially Focusing on the pattern 'GEN' generator function and the process of recording patterns. This chapter builds from the viewpoint of manual sequencing of steps, recording and widens the workflow across a complete pattern generation and creation.

# 4 Creating Patterns

## 4.1 Pattern Length

A pattern can be up to 128 steps in length, configured across 8 pages, each consisting of a maximum of 16 steps. These steps are viewed and editing across the 8 x 16 pad grid. Default is 16 steps. The pattern will play from its initial start position to the end, then restart and continue in this forwards cycle. Play direction is set in the [Track] menu options.

### Editing Pattern Length

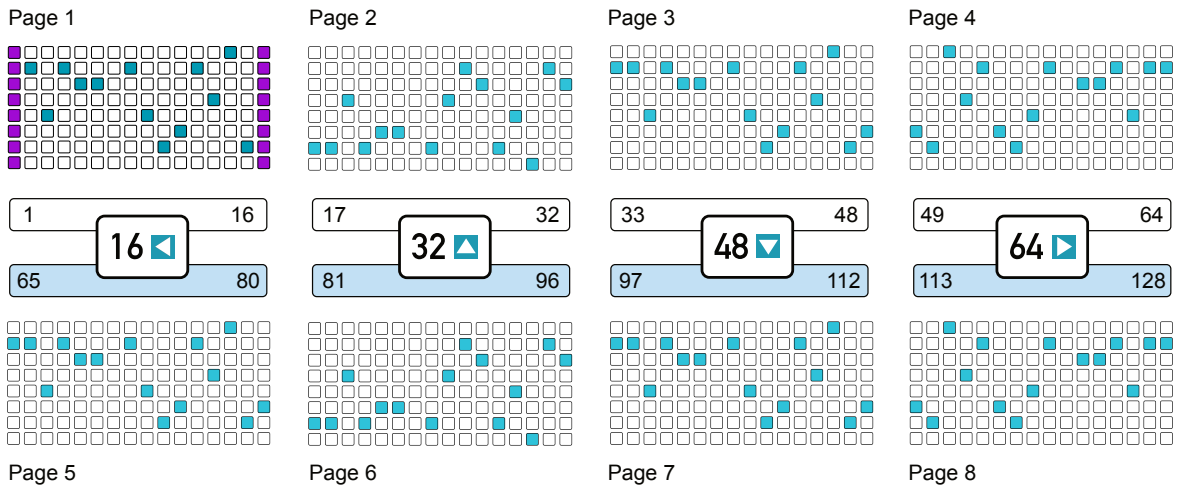

Tap a page [16] - [64] button to navigate pages 1-4, page button is lit white.  
 Tap x2 or hold seq [1] - [8] + [16] - [64] to access pages 5-8, page button is lit blue.

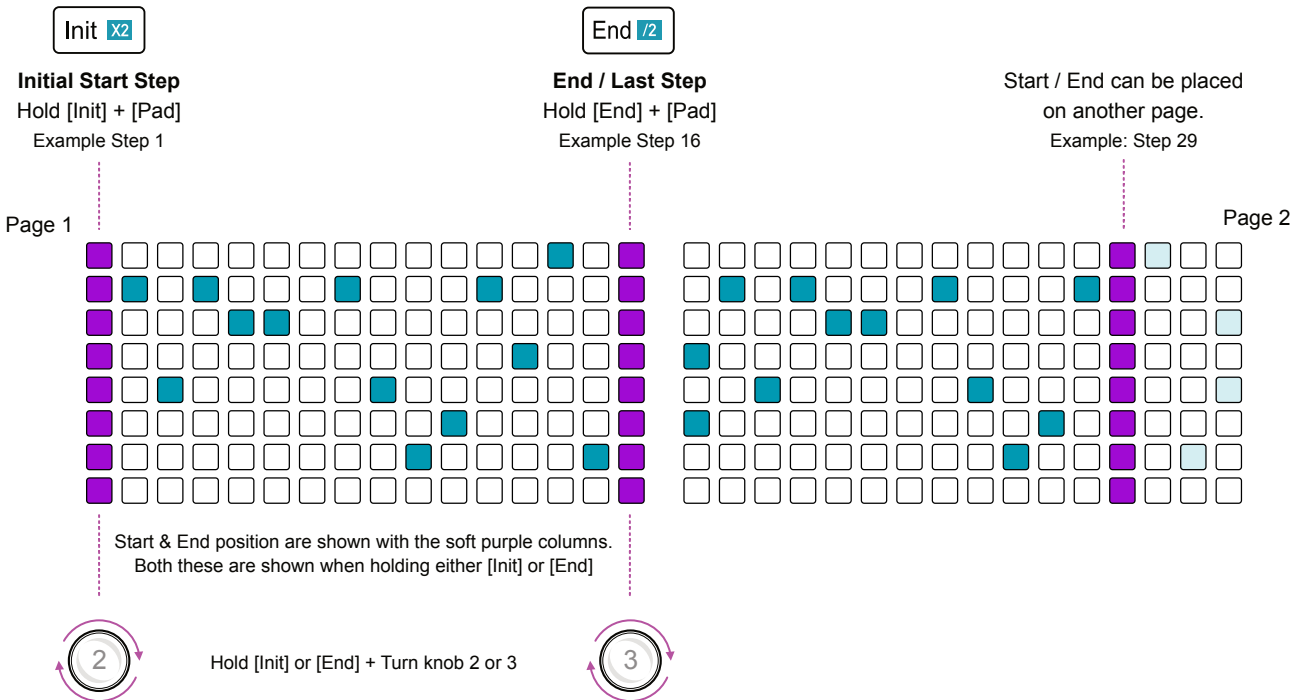

Length can be set individually per sequencer. Also each track in multitrack mode can be set to an independent length.

## Setting the Pattern Start / End



or



Select the initial first step in the pattern using [Init] + [Pad] for the column that represents the start position. Start and end column positions are lit soft purple while holding Init.

Hold [Init] or [End] + turn (Knob 2). Alternative to set the first step.



or



Select the last step in the pattern using [End] + [Pad] for the column that represents the end step position. Start and end column positions are lit soft purple while holding Init.

Hold [Init] or [End] + turn (Knob 3). Alternative to set the last step.

Start and end can be set anywhere across any page. Lengths can be set different for each sequencer and different for each track in multitrack mode.

Setting the initial first step beyond the end position will move both the start and end positions relatively. So if a length of 1-8 steps is set up, selecting step 17 for the init start, will move the start to step 17 and also move the end from the original step 8 and locate it at step 24.

## Shifting the Pattern Start & End

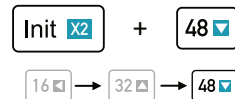

Moves the start and end positions together to another higher page. The relative start and end positions remain in tact when moved to the another, higher page from the current one.

If moving to a lower page, only the start position is moved.

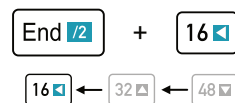

Moves the start and end positions together to another lower page. The relative start and end positions remain in tact when moved to the another, lower page from the current one.

If moving to a higher page, only the end position is moved.



Double tapping the page buttons switches the range that the button covers. Example: Default 1-16, button lit white, tap again for 65-80, button lit turquoise.

# 4 Creating Patterns

## 4.2 Time Division

The time division sets the musical resolution of a pattern. These are set in note value intervals such as 1/16<sup>th</sup>, 1/8<sup>th</sup> etc and the current value is shown on the ONE main sequencer display. Time division can be set independently for each sequencer or track in the case of multitrack and matriceal modes.

Time signature is more around the musical structure of a pattern. This assigns the number of beats per measure / bar, designated by the signature upper number, and the note value for each beat represented by the lower number. So time signatures can be written as common time 4/4, 3/4, 2/4, etc.

### Changing the Time Division

The time division is set per sequencer within the track menu. Other sequencer specific parameters also can be found in the menu such as navigating the octave range, playback direction and random time division option.



Tap [Track] to open the track menu.  
Hold to temporarily view.

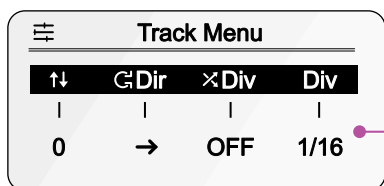

Track Menu

Time division for the selected sequencer

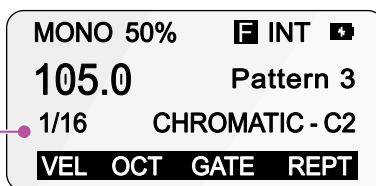

Main Sequencer View



Turn (Div) Knob 4 in the track menu for the selected sequencer to change the time division.



+



The option to quickly double the sequencer time division from its current value is possible by holding [Shift] + tap [Init].



+



The option to quickly halve the sequencer time division from its current value is possible by holding [Shift] + tap [End].

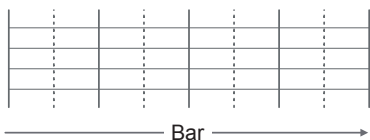

Example 1/8<sup>th</sup>



Example 1/16<sup>th</sup>

Time division options:  
Bar, 1/2, 1/4, 1/8, 1/8t, 1/16, 1/16t,  
1/32, 1/32t, 1/64.

Triplets are available and indicated by 't'.  
A triplet places 3 notes into the time period of 2.

The default 1/16 time division is represented by the 16 steps on each grid page, in this example 1 bar, also called a measure.

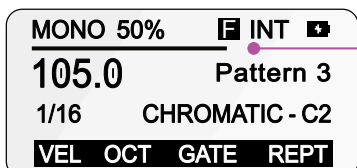

The progress bar graph on the display will show each musical bar / measure in real-time as it is played dynamically in the sequencer.

This helps identify the load quantization.

While time division can be set precisely in the track menu for each sequencer, a couple of quick edit options are also available directly from the function buttons to expand or condense the sequencer time division.

## Expand or Condense

**Shift** + **Page expand** **Expand Length.**  
Hold [Shift] + tap [Page] to zoom the pattern by doubling the length while halving the time division, increasing its note resolution.

**Shift** + **LFO condense** **Condense Length.**  
Hold [Shift] + tap [LFO] to contract the pattern by halving the length while doubling the time division, reducing its note resolution.

## Examples

### Original Pattern

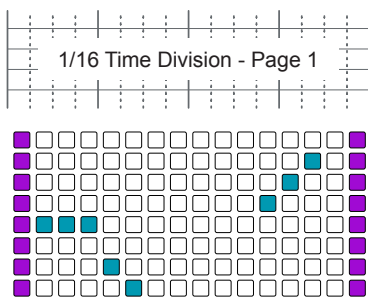

**Page expand**

### Expanded Pattern

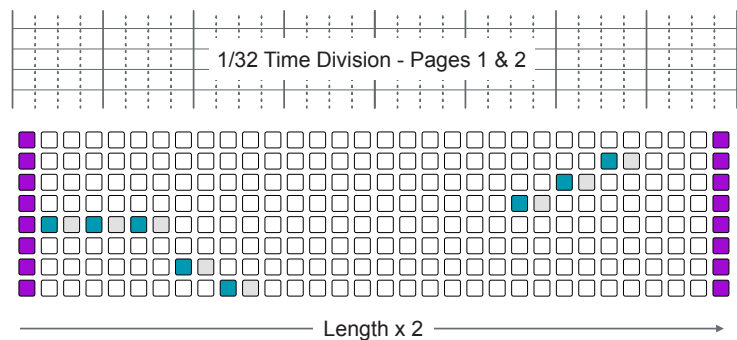

Pattern expands over 2 pages, 32 steps with a time division moving from 1/16 to 1/32. The end position is automatically relocated and the note timing is maintained. Notes, along with ties, shift relative to the original relative position. Expand is limited by the maximum number of 128 steps.

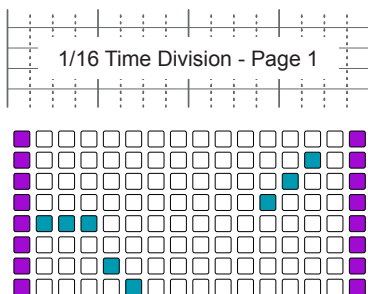

**LFO condense**

### Condensed Pattern

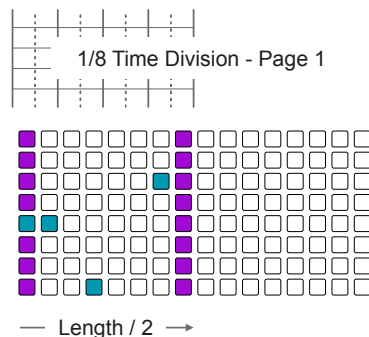

Some notes are lost.  
The expand and condense functions can be undone / redone.

Pattern is condensed in the same page, to 8 steps with a time division moving from 1/16 to 1/8. The end position is automatically relocated and the notes retain their relative timing but are re-positioned, in order to represent the original position. This is a destructive process in that some notes may be removed when condensing the pattern.

## 4 Creating Patterns

### Randomizing the Time Division

The time division is normally fixed per sequencer. However to add more unpredictability and expand the creative options, the track menu has a time division randomization feature. This can be set to a value between Off, 1% - 100% to apply an amount of variation to the time division value while the sequencer pattern is playing. Default is Off. In multitrack mode each track can be randomized individually using the track 'Div' randomization.



Tap [Track] to open the track menu.  
Hold to temporarily view.

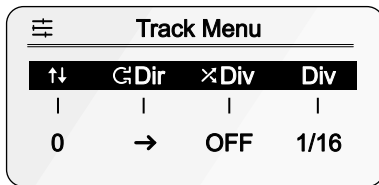

Track Menu

The sequencer will maintain its clock tempo but may be out of synchronisation due to the applied randomization.



Turn (xDiv) Knob 3 in the track menu to apply an amount of variation to the time division. Hold (xDiv) to reset the parameter to the default 'OFF'.

—Note—

The arp time division can be set independently from the sequencer division. This is set in the Arp settings. The time division for the sequencer is important for multiple functions other than the standard note timing. For example repeats.

### 4.3 Playback Direction

The direction of playback for each individual sequencer can be controlled from the track menu. This also applies each track in multitrack mode.

Track follow Tap [Track] to open the track menu. Hold to temporarily view.

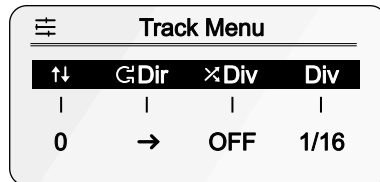

Track Menu



Turn (Dir) Knob 2 in the track menu to change the playback direction of the selected sequencer or track.

#### Forwards - Default

The sequencer will play forwards, start to end, then continues back from the starting position.

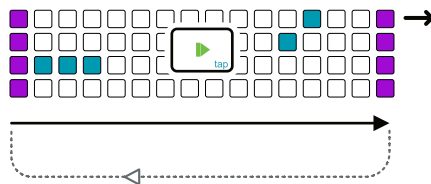

#### Reverse

The sequencer will play backwards, end to start, then continues, starting from the end.

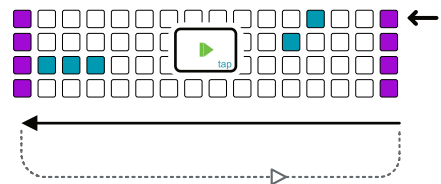

#### Pendulum

The sequencer will play forwards, start to end to start, then continues in this pattern. Step will play twice when reversing the cycle

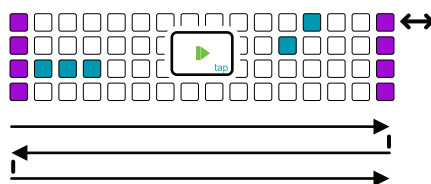

#### Random

The sequencer will play any individual step in an unpredictable random order.

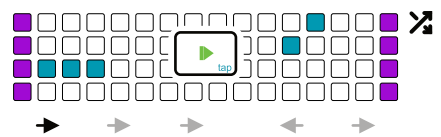

#### Drunk

The sequencer will play with a chance algorithm, 50% chance to advance, 25% repeat step, 25% chance to back up.

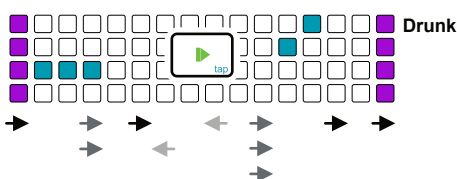

#### Pong

The sequencer will play forwards, start to end to start, then continues in this pattern. Step will play once when reversing the cycle

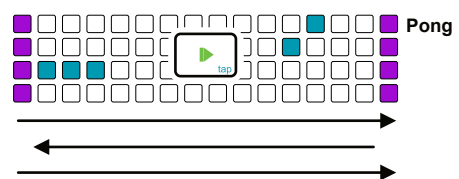

# 4 Creating Patterns

## 4.4 Shifting & Copying Steps

The fundamental process for creating patterns is to add individual steps at appropriate locations in the sequencer in order to create melodies or beats. Once a pattern is created, steps can be edited, shifted or moved collectively on the grid.

### Moving the Step Sequence

Moves the entire sequence forwards, backwards, up or down over the grid. This moves the entire sequence located within the start and end points and will wrap the sequence across the edges. Steps will be relocated affecting the step timing when moved forwards or back and note pitch values up and down.

Sequence moves 1 step every key combo press.  
Only applies to the active steps in the range

Transpose Up/Down

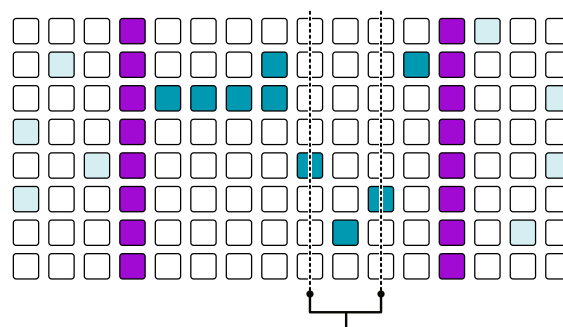
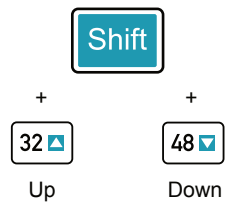

Rotate Forward/Back

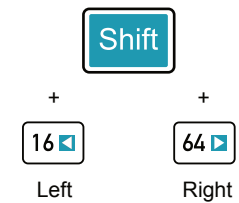

Press and hold two other column pads while using the shift + arrows to shift only the step in-between them.

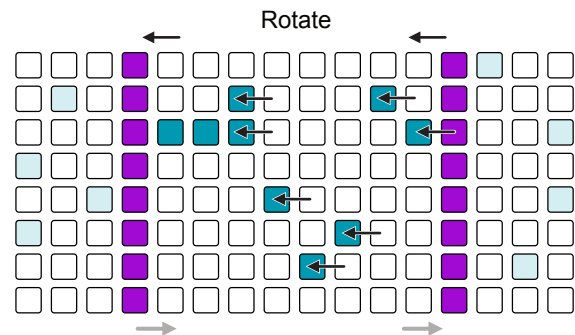
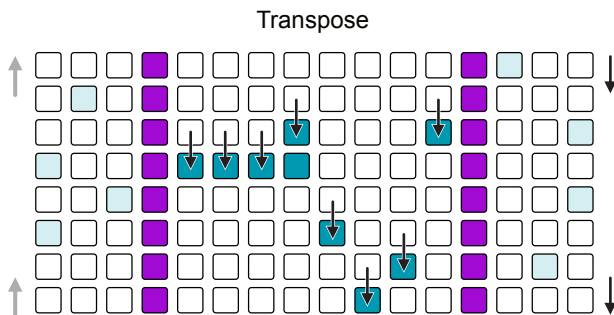

### Duplicating Steps

It is possible to duplicate steps from the current sequence, between the start and end, into the range directly following. This will automatically reset the end locator to the new, extended position. Any existing notes in the destination inactive range will be overwritten. If duplication exceeds the available step count then the number of steps will be duplicated up to the limit of 128.

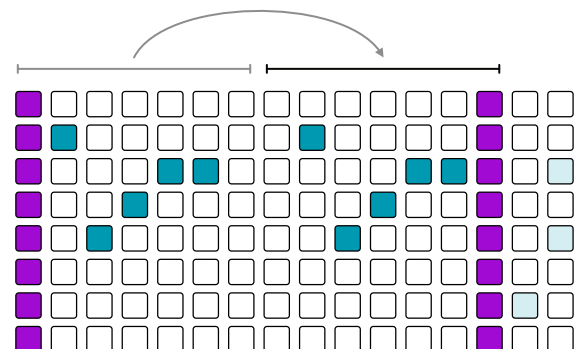
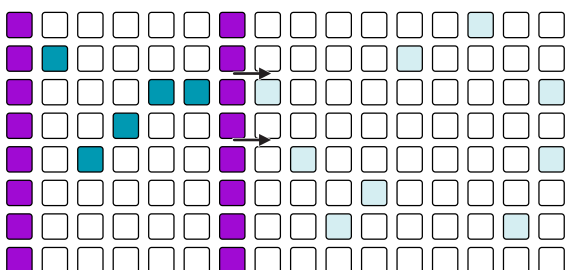
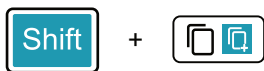

## Shifting the Sequence



Shift the sequence earlier / left or later / right on the grid by 1 step for each press of the button combo. Only steps within active start / end range are affected.



Shift the sequence up or down on the grid by 1 note step for each press of the button combo. Only steps within active start / end range are affected.



Holding two pads spanning a range column-to-column and using the [Shift] + [16], [32], [48], or [64] commands above will shift only the sequence elements between the two selected columns.

## Duplicating the Sequence



Duplicate the sequence section between the start and end points. Hold [Shift] + [Copy]. Doubles the sequence. Existing out of range notes are overwritten and the end point is repositioned.

## Copying / Pasting Patterns



Copy a pattern. In the load or save menu copy and paste using the pattern grid. Hold [Copy] + hold [Pad] for the source pattern to copy, any sequencer. Message will confirm completion.



Paste a pattern. In the load or save menu copy and paste using the pattern grid. Hold [Paste] + hold [Pad] for any sequencer destination slot to paste into. Message will confirm completion.

## Copying / Pasting Steps



Copy a pattern page. Hold [Copy] + hold [16], [32], [48] or [64] for the source page to copy. Message will indicate when copying is complete.



Paste a pattern page. Hold [Paste] + hold [16], [32], [48] or [64] for the destination page to paste into. Message will indicate when pasting is complete.



Copy a step. Hold [Copy] + hold [Pad] for the source step pad and its parameters to copy. Also covers copying tied and multiple steps. Message will confirm completion.



Paste a step. Hold [Paste] + hold [Pad] for the destination step pad to paste into. Also pastes tied and multiple steps. Pastes any new values relative to original value ie pitch. Message will confirm.



Copy a sequencer, all steps. Hold [Copy] + hold [1] - [8] for the source sequence to copy. Message will indicate when copying is complete.



Paste a sequencer, all steps. Hold [Paste] + hold [1] - [8] for the destination to copy into. Message will confirm completion.

### 4.5 Clearing Steps

Erasing all steps is possible from a sequencer as well as clearing the complete sequencer including its settings such as time division, length etc. Removing an individual step is as simple as tapping the pad, although the config can be set to reassign the step with its previous parameters. Full projects and patterns can also be cleared in the save menu which is more encompassing by clearing settings such as MIDI channel and MOD destinations.

#### Clearing the Sequence



+



Tap

To clear the selected sequencer's note events. Hold [Shift] + tap [Clear]. A 'CLEAR' message is displayed. This clear command can be undone with the [Undo] button.



+



Hold

To fully clear the selected sequencer's note events and resets settings to their default values. Hold [Shift] + hold [Clear]. A 'FULL CLEAR' message is displayed.

These functions can also be used to clear each selected track in a multitrack sequencer.

### 4.6 Nudge Sequencer Timing

The timing of all sequencers can be adjusted. Changes can be made in milliseconds which will affect all steps, nudging the sequencer backwards / right and forwards / left. This is controlled from the nudge page accessed using [Shift] + [Mute]. This nudges all sequencers between -100 to +100 milliseconds.

#### Nudge

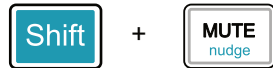

Hold [Shift] + tap [Mute] to open the global nudge menu covering each of the 8 sequencers.

↔ Time Offset [ms]			
SQ 1	SQ 2	SQ 3	SQ 4
+11	-25	+0	+0
SQ 5	SQ 6	SQ 7	SQ 8
+0	+0	+0	+0

Nudge Menu



Turn the respective knob to edit the timing offset for the chosen sequencer, labelled SQ. Tap knob to switch between an upper 1-4 sequencer and lower 5-8.

Hold a knob to reset the value.

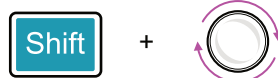

In this menu, hold [Shift] + turn any knob to edit the timing offset for all of the sequencers simultaneously.

As a point of reference an 120 BPM track will have 0.5 sec per beat. So at 1/16<sup>th</sup> note intervals each step is 0.125ms. Meaning the maximum + or - nudge range will be within this note interval of 1 step. The grid steps will not display any visual movement when editing nudge in this example but the micro timing of the sequencer is still affected.

## 4 Creating Patterns

### 4.7 Time Bend Sequencer Speed

The playback speed can be adjusted for all sequencers using the time bend function accessed using [Shift] + double tap [Mute]. This adjusts the speed up or down by a percentage with respect to global tempo. The percentage adjustment is in the range -12% to +12%.

#### Time Bend



Hold [Shift] + double tap [Mute] to open the global time bend menu covering each of the 8 sequencers.

Time Bend			
SQ 1	SQ 2	SQ 3	SQ 4
2.1%	0.0%	0.0%	0.0%
SQ 5	SQ 6	SQ 7	SQ 8
0.0%	0.0%	0.0%	0.0%

Time Bend Menu



Turn the respective Knob to edit the time bend for the chosen sequencer, labelled SQ. Tap knob to switch between an upper 1-4 sequencer and lower 5-8.

Hold a knob to reset the value.

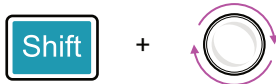

In this menu, hold [Shift] + turn any knob to edit the time bend for all of the sequencers simultaneously.

### 4.8 Swing

Patterns can be created to a rigid grid where timing is perfect and repetition predictable. But this may lack interest and be too robotic. In music, especially with digitally produced productions it is important to consider a human feel for the pattern. Swing adds some natural timing. Swing can be adjusted per sequencer and saved with the pattern.

#### Swing

Swing adds some natural offset into certain notes in a pattern. This adds a natural less rigid feel to the rhythm and beat of a pattern. Swing is readily available from the main sequencer view in the secondary parameter options and can easily be edited for the selected pattern. Swing is set between 10-90% with 50% the default meaning no swing is applied.

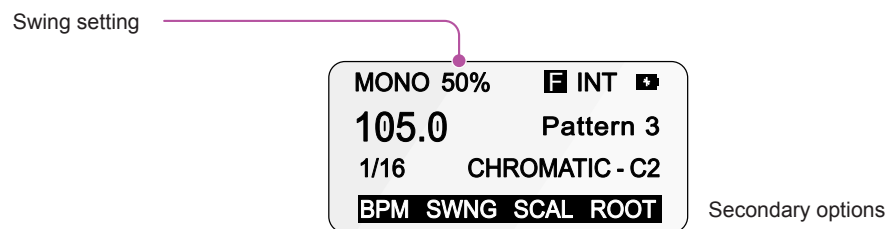

Shift to open the secondary parameters



+



Turn (Swng) to edit swing for the selected sequencer. Swing is saved with the pattern. Hold [Shift] + hold [Swng] to reset value.

## 4 Creating Patterns

### 4.9 Groove

Another feature that adds a more natural feel to a pattern is the groove. A groove is a preset template that applies a predefined timing shift to specific steps as well as applying a groove velocity profile to steps. Groove velocity accents are also applied to repeats but groove timing is only applied to the original note. This introduces a more natural, but predictable rhythmic feel. Groove has a subtle effect on the timing and velocity structure of a pattern, adding character and personality.

A groove can be edited and adjusted for the sequencer and groove templates can be loaded to the OXI MkII from the OXI App. The OXI App also has an integrated groove builder. Grooves can also be created in Ableton Live or other 3<sup>rd</sup> party tools and imported to ONE.

Groove Menu



+



Opens the global groove settings menu.

Other groove options can be found integrated into other functions.

..ll Groove			
Accnt	Time	Offst	Grov
+0%	0%	+0	Tran
-	Len	Rand	-
-	16	0%	-

Turn a knob to edit the respective parameter.

Hold knob to reset the value to the default setting.

Groove Parameters			
Accnt	Time	Offst	Grov
Velocity Accent Amount	Note Timing Amount	Offset	Groove Template
Sets the + or - amount of velocity accent applied (includes repeats), based on the groove template velocity profile. Range is -120% to 120% with 0% default.	Sets the + or - amount of timing applied (notes only, not repeats), based on the groove template for the actual pattern note timing. Range is -120% to 120% with 0% default.	Shifts the groove pattern left / earlier or right / later with respect to the step pattern.	Selects a groove template from the on-board library. More can be added or created using the OXI App and the options in groove browser page.
	Len	Rand	
	Groove Pattern Length	Random	
	Length of the groove pattern cycle. Maximum range will be based on the groove template length, typically 16 or 32.	Randomizes the amount of groove applied from the template. Range 0-100%.	

**Grov. Groove Templates.** The factory on-board groove templates are listed below. Any grooves transferred into OXI ONE using the OXI App will appear starting at number 15 in the groove library list. The groove parameters will apply the template profile in the amounts set by the global groove page parameters

Number	Name
1	Trancey Groove 16th
2	Disco Light Swing 16th
3	Tambourin 16th
4	Bomba Acc 16th
5	Shaker ChaCha 16th
6	Loosely Flow 16th
7	Claves Accent 16th

Number	Name
8	Caixa Accent 16th
9	Charanga Shaker 16th
10	Dancehall 16th
11	Disco Indie 16th
12	Fusion Tight 16th
13	African Timbales 16th
14	Quinta Loca 16th

## OXI App Groove Templates

Groove templates can be created in the OXI App. These, as well as other templates, for example from Ableton Live can also be dragged and dropped from the PC / Mac folder and into the microSD Card groove folder. The templates will then be accessible in the groove 'Groov' template library. Further details on working with the app are covered in another section. Grooves can be imported and exported using the OXI App.

### OXI App

+ Create a new groove

✎ Edit the groove

⋮ Delete the groove

Drag grooves from the PC/Mac and drop over to the OXI ONE device.

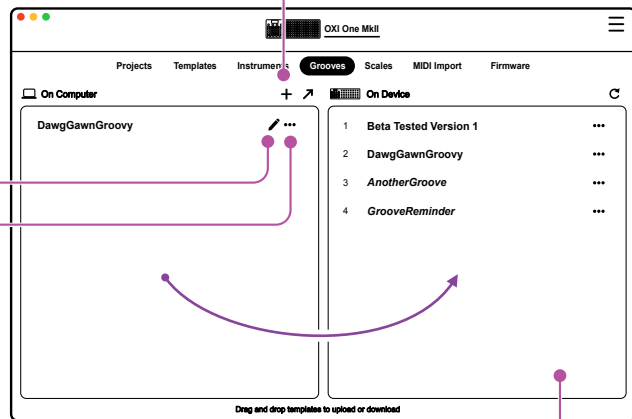

microSD Card grooves  
On-board Oxi ONE

The groove builder creates the number of steps, velocity and step timing mapped for each step.

Groove name can be edited in the tool.

The groove is initially saved on the PC/Mac.

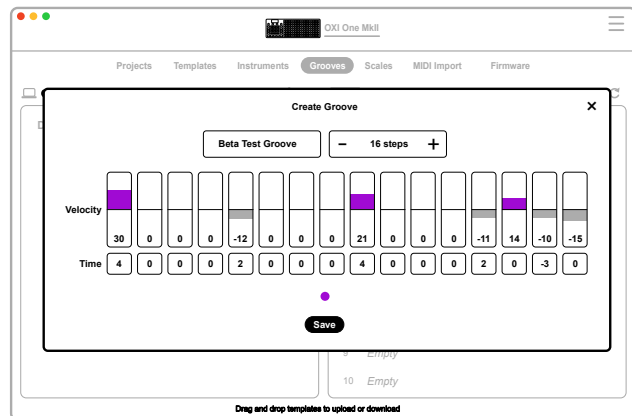

The template, once copied to the device, can be loaded to the sequencer. The groove settings will then apply the amounts and set the behavior of how the template operates.

It is recommended to create a PC/Mac master location folder when first using the OXI ONE App. This is performed from the project tab, 'select a storage directory' option using the cog icon.

- ! **Use external grooves with caution.** The use of external grooves should be handled with care due to the variety of third party options and formats that can be used to create grooves.
- Externally created grooves cannot be predicted or guaranteed when used in OXI ONE.

## 4 Creating Patterns

### 4.10 Euclidean Pattern Generator

Generator is a tool used to create entire pattern sequences. At the heart of the generator is a 2-layer Euclidean engine. Each Euclidean layer places notes into the selected sequencer grid based on a mathematical model which takes its input from the parameter settings applied. The ONE Euclidean generator applies the rhythmic positioning of notes as well as assigning notes from the selected scale, starting with the current root.

Generator is a destructive tool meaning existing note steps will be overwritten unless locked or fixed in which case these steps are protected.

#### Euclidean Generator

The core concept of a Euclidean generator is to take several parameters and apply a mathematical model to generate a pattern. The two main parameters are the length and the pulses. The Euclidean engine then distributes pulses as evenly as possible across the defined length. Other parameters, for example rotation, can also be applied to enhance the function further.

Generator works on the currently selected sequencer or track if in a multi track sequencer.

**Generator Menu.**  
Tap [Gen]



Tap [Gen] to open the Euclidean generator parameter options for the specifically selected sequencer or track. Hold [Gen] to temporary open, close when released.

**Change Page.**  
2 x Pages



Tap [Gen] or [Page] within the generator function to switch between the available pages. Page button flashes when multiple pages exist.

**Change a Parameter**  
Real-Time Activation



Turn any knob to edit the specific parameter in-focus. The changes are made real time and will impact immediately.

**Edit a Parameter**  
Delayed Activation



+



Hold [Shift] + turn any knob to edit specific parameter in-focus. The changes will not become active until a real-time edit is made. *Delayed edits are not retained when closing the [Gen] page.*

## Page 1 - Layer 1 + Rhythm & Pitch

General Sequencer View

GEN				1/2
eLen	ePuls	eRot	Dens	
16	7	0	+0%	
NteR	Not%	OctR	eInv	
0st	30%	0oct	No	

Multi Track View

GEN T:3				1/2
eLen	ePuls	eRot	Dens	
16	7	0	+0%	
NteR	Nte%	OctR	eInv	
0st	30%	0oct	No	

↑ Tap a knob to change its focus between the upper and lower parameter. Change pages with the [Page] or [Gen] button.

Generator Parameters			Page 1/2
<b>eLen</b> Euclidean Length - Layer 1	<b>ePuls</b> Euclidean Pulses - Layer 1	<b>eRot</b> Euclidean Rotation - Layer 1	<b>Dens</b> Density
Length in steps of the Euclidean pattern layer 1. Pulses will be applied across this range.	Number of layer 1 Euclidean pulses to generate across the length of the pattern, spread evenly.	Rotation of the Euclidean pattern. All layer 1 steps are shifted forward or back.	The density and population of more / less steps in the pattern. Set as a percentage -100% to +100%.
<b>NteR</b> Note Randomization	<b>Nte%</b> Probability	<b>OctR</b> Octave Range	<b>eInv</b> Euclidean Inversion
Range in scale note intervals of additional randomized notes. Range 0 to +24st or +/-24st.	Sets the probability of randomization. Range is 0-100%.	Octave range which allows notes in other octaves to be added to the generated pattern. Range is 0 to +3 or +/- 3 oct.	Inverts the entire later 1 and 2 pattern. Active steps become inactive. Inactive steps become active.

## Page 2 - Layer 2 + Note Distribution

General Sequencer View

GEN T:3				2/2
Tie%	eLen2	eRot2	NtOrd	
OFF	OFF	0	Lin	
Lock	ePul2	Logic	Vel%	
OFF	OFF	OR	OFF	

Multi Track View

GEN				2/2
Tie%	eLen2	eRot2	NtOrd	
OFF	OFF	0	Lin	
Lock	ePul2	Logic	Vel%	
OFF	OFF	OR	OFF	

↑ Tap a knob to change its focus between the upper and lower parameter. Change pages with the [Page] or [Gen] button.

Generator Parameters			Page 2/2
<b>Tie%</b> Tie Probability	<b>eLen2</b> Euclidean Pulses - Layer 2	<b>eRot2</b> Euclidean Rotation - Layer 2	<b>NtOrd</b> Note Order
The probability percentage that notes in layer 1 and 2 are tied together.	Length in steps of the Euclidean pattern layer 2. Pulses will be applied across this range.	Rotation of the Euclidean pattern. All layer 2 steps are shifted forward or back.	The method of applying notes to steps. Linear is the traditional method, evenly laying notes. Random, PingPong and Shuffle are other options.
<b>Lock</b> Lock Protection	<b>ePuls2%</b> Euclidean Pulses - Layer 2	<b>Logic</b> Output logic - combined layers	<b>Vel%</b> Velocity Variation
Off or set to lock the note pitch, rhythmic position or both. Prevents any further edits and is applied to layer 1 and 2.	Number of layer 2 Euclidean pulses to generate across the length of the pattern, spread evenly.	The logic applied to how both layer 1 and layer 2 combine to create a final, actual pattern.	Percentage amount of variation applied to the velocity of generated notes.

Hold a knob to reset its parameter value back to the default setting. Tagged parameters are modulatable.

# 4 Creating Patterns

## Euclidean concepts

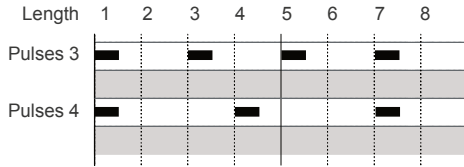

Length in Steps

A Euclidean generator needs a time duration, This can be set in step count to determine the overall length to operate within.

### Pulses

Pulses are the actual triggers within the time period that generate notes. A Euclidean generator takes the selected number of pulses and distributed them as evenly as possible across the time period. This is the default 'Linear' behavior in ONE. Other options are available to randomly apply notes, shuffle or page to page. Pulses can also be rotated earlier or later in the pattern.

### Layer 1 and 2

The OXI ONE Euclidean generator operates with the unique feature of dual layers. Think of this as 2 Euclidean generators. The outputs are then combined using the logical rules set with the 'Logic' parameter. The overall result creates the final pulse output.

### Example. Euclidean Patterns

Length: 16, Pulse: 7, Linear Note Order



The 7 pulses are distributed as evenly as possible over the 16 step range.

Rotate: +2 → →



Pulses can be rotated left/forwards and right/backwards, wrapping at the length start/end.

Logic OR

Length: 16, Pulse: 3, Linear Note Order



=



Logical OR: If either layer has a pulse it will generate an equivalent step pulse at the output

Logical AND: Both layers must have a pulse on the same step to generate an equivalent step pulse at the output

Logical XOR: If both layers have a pulse on the same step, there is no equivalent step pulse at the output

Acct: Layer 1 determines the rhythmic step placement. If a layer 2 pulse step matches a pulse on layer 1, then the step is accented.

Invert: Yes



Pulses can be inverted. When Inv is 'yes' the inactive pulses become active and vice versa.

NOTES

# 4 Creating Patterns



MO PO MT CH

## 4.11 Random Generator

OXI ONE can generate random patterns for mono, poly, multi and chord modes using the randomizer. Random pattern generation is a destructive process, overwriting any previous data. The random generator function is the secondary option in the randomizer, accessed using [Shift] + [Randomizer]. The random perform option is explained in a later section.

### Random Pattern Generator

The principle of the random pattern generator is to create a random rhythmic and melodic pattern within the boundaries of the set parameters. The pattern can then be further tuned and tweaked manually to shape the composition. The starting point is therefore to setup the randomizer parameters in which to work.

Random generator menu  +  Hold [Shift] + Tap [Randomizer] to open the random generator options and menu.

 Alternatively, Tap [Randomizer] to cycle through the random perform & generator pages.

Generate a pattern  Each tap of (Den), Knob 4 will generate a new pattern in the current sequencer.

The pattern generated will be created within the boundaries of the parameters set in the random generator page. These can be edited for each pattern generated or simply tap (Den) several times to see what patterns are generated. The pattern can be edited manually once created.

✕ Random Generator

Bias	Rang	Rand	Den ↓
0	+12st	25%	70%
Scal	V & G	Ties	-
No	10%	10%	

### Randomizer - Pattern Generator

Parameters can be set prior to generating a pattern in order to establish the framework from which to create the melodic and rhythmic pattern. Tap a knob to switch between the upper and lower parameter. Hold a knob to reset its value.

Random Generator Parameters			
Bias	Rang	Rand	Den
Root note offset	Range of note intervals	Note Randomization	Density of notes
Sets root note offset that is the central element to build the pattern around. Rang parameter will use this as its reference. Bias range is -10 to +10, default 0.	Sets range of note step intervals. Generates new notes in this defined range, above or below + below the bias setting. Range is in semitones, -/+24 to 0 to +24.	Degree of variation in the notes generated. Lower values generate more consistent and repetitive patterns. Higher values create less varied, less predictable patterns. 0-100%	Sets the amount of notes generated. Set as a % or sets the parameter option that affects the behavior of the generated notes. <u>Press (Den) to generate pattern</u>
Scal	V & G	Ties	
Random Scale & Root	Velocity & Gate variation	Probability of tied notes	
Yes - will allow the scale and root note to be randomized. No - sequencer scale and root note will remain during randomization. Default is No.	Sets the range of variation for applying a velocity and gate value to the generated notes. Off, 1% -100%. Default is 10%.	Sets a probability % of the amount of notes generated which are tied. 0% -100%. Default is 10%.	

## Density

The density control in the randomizer is very important as pressing this knob generates the randomized pattern. Parameter changes do not affect the pattern until (Den) is pressed. Density is a parameter setting that has multiple options. These include, % amount of notes when generating a new pattern. In addition the modifiers work on the behavioural options that affect the existing pattern when (Den) is pressed.

**1-100%** - Turn knob right. Sets the amount of notes generated when (Den) is pressed. New notes are generated. At 100% all steps are populated and at 1% only a small few if any at all.

**Human** - Turn knob left, earlier than 1% value. Applies a level of humanization to the existing pattern notes. Doesn't add any new notes. Affects gate and micro timing.

**Order** - Turn knob left. Re-orders the existing notes into a new sequence. The note values are retained but the order is shuffled. Creates a variation of the existing sequence. Any tied notes are not retained.

**Pitch** - Turn knob left. Changes the pitch of the existing notes in the sequence. The note values are changed but the order is retained. Creates a variation of the existing sequence. Any tied notes are not retained.

**Flip** - Turn knob left. Inverts the order of notes. Reverses the entire sequence steps in the order from start to end. This is the same sequence of notes but plays now reversed.

## Undo

The Undo function can be used when working with the random generator.

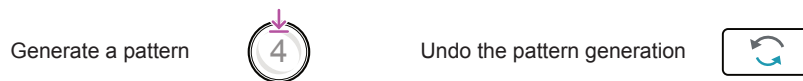

## Example workflow of generating random patterns

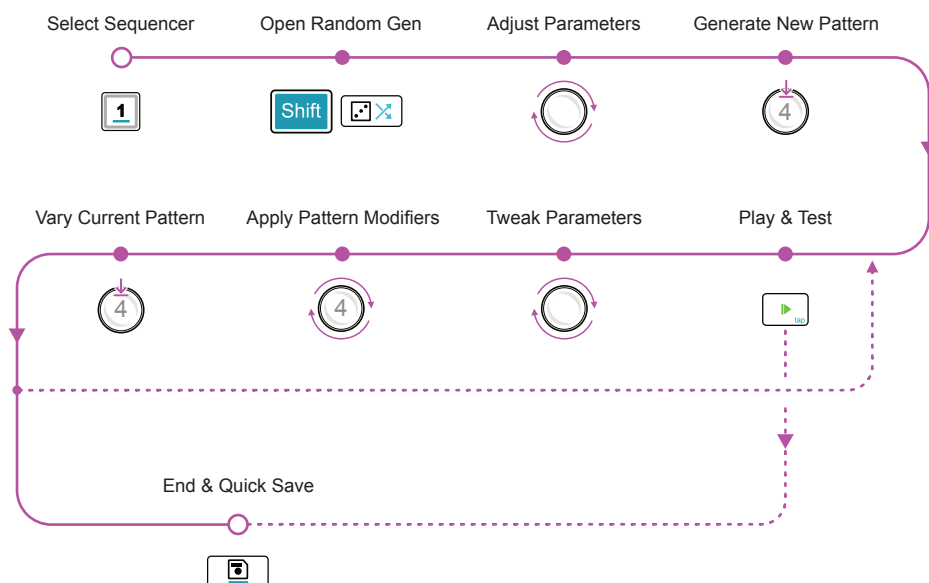

— Note —  
 Select the random generator [Randomizer]. In this view, switch between the random generator and random perform pages by tapping [Randomizer] or using [Shift] + [Randomizer].

## 4 Creating Patterns



### 4.12 Recording Patterns



Patterns can be created by recording notes from the internal keyboard or by using an external MIDI controller. Live recording will follow the same process when using either device, but some configuration differences may apply when using incoming MIDI.



There are two methods used to record; live recording will play the sequencer in real-time while notes can be played and recorded. Step recording is used either while the sequencer is playing or stopped, but either way recording follows a step by step process, programming individual notes, rests etc incrementally.

#### Live Recording

Live recording can be started with or without a record count in. This allows preparation for playing once recording starts. Also recording can be punched-in while a sequencer is already playing. Use the internal keyboard or MIDI controller to record notes.



**Live Record**   With the sequencer stopped, press [Rec], then tap [Play] to start recording. If configured, a count is displayed before recording automatically starts. Rec button is lit red.



**Punch-in Record**   With the sequencer playing, press [Rec] to immediately start recording. Rec button is lit red, play flashes.

**Stop Recording**  or  Press [Rec] to stop a recording but continue playing. Press [Stop] to stop the recording and stop playback. *Step recording not possible in Stochastic, Matriceal, Domino, Saga, MIDI Player modes.*

#### Step Recording

Step recording allows individual steps to be 'programmed' with note data incrementally while manoeuvring through the steps. Each step is programmed in series. The recording process may be familiar to users of the classic SH101 synth. Step recording is more precise but can be a slower process. Step recording not possible in Stochastic, Matriceal, Domino, Saga, MIDI Player modes.

**Step Record**  +  With the sequencer stopped or playing, hold [Rec] + tap [Play] to switch to step recording. Rec button flashes red and the step recording controls are displayed.

**Stop Recording**  +  With the sequencer recording, hold [Rec] + tap [Play] to stop and exit step recording.

Tap [Keyboard] prior to selecting step recording or use an external MIDI Keyboard. Each note press will advance the step selection, applying the played note into the active step. Tap a control for recording commands.

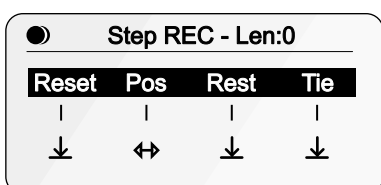

Headline shows the step selection position as 'Len X'



## MIDI Capture

The sequencers have an in-built MIDI note recording buffer. When [Keyboard] is selected or an external MIDI controller is used, the notes played will be captured into a recording buffer in the background. Recording is performed while a sequencer is playing or stopped. While playing the quantize sync status bar is displayed which helps with the buffer recording timing. The buffer can be cleared and reset or converted to notes, populated into the active sequencer. Chords will convert to the lowest note if placing into a Mono sequencer.

MIDI Capture will record: Notes, Chords, Multi-track tracks, tied notes, arp notes, the last events. Will automatically re-enable after step recording or the 'wait for input' mode.

### Select Keyboard view.

Tap [Keyboard].



Also captures external MIDI notes.

■ ■ Indicates notes are stored in the buffer



Any notes or chord played are stored in the buffer.

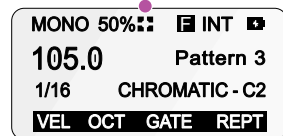

### Clear Reset Buffer.

Hold [Rec] to cancel the buffer in any view.



### Convert Buffer to Sequencer Notes.

Tap [Rec] [Rec], to place the notes into the sequencer.

## 4 Creating Patterns

### Recording Settings

A set of specific recording parameters are available. These are accessed using [Shift] + [Rec]. The behavior of recordings will depend on the sequencer mode selected.

Rec settings

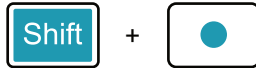

Hold [Shift] + Tap [Rec] to open the settings options.

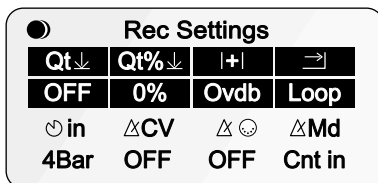

Record settings

Turn a knob to edit the setting. Tap a knob to switch between the upper and lower options. Some options require pressing to confirm the selection. These are indicated by  $\downarrow$ . Other knobs can be held to reset the value.

Recording Options			
Qt	Qt%	+	→
Recording Quantize On/Off	Time quantization percent	Overdub On/Off	Recording behavior
Toggles record quantize on or off. Tap knob to confirm change. On - automatically quantizes notes to the grid while live recording.	Amount in % of the grid interval that the notes will be quantized in the selected sequencer. Applied after or during recording. Destructive process but can be undone.	If set to Ovdb, new notes will overdub the existing note data. Existing notes are retained. If set to NoOv, No Overdub, existing notes are deleted while recording in the lane.	Loop: Records continuously as the track plays, start to end. 1Shot: Stops recording once the final step is reached. Xtend: Extends the length while recording until stopped or the max step count is reached *.
In	CV	🎹🎵	Md
Recording count-in	Metronome CV Output	Metronome MIDI Channel	Metronome
Selects the count-in duration to be applied between recording activation and the actual recording start. Options are 2 Bar, 1 Bar, 1/2 Bar, Beat or Off. Displays count-in when active.	Sets the physical CV or gate output to transmit the metronome. This is an audible 5Vpp signal or 10V gate. Take care connecting only suitable headphones or speakers for this option.	Sets the MIDI Channel which will transmit the metronome signal output. Options are OFF, Ch 1 - Ch 16.	Always: Always activate the metronome while recording. Cnt In: Only activate the metronome during the recording count-in period.

\* Xtend also allows 'MIDI live looping' with an external MIDI controller or in keyboard view. Extending a pattern while recording will not only extend the note lanes, but also the modulation lanes and the independent VEL, GATE and REPEAT lanes too. The sequence is extended 1 step at a time up to the device maximum and then at the end wraps to the start.

— Note —

The metronome CV or Gate output is 5V Peak to Peak, but can be set to 10V for gate signals. This is an audible signal. As such it is important not to damage speakers or headphones. Check for compatibility and suitability to work with your gear over this voltage range.

### Record Quantization

Record quantization ensures that notes recorded using the internal keyboard or an external MIDI controller are recorded to accurate 'on grid' timing. This will create a precise rigid structure. With quantize off, more natural, 'as played' recordings will be made. This may be desirable.

In addition, quantization can be adjusted post recording to correct or improve the timing offsets of note events. The time quantization is set as a percentage. This sets the amount that notes off grid are moved nearer to the precise grid intervals. This allows notes to be partially quantized to improve the timing but still retain an amount of natural offset. Setting this to 100% will fully close any offsets moving notes onto the grid. This is a destructive process, but the undo button can restore the previous state and remove any manually set timing offsets.

### Recording from incoming MIDI

#### MIDI Input Channel Filtering

The MIDI Input channel filtering is an option in the Config > MIDI settings which will affect the behavior of how incoming MIDI data is handled during recording. When recording is active the MIDI input is handled based on this setting. Options are:

- **OFF:** The selected sequencer will listen to any MIDI note from any MIDI channel.
- **MIDI Channel:** Each sequencer will only listen to MIDI note messages from its own defined MIDI channel. For multitrack sequencers, each track will determine the MIDI channel. When a multitrack sequencer has a global channel set for the sequencer, ie, all tracks have the same channel, only track 1 will receive the MIDI note messages.
- **CH & Note:** All sequencers will listen to their own channel. In multitrack mode, track filtering for channels applies, plus only MIDI messages that have a note matching the root note of a track are taken into account. So, the note and its channel must match the track channel and its root note.

#### MIDI In Port (A-F) Merge with Split 2

The MIDI In Port (A-F) Merge supports a connected Split 2 device. Set up is in the Config > MIDI settings, which will affect the behavior of how incoming MIDI data is handled during recording. This can be set to OFF or ON.

- **ON:** Incoming MIDI data is channeled to the MIDI port A as normal and is also channelled to MIDI ports B & C too. All data is therefore received on the equivalent matching MIDI channel for each port. This applies to MIDI USB and TRS data. OXI Split uses these ports and is a useful feature when connecting this device to OXI **ONE**.
- **OFF:** Incoming MIDI data is channeled only to the port set for communication, i.e. MIDI port A.

#### Multitrack specific considerations

- Multitrack sequencers can have each track independently configured to its own MIDI Channel. Ensure any incoming MIDI to be recorded matches to the track channel to record into. Tracks with the same channel will only recognise the MIDI input for recording on the lowest numbered track. Track 1 is the lowest on the grid layout, Track 8 is the upper row.
- With MIDI filtering enabled, any external MIDI controller set for the tracks channel can send data to this track as long as the track is selected.
- Each track can be reset independently to start from the beginning when recording.

## 4.13 Managing Patterns

Patterns can be saved and loaded and the convention in these menus is that knob 1 navigates projects and knob 2 patterns. Each sequencer will operate with one pattern at a time, and the previously active project will be loaded automatically when powered up. In these menus, pressing [Back] anytime will backup, cancel, or exit.

### ► Opening a Pattern in the Current Project

1. Open the load browser menu. Tap [Load] button. Hold to view temporarily.
2. The display will show the 16 available pattern slots for the currently selected sequencer and will label the currently active pattern as 'Loaded'. The grid will display 1-16 patterns across the columns. Rows represent each sequencers patterns.
3. Scroll to navigate the list. Turn (Knob 2). A ► symbol on the left of the list indicates the selected slot currently in focus. Knob 2 represents patterns, knob 1 projects.
4. Load from the selected slot. Press (Knob 2). The sub-menu 'Load Pattern' is displayed. Press (Knob 2) again to confirm and to load the project.
5. Alternatively, select a pattern directly using the grid. Tap a [Pad] for the sequencer to select. The 16 patterns pre sequencer are represented by pad rows. Brightly lit pads represent existing patterns for each sequencer. Tap a pad to load a pattern, this is instant if the sequencer is stopped. If running the change is made in line with pattern quantization. A 'PATTERN LOADED' message is displayed. Double tap a pad to open the sequencer view.
6. You can also quickly reload the current pattern from its previously saved state. Hold [Shift] + [Load] to reload the pattern.

#### Load / Save Grid View

In either the load or save menu, the grid represents the pattern slots per sequencer for the selected project. The load and save will timeout and revert to the default view after a short period. Diagram shows sequencer 1 selected, pattern 1 loaded.

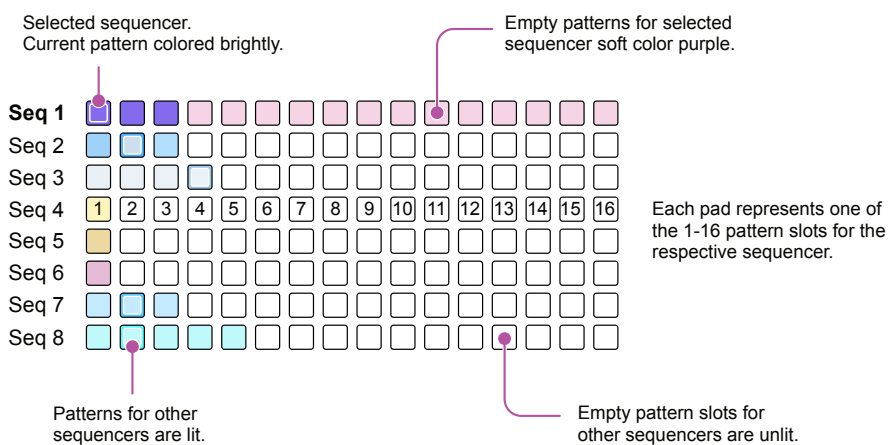

Load: Tap a pad to load a pattern from the slot for the selected sequencer. Load page.



Save: Double tap a pad slot to save the pattern for the selected sequencer. Save page.

## ► Opening All Patterns for the Sequencers in a Pad Column

1. Open the load browser menu. Tap [Load] button. Hold to view temporarily.
2. Using the grid pads, Hold [Shift] + Tap a [Pad] for the sequencer pattern to select along with all other sequencer patterns in the same column.
3. All pads will be brightly lit to indicate the patterns are selected for the respective sequencer.

## ► Opening a Pattern from Another Project

1. Open the load browser menu. Press [Load] button. Hold to view temporarily.
2. The display will show the 16 available pattern slots for the currently selected sequencer and will label the currently active pattern as 'Loaded'. The grid will display the patterns per row in line with each sequencer.
3. Scroll to navigate the project list. Turn (Knob 1) to select the source project. A ► symbol on the left of the list indicates the slot currently in focus. Knob 1 represents projects.
4. Scroll to navigate the pattern list for the previously highlighted project. Turn (Knob 2). A ► symbol on the left of the list indicates the selected slot currently in focus. Knob 2 represents patterns while knob 1 will only select projects.
5. Load from the selected slot. Press (Knob 2). The sub-menu 'Load Pattern' is displayed. Press (Knob 2) again to confirm and to load the pattern.
6. Alternatively, select a pattern directly using the grid. The grid will always show the project highlighted in the project load menu.

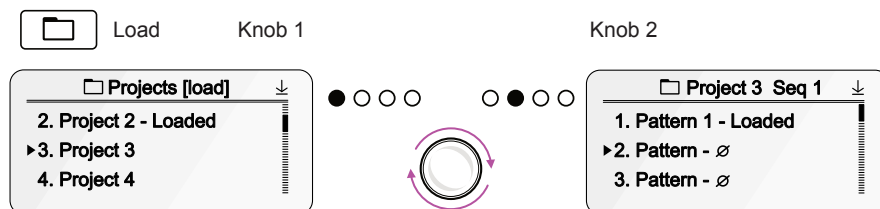

Turn to navigate a slot and tap to select load.

### ► Saving a Pattern

1. Open the save browser menu. Press [Save] button. Hold to view temporarily.
2. The display will show the 16 available pattern slots and will label the currently active project as 'Loaded'. The grid will also reflect the available patterns.
3. Scroll to navigate the list. Turn (Knob 2). A ► symbol on the left of the list indicates the selected slot currently in focus.
4. Save to the selected slot. Press (Knob 2). The sub-menu 'Save Pattern' is displayed along with the alternate options to rename, save as template or to clear. Ensure 'Save pattern' is selected. Press (Knob 2) again to save the pattern.
5. Alternatively, to save a pattern directly using the grid. Quickly double tap the [Pad] for the sequencer to save. Each of the 16 patterns is represented by a pad column. Brightly lit pads represent existing patterns for each sequencer. A 'PATTERN SAVED / PROJ UPDATED' message is displayed.

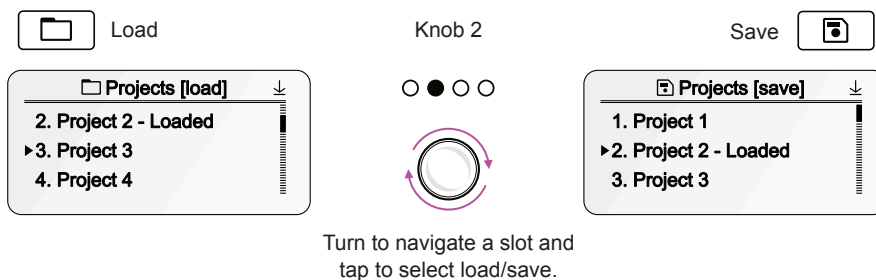

### ► Saving a Copy of the Current Pattern

1. Open the save browser. Press [Save] button.
2. The display will show the available pattern slots and will label the currently active pattern as 'Loaded'. The grid will also reflect the available patterns.
3. Scroll to navigate the list. Turn (Knob 2). A ► symbol on the left of the list indicates the selected slot currently in focus. Select a destination pattern slot to copy the current pattern to. This must be a different slot to the currently active pattern.
4. Save to the selected slot. Press (Knob 2). The sub-menu 'Save patt here as copy' is displayed. Select this option and press (Knob 2) again to save the pattern. A 'PATTERN SAVED / PROJECT UPDATED' message is displayed.

— Note —

To increase the performance and speed of saving patterns, any unchanged or empty patterns at the time of a save command are skipped. Only patterns that have been changed are saved.

**► Erasing a Pattern**

1. Open the save browser menu. Press [Save] button.
2. The display will show the 16 available pattern slots and will label the currently active pattern as 'Loaded'.
3. Scroll to navigate to the pattern to clear. Turn (Knob 2). A ► symbol on the left of the list indicates the selected slot.
4. Open the sub-menu for the selected pattern. Press (Knob 2). Ensure 'Clear pattern' is selected by turning (Knob 2). Press (Knob 2) again to clear the selected pattern.
5. Alternatively, hold [Shift] + [Clear] + Pad for pattern to delete.
6. A 'PROJ UPDATED' message will appear when clear is complete. The pattern is completely removed from the project.

---

**Note**

Loading and saving does not interrupt a playing pattern. Some functions however do create a short milliseconds delay when in use and can affect playback performance. These commands are indicated by the ⌚ symbol found in several menus

---

## 4 Creating Patterns

The save menu also offers options to rename or clear a current pattern. These options are found in the save confirmation sub-menu.

### ► Renaming a Pattern

1. Open the save browser menu. Press [Save] button.
2. The display will show the 16 available pattern slots and will label the currently active pattern as 'Loaded'.
3. Scroll to navigate to the active pattern. Turn (Knob 2). A ► symbol on the left of the list indicates the selected slot. Set to the 'Loaded' slot or any desired slot name to edit.
4. Open the sub-menu for the currently loaded pattern. Press (Knob 2). Ensure 'Rename' is selected by turning (Knob 2). Press (Knob 2) again to open the naming editor.
5. In the editor:
  - Knob 1 - Turn to scroll the selection of the alpha-numeric options. Tap to change the character.
  - Knob 2 - Turn to move the edit cursor in the text body being edited. Tap to backspace and clear the previous character.
  - Knob 3 - Press to cancel and return to the sub-menu.
  - Knob 4 - Press to confirm editing and complete the renaming.
6. Press [Back] at anytime to backup, cancel or exit.

Rename option found in the save sub-menu

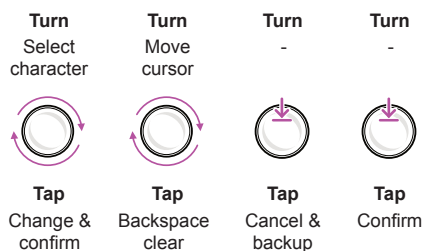
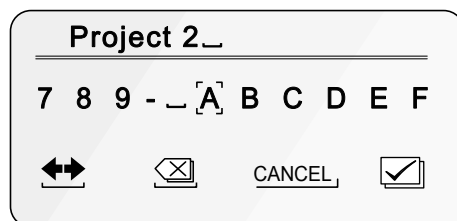

## 4.14 Pattern Templates

Pattern templates can be created from existing patterns and will save settings such as MIDI Channel, CC, Scale etc. This allows templates to be created for different gear setups and then loaded as a starting point to a sequencer to get started. Any of the eight existing sequencer patterns can be saved as a template.

### ► Opening a Template

1. Select the destination sequencer, Press [1] - [8].
2. Open the load browser menu. Press [Load] button.
3. The display will show the 20 available project slots followed by the 'TEMPLATES' sub-menu. Scroll to navigate the list. Turn (Knob 1) to the templates option.
4. Open the templates list. Press (Knob 1). The templates sub-menu opens and a list of 32 template slots is presented.
5. Turn (Knob 1) to select the template to open. Press (Knob 1) to confirm selection. The 'Load template' menu option is displayed. Ensure this is highlighted,
6. Press (Knob 1) to select the template highlighted. A 'TEMPLATE LOADED' message is displayed and the display returns to the main project menu. The selected sequencer will now be prepared with the pattern and settings as a starting point.

### ► Saving the Current Pattern as a Template

1. Ensure the sequencer and pattern is selected that will form the basis of the saved template.
2. Open the save browser menu. Press [Save] button. Hold to view temporarily.
3. When scrolling with (Knob 1), the display will show the 20 available project slots followed by the 'TEMPLATES' sub-menu.
4. Scroll to navigate the list. Turn (Knob 1). A ► symbol on the left of the list indicates the selected project slot currently in focus to save. Choose 'TEMPLATES'.
5. Press (Knob 1) when highlighting 'TEMPLATES'.
6. Navigate to a template slot by turning (Knob 1). Press (Knob 1) to select.
7. The sub-menu 'Save as a template' is displayed along with the alternate rename option. Ensure 'Save as a template' is chosen.
8. Press (Knob 1) again to save the pattern template. A 'TEMPLATES UPDATED' message is displayed.

### ► Saving Pattern as a Template (alternate option)

1. Open the save browser menu. Press [Save] button. Hold to view temporarily.
2. Turning (Knob 2), the display will show the 16 available pattern slots and will label the currently active pattern as 'Loaded'.
3. Scroll to navigate the list. Turn (Knob 2). A ► symbol on the left of the list indicates the selected slot currently in focus to save. Select the existing 'Loaded' pattern to save as a template.
4. Press (Knob 2). The sub-menu opens, Turn (Knob 2) to select 'Save as template'.
5. Press (Knob 2) to save to a template slot. Navigate to the slot to save to by turning (Knob 2).
6. Once highlighted with the cursor, Press (Knob 2). Confirm Yes or No. Select 'Yes' and press (Knob 2) again. Alternatively select no to cancel. A 'TEMPLATES UPDATED' message is displayed.

### ► Renaming a Template

1. Open the save browser menu. Press [Save] button.
2. Turn (Knob 1) to display will show the 20 available project slots. Navigate to the 'TEMPLATES' option and press (Knob 1).
3. Scroll to navigate to the template to rename. Turn (Knob 1). A ► symbol on the left of the list indicates the selected slot. Press (Knob 1) to confirm.
4. The 'Rename template' menu option should be selected. Turn (Knob 1) to choose. Press (Knob 1) again to open the naming editor.
5. In the editor:
  - Knob 1 - Turn to scroll the selection of the alpha-numeric options. Tap to change the character.
  - Knob 2 - Turn to move the edit cursor in the text body being edited. Tap to backspace and clear the previous character.
  - Knob 3 - Press to cancel and return to the sub-menu.
  - Knob 4 - Press to confirm editing and complete the renaming.
6. Press [Back] at anytime to backup, cancel or exit.





# Performance Tools

A set of tools and helpful features are available that operate globally across many of OXI ONE's modes and functions. It makes sense to get to know these tools before diving deeper into the sequencer modes, as many of them will be helpful to know when working within these modes. Of course, several other tools are more associated with specific modes and operate only in certain environments and settings. These exclusive tools will be explained alongside the sequencer modes in the next section. This chapter will help to differentiate between the tools integrated into the sequencer modes, described later, and those that can operate as stand-alone production or performance tools yet still serve all of the sequencers. Some functions add to the workflow to speed it up or simplify the production process, while others enhance the live performance experience; most do both. Some examples of these performance tools include the grid keyboard. This feature allows the grid to be presented and played in a piano style keyboard, either chromatically or based on other scales. The internal keyboard can provide input to sequencers or help to create live ad-libs and improvisations. Also, flow selectively triggers (or not) certain events on the fly, and roller is a simple creative tool that can work in many of the available modes. You can read this section in-depth or scan through it to be aware of what is available and refer back later. Either way, this section is a comprehensive guide to the global toolkit for developing songs further and performing them live.

# 5 Performance Tools

## 5.1 Keyboard View

Sequencer view is the normal 'home' view where the grid generally represents pitch and steps. However the grid can be switched to a keyboard view where columns represent notes and the rows represent the octave for each note. The exact layout is dependant on the scale selected and the current sequencer mode. Keyboard is presented in a classic style or in an isomorphic style or for multitrack mode, a drum pad style layout.

### Accessing the Keyboard View

**Select Keyboard view.**  
Tap [Keyboard].



Tap to select or hold to temporary view the keyboard.  
Keyboard button will be lit white in keyboard view.

**Classic View:** Default keyboard layout.

**Chromatic** scale shows 'white' keys in purple and 'black keys' unlit.

Base octave is independent from sequencer and can be adjusted between C-2 and C4

Columns 1-12 represent semitone intervals over an octave

**Other Scales**

All scales apart from chromatic show the notes that are not in the current scale as lit soft red.

**Roller.** Column 13 .  
Each row selects a time division for applying a roll.

**Isomorphic View:** Select either of these two options in the config > performance menu.

**Isomorphic 5<sup>th</sup> - Chromatic**

**Isomorphic 4<sup>th</sup> - Chromatic**

Base note is highlighted in all scales expect for chromatic

Isomorphic view displays a fixed interval between notes in the same column, laid out different to the normal musical convention. With the interval between notes being fixed it makes playing of chords a simple process.

### Keyboard Preview On/Off



+



Toggle on to audition any MIDI or CV outputs when placing notes on the piano roll grid.  
Button will be lit turquoise when on. When off, steps are placed silently.

It is possible to access a number of important and relevant parameters directly from keyboard view.

**Keyboard Options**

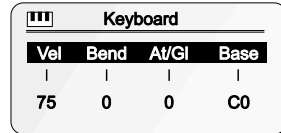

A set of default keyboard options are displayed when in keyboard view. These can be edited by the 4 knobs. Hold (Knob) to reset its value to the default setting.

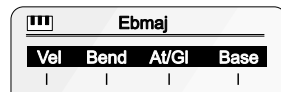

**Chord Recognition.** The chord will be identified and displayed in the keyboard while a chord is played in the header of the primary keyboard page.

Keyboard Parameters			
Vel	Bend	At/Gl	Base
Velocity	Manual Pitch Bend	Aftertouch / Pressure	Base Note
Velocity value of each note played on the keyboard. Range 1-127, default 75.	Performs a dynamic pitch bend for notes played. Range -128 to 127, default is 0.	Controls the output for aftertouch or pressure / glide. Glide is CV only. Range 0-127, default 0.	Base note for keyboard. Independent from sequencer. Located at the bottom grid row.

**Access to Main Secondary Options**

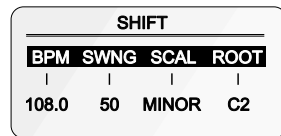

The global secondary parameters are accessible directly within the keyboard view by holding shift and turning a knob.

**Poly & Chord Mode - User Chords.**

The Chord and Poly keyboard views both offer the option to store user chords or notes into a set of pads. These are located in the top row, first 12 columns. To store a note or chord, hold the notes then hold the user chord pad. Full details are covered in the Poly and Chord mode descriptions.

## 5.2 Looping Patterns

**MO PO MT CH SC**

The overall pattern is configured with start and end points which determine the entire pattern length. In addition a loop can be set to play within the pattern that operates on a continuous cycle with its own defined start and end points.

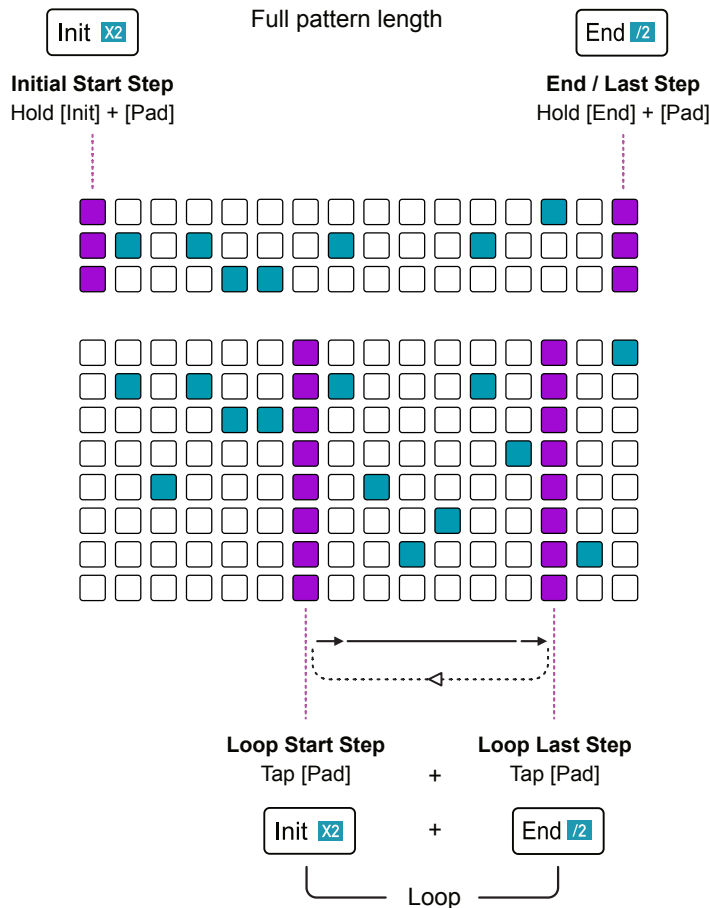

- Select loop view**      **Init x2** + **End /2**      Press both [Init] + [End] to select loop view. Both buttons will be lit in loop view.
- Select loop points**      +      Press both start [Pad] + end [Pad] together to select loop start and end. Loop points are indicated in loop view by purple lit columns.

+
- Loop over 1 step**           Press both start [Pad] + end [Pad] in the same column but on different rows.

The Init and End buttons will flash when a loop is set.
- Clear loop points**      **Init x2** or **End /2**      Press [Init] or [End] to deselect loop points. Both buttons will be lit to indicate loop view is still selected.

The loop will be released based on the 'loop sync release' setting. This is found in Config > Performance options. No Sync, Bar or Beat are the options.

The pattern will play continuously within the loop range when in a loop. A number of loop settings are also available in the loop for each sequencer. Loops can be set for each sequencer, in multitrack mode this is for each track.

Loops can be edited while playing a pattern. Transposing the pattern or editing steps can still be performed if a loop is active.

**Loop View**

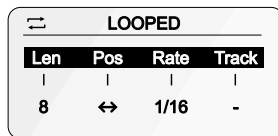

The settings apply to the selected sequencer when loop is on and a loop is set.

Loop Options			
Len	Pos	Rate	Track
Length intervals	Loop position	Individual loop speed	Multitrack track to edit
Doubles or halves the loop length from the current start. If no loop exists, a new loop is created when editing.	Shifts the entire loop in 1 step increments forwards or backwards. Hold [Shift] to move in increments equivalent to the current loop length.	Rate or division of the playhead when playing in the current loop.	Selects track 1-8 to edit individually or edit all simultaneously. These only apply to tracks in multitrack mode.

**Snapshots & Loops**

Snapshots and loops can operate together in a complimentary way. This can add to the creativity. The snapshot and loop logic follows:-

- Loops can be used in snapshots.
- Snapshots can be used within loops.
- Exiting a snapshot will also exit the loop.
- Exiting a loop does not exit the snapshot.

---

— Note —  
 Loop view is available in all sequencer modes with exception of Matriceal mode. The loop option is not available in this mode

---

# 5 Performance Tools

## 5.3 Arpeggiators

MO PO MT CH SC MC PZ PY LR

An arpeggiator or arp is a function that is described as playing ‘broken notes.’ Instead of playing multiple notes simultaneously as a chord, an arp separates and sequences each note into a looped pattern or musical phrase called arpeggios. In ONE, think of this as a sequence within a sequence.

Arp is linked to the grid keyboard and when accessing [Arp], the keyboard view will open automatically. In addition to the keyboard arp, poly and chord modes also have a dedicated arpeggiator which use the notes on the grid as the source from which to create an arpeggio. Access to the poly and chord arp is made using the [Arp] button in each sequencer grid view.

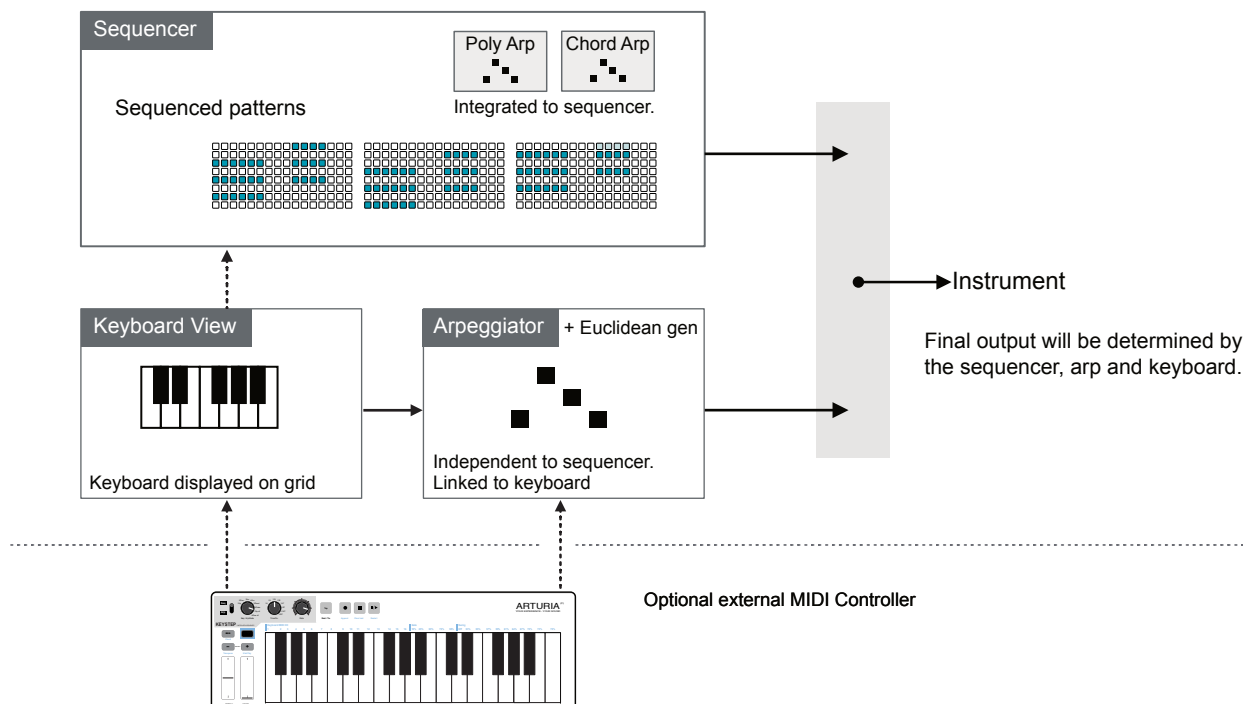

### Navigating the Arp Settings

#### Select the Arp Options.

Tap [Arp].



Tap to select or hold to temporary view the arp options. Button is lit when arp ‘type’ is on and is unlit when arp is off.



In mono, multitrack, stochastic, matriceal modes the keyboard arp is used and keyboard view will open automatically. Poly and chord mode must be in sequencer grid view for the sequencer arp and keyboard mode for keyboard arp.

Type	Octv	Gate	Div
ON	0	50	1/16
Accnt	Len	Puls	Rept
+0%	16	16	0



Quickly tap (Knob) of the respective parameter to toggle between selecting the upper or lower parameter for editing.

GTIm	Grov	Reset	Latch
0%	Grv 1	OFF	OFF



Tap [Page] button to select between arpeggiator pages. Page button flashes when additional pages are available.

## Editing & Controlling the Arp



Turn (Type) knob 1 in arp page 1 to turn the arpeggiator type on or off. Once set to on, quickly change on/off by, holding [Shift] + tap (Type), knob 1.



In keyboard view, the [Arp] button will flash if the type is set to 'On' and the arp page is not on display. If arp is on display, button is lit. Arp settings are retained when toggling the arp on and off.



Type: Off



unlit

Keyboard View On

Type: On.  
Arp page in view.



lit

Type: On.  
Arp page not displayed.



flash



Turn (Knob) of the respective parameter to adjust its value. Tap the (Knob) to switch between upper and lower parameters. To reset any of the parameters, Hold (Knob) > 2 secs for the respective parameter.



Press [Play] to play sequencer. Play must be on in order for an arp to work irrespective of whether the sequencer is active or not.



Press [Rec] to record the arpeggio into the sequencer. The global keyboard arp will also captures velocity and groove. Does not apply to chord arp which cannot be recorded.



**Hold function.** Hold [Shift] + Tap [Arp] to toggle hold on or off. Hold will retain or remove notes added on the keyboard and not require them to be manually held when played. Hold - button turquoise.

Held notes are retained when exiting the keyboard view or when the sequencer is changed. Use in conjunction with 'latch' on page 2 to add and retain multiple notes incrementally.

## Creative tips for Arpeggios

- Consider layering arps using the 8 sequencers to build complex and generative passages and songs. The 'hold' feature is useful here.
- Modulation and LFO's can be applied to arp parameters opening up a whole new dimension of creativity. Experiment and try things out.
- Remember the flow, probability and logic features can also expand the arp flexibility even more.
- Try changing the reset to differentiate pattern position or groove reset.

– Note

The workflow and parameter controls are designed for easy access and quick, creative control when working in an arpeggiator environment. They may therefore differ slightly to the standard ONE control conventions.

## 5 Performance Tools

The ONE arpeggiator is an advanced tool for creating interesting melodies and phrases. The arp can appear complex so taking a little time in this section will help to get a better understanding.

The OXI ONE arp consists of two components that work together to generate the output phrase. Firstly is the arpeggiator core engine, this is the component that converts a chord to sequenced notes, assigns the playback order, speed and velocity profile. In addition a Euclidean generator applies further manipulation of the arp generated notes. The Euclidean elements consist of length, pulse and repeats and contribute to the output phrase by adjusting the note sequence and timing to create interesting rhythms.

Arpeggiator Parameters			Page 1/2
Type	OctV	Gate	Div
Off / On - Arpeggio algorithm	Octave voicing range	Gate length	Note timing division
When on, sets the arp direction and style for the musical phrase. Also can be set to off.	Introduces a number of higher or lower octave notes, into the arpeggio. Range is -7 to +7.	Length of the arp note gate between 2-100 based on 'Div' time division. The default is 50.	Sets the arp specific note intervals. This can be different to the sequencer.
Accnt	Leng	Puls	Rept
Velocity Accent	Euclidean phrase length	Euclidean phrase pulses	Euclidean pulse repeats
Varies the arp note velocity in a pattern from a selected 'Groove' groove template selected. Range -100 to +100%	Sets the total length of the Euclidean phrase. Range is 1-32, default is 16.	Number of pulses in the Euclidean generator. Range is 1-32, default is 16.	Generates repeats for pulses in the Euclidean generator. Range is 0-16, default is 0.

Groove accent and arp integrated, Euclidean generator parameters

Arpeggio Additional Parameters			Page 2/2
Gtime	Grov	Reset	Latch
Timing of the groove	Groove Templates	Reset	Keyboard Latch notes selection
Adjusts the velocity timing of the arp notes within the selected groove.	Selects a groove template. These are applied to the arpeggio timing and velocity.	Resets the arp pattern position, groove, all or none to start at the beginning when new arp notes are applied. *	Works in conjunction with the keyboard hold. Multiple notes can be selected and locked on.

\* Arp pattern reset on note change is also available in the config > performance settings.

Groov - Groove Templates	
Number	Name
Grv 1	Trancey Groove 16th
Grv 2	Disco Light Swing 16
Grv 3	Tambourin 16th
Grv 4	Bomba Acc 16th
Grv 5	Shaker ChaCha 16th
Grv 6	Loosely Flow 16th
Grv 7	Claves Accent 16th

Number	Name
8	Caixa Accent 16th
9	Charanga Shaker 16th
10	Dancehall 16th
11	Disco Indie 16th
12	Fusion Tight 16
13	African Timbales 16
14	Quinta Loca 16th

To apply a standard swing, use Groove 1 and adjust the Gtime parameter accordingly. Groove may apply a velocity profile to the arpeggio or affect note timing or both.

User groove profiles can be created externally as well as in the OXI App and loaded to ONE.

### Deconstructing the Arpeggiator

These examples show the behavior of the arpeggiator and the affect that some of the key settings have on the arpeggiated output. The ONE arpeggiator is an advanced tool featuring traditional arp functions, Euclidean pulses and groove templates. It is a great example of how the internal ONE ecosystem brings together features for more creativity and musical inspiration.

Scale: Chromatic Root C2, Chord C Major

Chord - C Major played on the keyboard grid

#### Hold & Latch

The keyboard arp takes notes from those played, held or latched onto the keyboard. Hold is selected with [Shift] + [Arp]. Held notes are latched, but are released when selecting another note. Notes can be held simultaneously. Latching notes is an option available in the arp page 2/2 and maintains any notes selected incrementally. The sequencer must be playing to select and latch notes on the keyboard.

Chromatic Keyboard

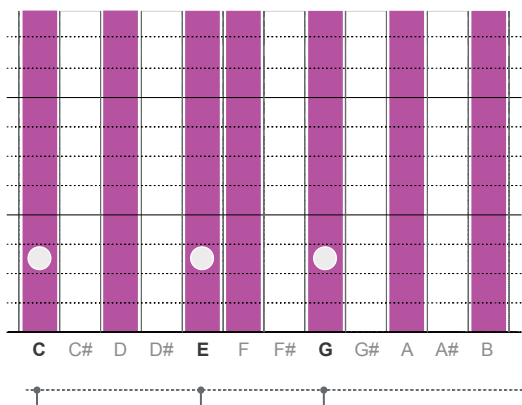

Arp breaks chord into discrete notes

The arpeggio can extend beyond the current octave.

**Gate.** Percentage of the note gate determines length with respect to the time division.

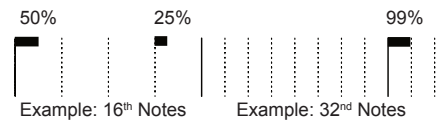

**Div.** Divisions for the arpeggio, independent of the sequencer time intervals.

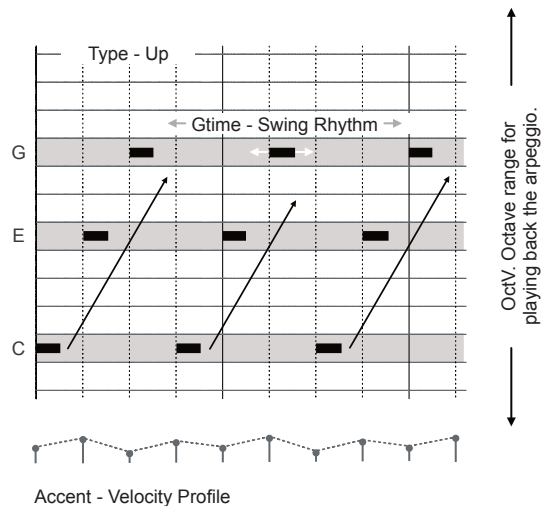

### Groove Engine

**Accnt.** The accent option sets the amount of velocity profile that is applied to the arpeggio. The profile is based on the template selected in the **Grov** option and creates a soft or emphasised musical groove. This groove is based on velocity deviations through the arpeggio.

**GTime.** In addition to velocity creating a rhythmic texture, Gtim can also apply a swing style groove to offset the micro timing of some notes. A range of +/-100% controls the amount. This rhythmic style is taken from the selected template chosen from the **Grov** options.

### Reset

The reset behavior of the arpeggiator when new arp notes are applied can be set. The **Reset** parameter is found in page 2 of the arp parameters edited with (Knob 3). The pattern position, 'aPos' can be reset only, Groove, 'Grve' only or 'All', resetting both groove and arp pattern position. Reset can also be set to off, allowing it to freely run.

## 5 Performance Tools

**Type.** Type sets the arpeggiator on or off, and if on, selects one of twelve algorithms. The active algorithm is displayed in the arp page header. This generally controls the direction and pattern behavior of the generated arpeggio notes. The arpeggio loops based on notes selected.

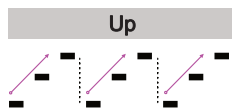

Notes are played lowest first and incrementally up the scale across the octaves selected then back to the lowest note in the selected range. Example has 3 notes.

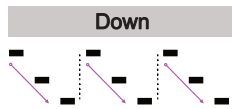

Notes are played highest first and incrementally down the scale across the octaves selected then back to the highest note in the selected range. Example has 3 notes.

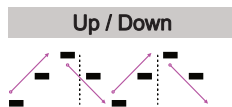

Notes are played lowest first and incrementally up the scale across the octaves selected then back down the range. Loops through this cycle continuously. Example has 3 notes.

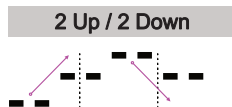

Notes are doubled up at the arp time intervals and play lowest first, then up the scale and the octaves selected then, back down the range. Loops this cycle continuously. Example has 3 notes.

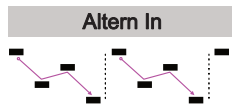

Notes alternative in sequence starting from the upper notes and working downwards in a 'zig-zag' style then back to restart at the upper note. Example has 4 notes.

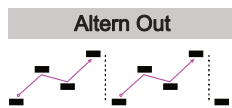

Notes alternative in sequence starting from the lower notes and working upwards in a 'zig-zag' style then back to restart at the lower note. Example has 4 notes.



Notes alternative in sequence starting from the upper note then lower note before working inwards in a 'zig-zag' style then back to restart at the upper note. Example has 4 notes.

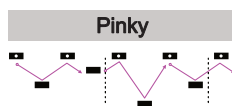

Notes are generated based on the upper note as the 'anchor' reference, with all other notes alternating in turn with the upper note. Example has 4 notes.

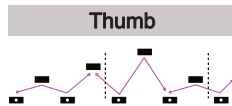

Notes are generated based on the lower note as the 'anchor' reference, with all other notes alternating in turn with the lower note. Example has 4 notes.



Notes are generated randomly throughout the arpeggio and change in an evolving, but unpredictable way. Example has 4 notes.



Notes are generated randomly throughout the initial arpeggio cycle and then remain in the same pattern for the arpeggio cycles. Example has 4 notes.

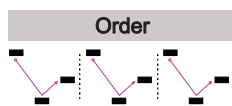

Notes are played in the arpeggio in the order that they are played on the keyboard. Example has 3 notes.

In addition to the standard arpeggiator function which generates pitch based arpeggios, the ONE arp also has integrated Euclidean rhythm generator which creates more interesting grooves and musical passages. The Euclidean generator operates on the timing of the arp generated notes adding a more complex layer of pattern generation.

A Euclidean pattern is one generated using a mathematical formula for note placement and timing. In simple terms, a number of pulses are generated at equally spaced intervals within a defined length. Think of the ONE arp generating an initial arpeggiated pattern with the Euclidean generator optionally adding more manipulation of note timing and developing the rhythm even further.

### Euclidean concepts

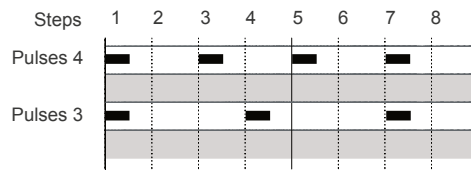

#### Steps

A Euclidean generator needs a time duration, typically beats in the time interval. This can be set in steps to determine the overall length to operate within. Example 8.

#### Pulses

Pulses are the actual triggers within the time period that generate notes. A Euclidean generator takes the selected number of pulses and distributed them as evenly as possible across the time period.

### ONE Euclidean generator

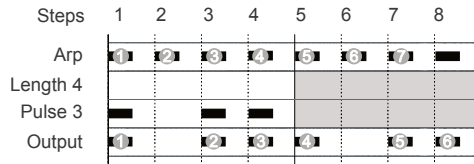

#### Length

Length determines the number of steps in the overall Euclidean phrase. This can be selected from a range of 1-32, default is 16. This is based on the arp step intervals. Example shows length of 4 steps.

#### Pulses

Pulses are the step triggers distributed within the length. The options are between 1-32 to fit the available length range, default 16. The source of pulses comes from the notes in the arpeggio handled in batches set by length. Example above shows 3 pulses, repeat set to 0.

In essence the actual output of the arp will be the arpeggiated notes further affected by the groove and Euclidean generators. So with length and pulse set to the same number, the output will be a pure arpeggio with no Euclidean affect applied, for example defaults are both length and pulse set to 16.



#### Repeats

There is an additional Rept option that can be adjusted between 0-16 with default at 0. This feature selects how many repeats are added to a Euclidean pulse and works in conjunction with the other Euclidean settings. This may not be easily recognised where a high number of pulses are already generated or the length is set low. A good example in use is with a repeat of 0, length of 16 and 1 pulse, one note will be generated into the 16 step phrase. If repeat is set to 8 it will place 8 additional notes after the original pulse, a total of 9 notes in the arp pattern.

### 5.4 Flow

Is flow a tool or a button? Well it's both. The general concept is that flow is a feature that enables specific events and actions to be configured to only operate under a certain condition. That condition being linked to the status of the flow button. For example, notes can be sequenced to play but only while the flow button is pressed, otherwise these notes do not play in the pattern.

Flow  Events can be set to operate based on the flow button condition. Any 'flow' assigned functions will only operate when the [Flow] button is held.

Flow Step  +  Hold [Flow] + tap [Pad] to add a 'flow' step. Steps will only be triggered in a playing pattern while the [Flow] button is held.

Flow can also be applied in various menus including the step menu options.

Flow can be configured at various points around the OXI ONE feature set. It is not an exclusive function only for note triggers. This makes flow a powerful feature, especially for live performances and improvised sessions.

An example is the mono mode accumulator. The Acm% parameter in the step options also has Flow and Flow available. This allows the accumulator to operate, or not, with control from the [Flow] button.

Generally speaking, flow is a parameter found within the probability options of a function

**Example: Note events set using the step menu**

Notes sequenced in a pattern will all normally play when notes are triggered. Trig default is 100%, applied to all notes.



► Play

Stp 2	J D2	1/3
Vel	Oct	Gate
75	+0	50

Stp 2	J D2	1/3
Vel	Oct	Gate
75	+0	50

Hold Step



Turn (Trig)

Notes sequenced in a pattern. Some trig settings set to 'Flow'. Trig default at 100%, applied to other notes.



Normal playback will play all notes except those with a flow trig set.

► Play



With [Flow] held, all notes including flow trig notes play. If [Flow] is not held, flow notes do not play

► Play

Notes sequenced in a pattern. Some trig settings set to 'Not Flow', ie  $\overline{\text{FLOW}}$ . Trig default at 100%, applied to other notes.



If [Flow] is not held, all notes play. With [Flow] held, notes set to 'Not Flow' wont play.

► Play

Flow configured events are activated when the [Flow] button is held. The 'not flow' option works in the opposite way.  $\overline{\text{Flow}}$  configured events are not activated when the [Flow] button is held.

# 5 Performance Tools

## 5.5 Roller

MO PO MT SC MC

Roller is a tool for mono, poly, multitrack, matriceal and stochastic modes which triggers a pattern roll at defined note intervals. The roller is located in keyboard view and controlled with column 13 in the grid where each pad triggers a note interval. Arp should be off and notes played on the keyboard with the transport playing.

### Keyboard View

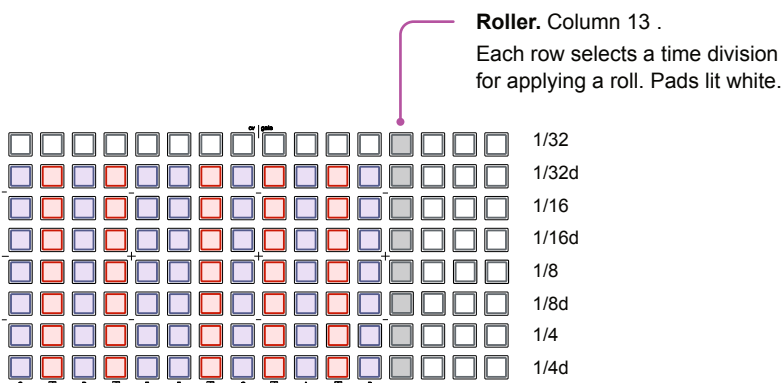

### Notes. Lit Purple

While holding a note or chord, pressing a roller pad will trigger a series of notes at the interval selected.

### Editing & Controlling Roller



Off



On

Tap [Pad] in column 13 to toggle roller time interval ON, button is brightly lit. When inactive button is dimly lit white.



The transport must be playing for roller to be used. Play any note using the grid keyboard to play a roller note.



Hold [Shift] + Tap [Arp] to toggle 'hold' on or off. Hold will retain any notes played simultaneously on the keyboard. Notes are not required to be continuously pressed. Held pads will flash.

### Example



Notes and chords held on the grid keyboard. Played as normal



Notes and chords held on the grid keyboard. Roller with pad 1/16 set to On.

## 5.6 Random Perform

OXI ONE can create random variations to existing patterns on the fly, ideal for performing live, improvisation, experimentation or just jamming. Random performance function is non-destructive, varying parameters and patterns temporarily while retaining the original pattern and its data integrity. Random perform is accessible directly by pressing [Randomizer]. Random pattern generation using the [Randomizer] is explained in an earlier chapter. In multitrack and matriceal modes random perform affects each of the tracks independently.

### Random Perform

The principle of the random perform is to introduce random rhythmic and melodic pattern variations while performing live or while playing out existing patterns. Parameters and settings that affect the pattern musically can be 'performed' like an instrument, affecting all steps in a selected track or sequencer. The process allows for experimentation and exploration by temporarily or periodically varying parameters from their original position while being able to restore original sequence settings.

Random perform menu



Quick Tap [Randomizer] to open the random perform menu page.  
Hold [Randomizer] to temporarily display the menu, exiting on release.

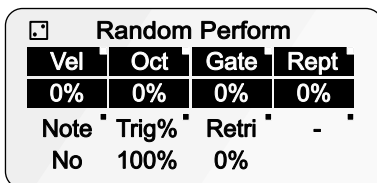

Randomizer - Perform Page

Parameters set are variations from the original value and timing is preserved. These can be adjusted to create variations on-the-fly or before playing. Hold a knob to reset its value. This is particularly important to restore the original setting.

Random Perform Parameters			
Vel	Oct	Gate	Rept
Random velocity amount	Random octave amount	Random gate length	Repeat randomization
Sets the amount of random variation applied to the steps velocity. This can operate polar 0-100% or bipolar -100% to +100%. Default is 0%	Sets the probability and range for the octave variation. This can operate polar 0-100% or bipolar -100% to +100%. Default is 0%	Sets the gate length variation. This can operate polar 0-100% or bipolar -100% to +100%.	Sets the amount of randomization for repeats triggered. 0-100%, default is 0%.
Note	Trig%	Retri	Scope
Note randomization	Velocity variation	Retrigger randomization *	Poly Mode Randomization
Sets the amount of random variation applied to the notes. This can operate polar 0-100% or bipolar -100% to +100%. Default is 0%	Sets the probability that notes will be played. 0 - 100%, default is 100%, all notes play, there is no randomization.	Sets the amount of randomization for retriggers and also affects skip. -100% to 100%, default is 0%.	Applied in the Poly sequencer mode only. Set randomization to apply per note or to the whole column.

\* The behaviour of 'Retr' also affects skips. Skips are added randomly when the 'Retri' value is negative. In the range 0-32% skips and some retriggered are converted to triggers randomly. Values above 33% to 100% increase probability of retriggers being applied and skips have even more chance of being triggered.

— Note —

Select the random generator [Randomizer]. In this mode, switch between the random generator and random perform pages by tapping [Randomizer] or using [Shift] + [Randomizer].

# 5 Performance Tools

## Random Performance in Multitrack Mode

**MT**

In multitrack mode the random perform function operates for each track. The tracks can be muted or unmuted for randomization. This doesn't mute the sequencer, but just mutes the randomization applied.

### Muting multitrack randomize perf

In the random perf function, hold the [Randomize] button + tap the multitrack grid column 1. The multitrack column 1 is a track selection function. Tapping each track while holding the randomize will mute the applied randomization, playing the original sequence or unmute randomization, applying the random perf variations.



In Random Perf, page displayed, Hold [Randomizer] + tap column 1 [Pad] to mute or unmute the randomization.

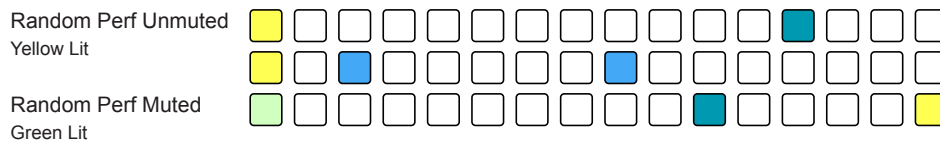

## Randomize Matriceal Matrices

**MC**

In matriceal mode the random perform option can be used for each tracks matrices. This will apply a random series of steps to the selected matrices. The 'Rnd' % by holding a step [Pad] + turning (Knob 4) will be applied with this function. The randomization can be undone.



Hold any [Pad] in the upper 16 pad lane section to select and tap [Randomizer].

OR



Hold any [Pad] in the upper 16 pad lane section to select and tap (Knob 4).

TRIGGER			
Len	Puls	Clr↓	Rnd↓
16	4	...	50%

The randomization amount set in the parameter page for knob 4 will be applied when using either randomization option..



Hold any [Pad] in the upper 16 pad lane section to select and turn (Knob 4) to adjust the randomization amount. Reflected in the number of steps applied.

## Randomize Poly Mode

**PO**

The 'Scope' parameter is available in random perform for the poly mode sequencer. Scope selects whether to randomize per note or the whole column. Column randomization is useful for rhythmic chords and repeats and these settings help tame the randomization to maintain the musicality.

### 5.7 Perform

OXI ONE has a unique and powerful performance tool, presenting the grid pad as a live performance or improvisation instrument. The performance view displays a representation of all assigned sequencers on the grid and allows the pads to be used to control the performance of the sequencers while playing. Sequencers can be muted, transposed and more depending on the mode.

**Select Perform**  
Select Mode



Tap [Perf] to open the performer grid.  
Hold [Perf] to temporarily select the grid. Perf will exit on button release.

Pads and grid zones represent performance controls based on the sequencer mode assigned. Each row therefore represents the sequencer and the pads control the specific performance feature. Pad colors represent the control and are not representative of the assigned sequencer color scheme.

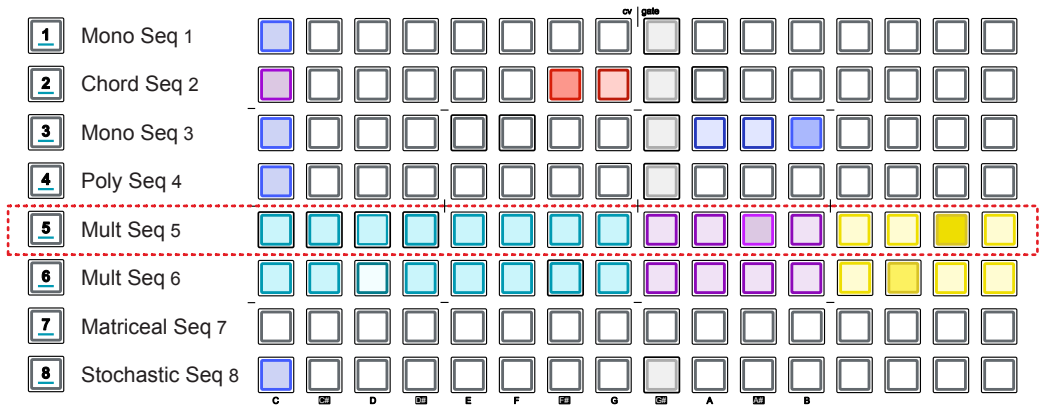

**Perform**  
Apply a variation



Press a [Pad] for the specific function on the row for the sequencer to control. Rows represents sequencers. Pad brightness or color represents active state

**Start / End**  
Seq Range



The [Init] and [End] functions can be used to edit a sequencer length while in the perform page. However edits only possible with the knobs and not the grid pads.

**Secondary Grid**  
Additional options



Holding shift will display the secondary grid which represents additional performance functions, should they exist.

Each function and its sequencer mode will be described individually to help with the understanding of the available options per sequencer. Remember, all 8 sequencers are represented collectively on the grid and this will change if the sequencer modes are changed.

# 5 Performance Tools

## Muting Sequencers

**MO PO MT CH SC MC DM PY SA**

Available with: Mono, Poly, Multi, Chord, Domino, Saga, MIDI Player, Stochastic, Matriceal

The first pad column for mono, poly, chord, domino, saga, MIDI Player and stochastic sequencer modes will mute or unmute the sequencer. Multitrack and matriceal use the first 8 or 4 columns as track mutes respectively. This centralises control which is important when using mutes as a performance function. For multitrack and matriceal sequencers, each track can be muted independently. Each track is therefore represented by a column.

Tap a pad to mute / unmute a sequencer or multi track or matriceal track.

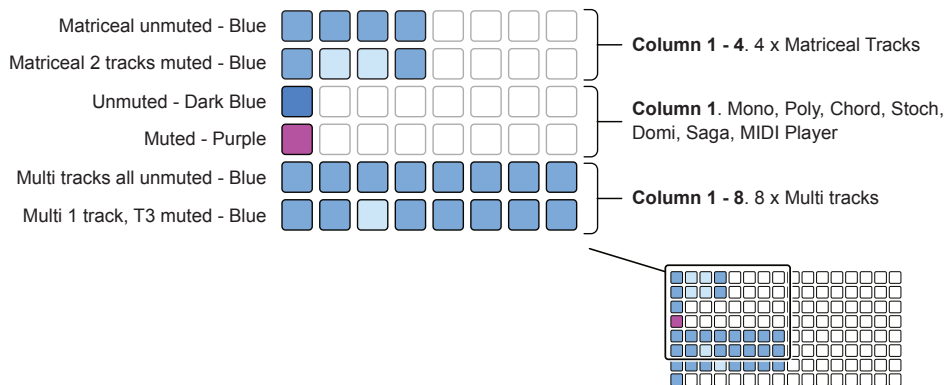

**Warning:** Performance mute states are retained when the per page is closed. Muted tracks and sequencers may not be visible in the other operating modes if muted in the performance page. Check the performance page mute states and other functions if the sequencer seems muted or playing out of pitch.

## Transposing a Sequencer

**MO PO CH SC DM PY SA**

Available with: Mono, Poly, Chord, Domino, Saga, MIDI Player and Stochastic

For all sequencer modes except multitrack and matriceal, the central pad group represents transposition of each sequencer. The white lit pad indicates the original setting, no transposition. Each pad to the right increments by 1 semitone and each pad to the left decrements by 1 semitone. Transposition is made within the currently selected scale notes.

Tap a pad transpose the sequencer.

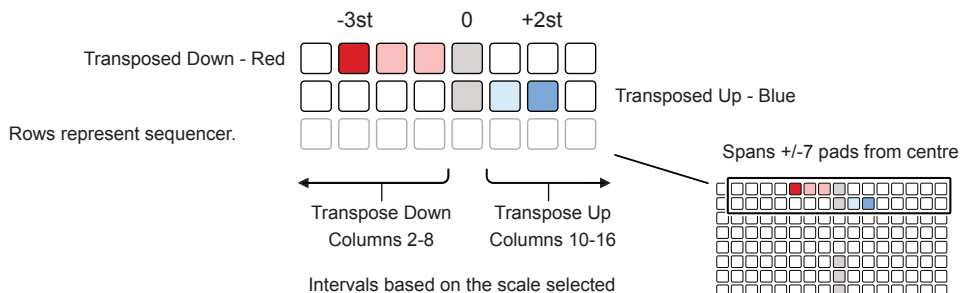

**Rotating a Sequencer**

**MO PO CH SC DM SA**

Available with: Mono, Poly, Chord, Domino, Saga, and Stochastic

For all sequencer modes except multitrack and matriceal, the sequencer can be shifted right or left in 1 step increments. The original position is shown with the yellow pad column. Access to the option for rotation is by holding [Shift] while editing pads.

**Secondary Grid**  
Rotate Option



Hold [Shift] + Tap a pad rotate the sequencer.

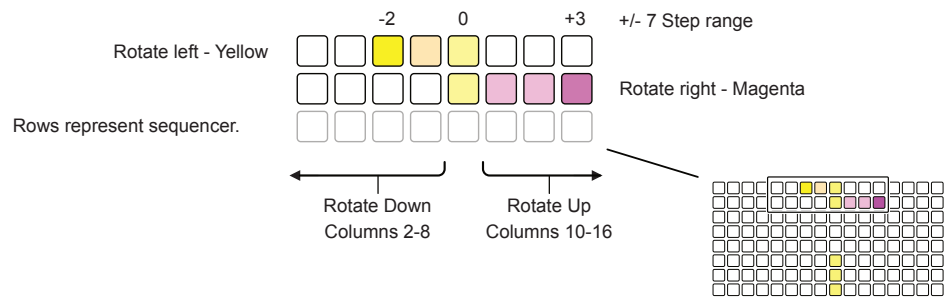

**Fills**

**MT MC**

Available with: Multitrack, Matriceal

The multitrack and matriceal have fills of varying intensity. Fills repeat notes at musical intervals based on the point of fill selection. Multi fills are located across columns 9-12 and matriceal's random trigger fills across columns 5-16.

Hold a pad to apply a fill.

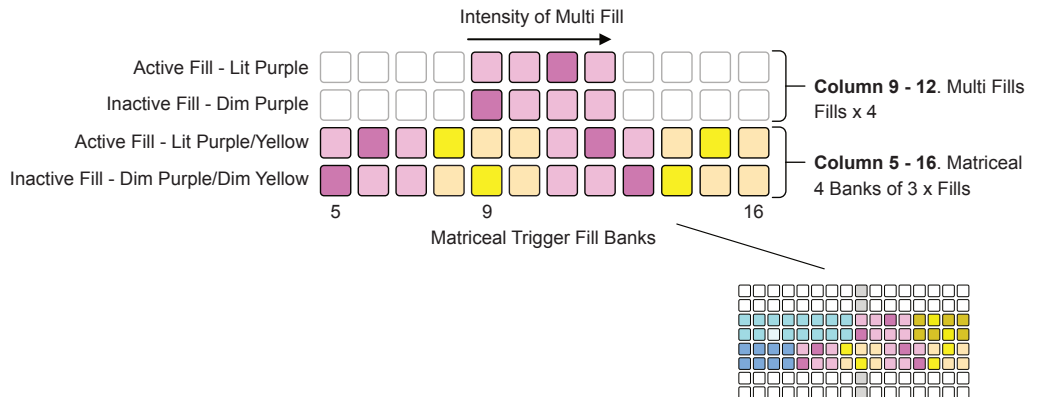

**Temporary Fill**



Simply hold a pad to apply a fill while held. Release the pad to release the fill.

**Latch Fill**



Use shift along with the pad to latch the fill on or off. Shift + Pad again to release the latch.

# 5 Performance Tools

## Loops



Available with: Multitrack

The final 4 pads capture and replay loops live while the sequencer plays. Each of the 4 pads captures a defined loop step length.

Hold a pad to apply a loop.

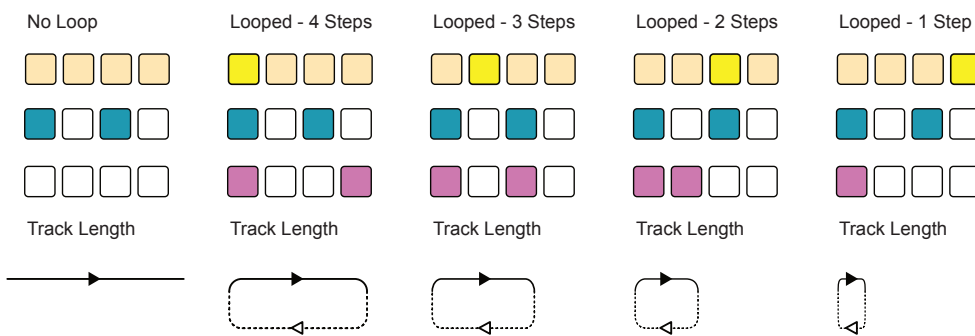
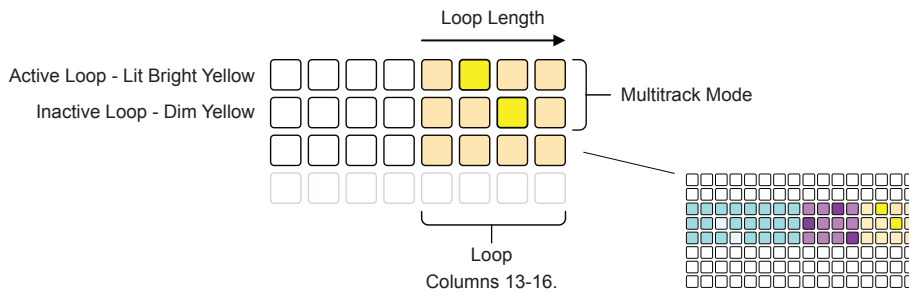

Loops are initially captured in running sequence at the point that the loop is selected. If changing the loop the length is adjusted within the existing loop range.

Release a selected loop pad to deselect. Exiting the loop will be based on the 'loop sync release' setting. This is found in Config > Performance options. No Sync, Bar or Beat are the options.

**Temporary Loop** Simply hold a pad to apply a loop while held. Release the pad to release the loop.

**Latch Loop** + Use shift along with the pad to latch the loop on or off. Shift + Pad again to release the latch.

**User Chords**

**CH PO**

Available with: Poly, Chord

User chord function is available for poly and chord. This allows chords created in a sequencer's keyboard mode to be accessible in the performance page. Chords can then be manually played to trigger in time with the pattern as it plays, replacing the current sequencer's notes with the chord. The options to latch the chords on hold or ignore / mute the sequencer are also available from this view.

**Performance Mode**



Hold [Perf] to select performance mode first.

**Poly chord view**



Hold [Perf] + Tap [1] - [8] for the Poly or Chord sequencer. Toggles chord view on or off.

The default performance grid view, used when the chord mode is off, uses the row pads to transpose the sequencer's pitch. When chord view is on, using [Perf] + Seq [1] - [8], the user chords are accessible in the orange lit pads.

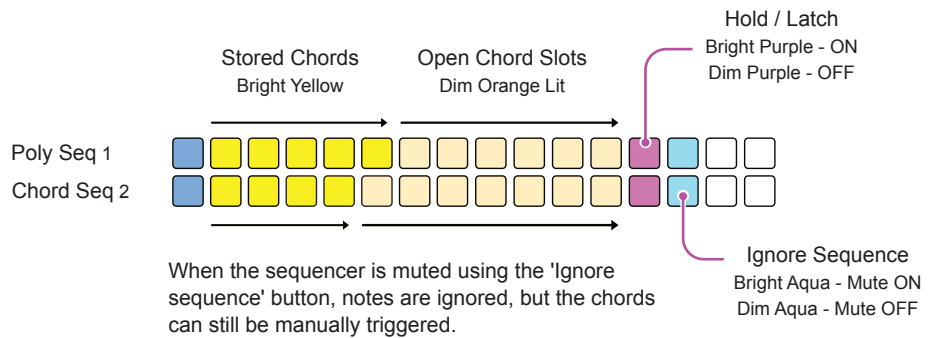

To play a chord in place of the existing pattern steps, hold the pad on the sequencer row for the stored chord to play. Only one chord can be played. If the hold mode is set to on, the chord will be latched on once pressed and the pad lit white. The chord is released if the pad is pressed again or hold is turned off.

# 5 Performance Tools

NOTES

## Quick Reference - Sequencer Mode Performance Rows

### Mono Mode

**MO**

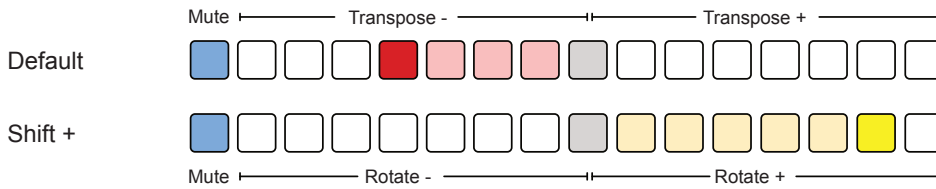

### Chord Mode

**CH**

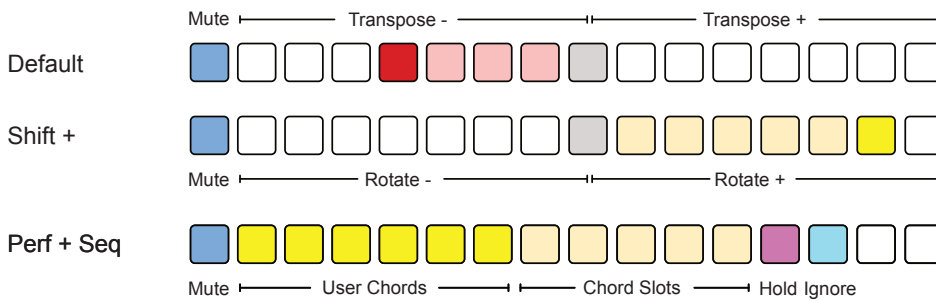

### Poly Mode

**PO**

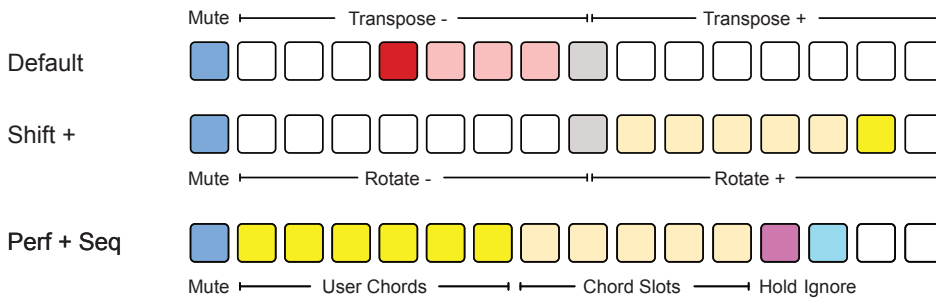

### Multitrack Mode

**MT**

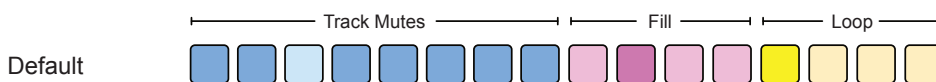

### Matriceal Mode

**MC**

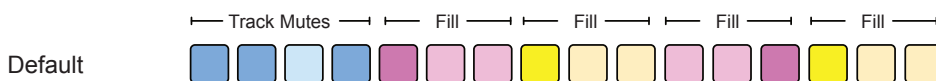

**Quick Reference - Sequencer Mode Performance Rows**

**Stochastic Mode**

**SC**

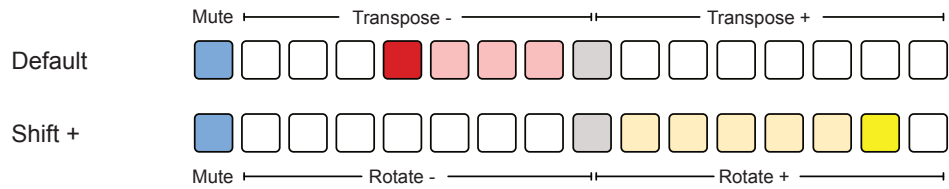

**Domino Mode**

**DM**

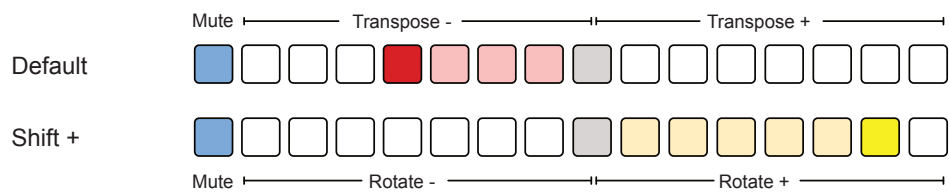

**Saga Mode**

**SA**

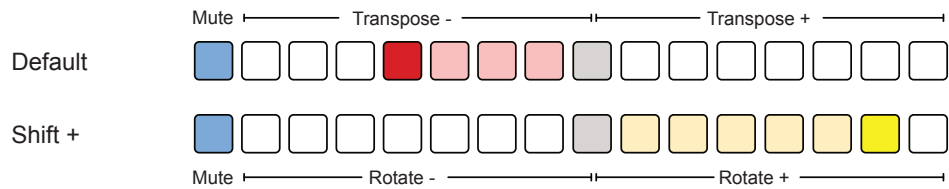

**MIDI Player Mode**

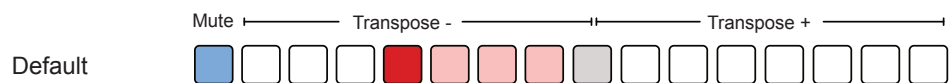

**PY**







# 5 Performance Tools

## 5.8 Snapshots

A snapshot is a tool which capture the state of all of the sequencers at a point in time and temporarily saves the sequencer settings, notes, mutes and modulation. This can then be recalled to restore the previous states of all of the sequencers. This is particularly useful in a live performance after making improvised or ad-lib changes and song deviations in order to return to the known, original state.

Capture Snapshot  +  Hold [Load] + press [Save] to capture a snapshot. Temporarily saves all sequencers, current states.

 Snapshot active

MONO 50%   INT 

105.0 Pattern 3



1/16 CHROMATIC - C2



VEL OCT GATE REPT

Main Display

The display will indicate when a snapshot is active. The [Load] & [Undo] buttons flash to indicate a snapshot is actively saved.

Performing with the sequencers may continue. Edits and adjustments to parameters to add life and energy to live performances, create drops or breakdowns or deviate from the routing pattern arrangement. Restoring the original state is then quick and easy. Sequencer can also be saved in snapshot active, although the current pattern will not be set to that of the snapshot pattern.

Release Snapshot  or  Tap [Load] or tap [Undo] to release the snapshot. The original, pre-edit state of all sequencers is recalled.



Cancel a Snapshot  +  Hold [Shift] and tap [Load] or tap [Undo] to cancel and clear the active snapshot.



 + 

### Arming Mutes in a Snapshot

It is possible to prepare the mute states within an active snapshot prior to releasing. This will allow the continuation of the performance with the original states applied but with the additional benefit of having the individual sequencers or multitrack tracks muted or unmuted on snapshot release.

#### With a snapshot active

Set Mutes / Unmutes  +   Hold [Mute] + double tap Seq [1] - [8] or in a multitrack sequencer, double tap track [Pad] column 1, row 1-8 representing each track.

 +  



On snapshot release the original or edited mute states will be applied. These can then be muted or unmuted in the [Perf], performer page. Multitracks can also be changed in the normal main grid, but the other mode sequencers will need changing in the performer page as the perf and sequencer mode mutes are handled differently.

## 5.9 Other Tools

A few other tools are available in ONE that can be setup and used for more niche applications.

### Monome Grid

OXI ONE can be set to monome view, an 128 grid device. This is configured when powered up so start this process with ONE powered off.

Monome Grid  +  Hold [Shift] + Power on ONE.  
Restart by turning off and on to reset to normal state.

### MIDI Remote Control

Remote control of ONE from an external DAW or MIDI device is possible. Full details can be [found here](#).



# Modes

OXI ONE has eight sequencers, each can be configured with one of nine unique sequencer modes. These modes allow a sequencer function to be chosen to match the project needs. For example, a mono mode sequencer is ideal for simple bass lines or lead melodies. Also useful to control note orientated drum machines. A multi track sequencer offers more flexibility when controlling several related instruments on different channels like complex percussion and automated melodies. Think of the sequencer modes in two categories; constructive sequencers aimed at the building and development of patterns from scratch. These start from a more traditional step by step approach and include Mono, Poly, Chord and Multitrack. These provide the right tools and workflow for defined melodies and beats as well as managing modulation patterns. More organic elements can be added along the journey. The other category of sequencers is the generative models. These use mathematical and logical algorithms to create more free flowing and organic patterns. These include Stochastic and Matriceal which are perfect for exploration and experimentation, but also with the ability to manually edit steps in the process. In addition a set of complimentary tools enable expansion of pattern design and move the topics into advanced sequencing territory. Some tools are integrated to the sequencer mode, for example the chord and poly arpegiators while others like harmonizer may be common to several modes. The tools covered so far are more generic while the ones in this section are more connected to specific sequencers. The tools will be tagged for the specific sequencer in which they serve. Whether creating simple bass lines, intricate melodies or composing drum beats the right tools are in the ONE toolkit.

## 6 Modes

### 6.1 Sequencer Mode Overview

There are none sequencer operating modes. One mode can be set for each sequencer. Choose a mode that will fit the function and style of the project best. Modes can be easily changed for each of the eight sequencers.

Summary of Sequencer Modes		
Mode	Description	Complexity
<b>MO</b> Mono	Monophonic sequencer. Single track with 1 active note per step. Rows are notes within the selected scale and columns are step intervals. Simple and easy to use. Ideal for quickly creating simple melodic lead and bass line patterns. Useful for transpositions and basic performances. A good place to start when learning ONE.	Constructive sequencer, basic
<b>PO</b> Poly	Polyphonic sequencer with flexibility to create more advanced and complex patterns and arpeggios in a single track. Up to 7 active notes can be applied per step. Rows represents notes. Poly is useful for chords and notes with the freedom to experiment. Patterns can be copied from chord to poly mode.	Constructive sequencer, basic
<b>CH</b> Chord	Predefined chords and voicing in a single track. The grid rows represent degree intervals within the selected scale and can be represented piano roll or sequencer style. Columns are step intervals. Chords can have a maximum of 8 notes. Great for creating chord progressions, pads and arpeggiated loops.	Constructive sequencer, intermediate
<b>MT</b> Multitrack	Multitrack mode is a powerful operating environment ideal for up to 8 tracks of monophonic melodic or drum tracks. Think of a drum kit being controlled by one sequencer where each track controls a kick, snare, hat etc and even has a dedicated drum grid view. Multitrack also includes the Euclidean generator per track.	Constructive sequencer, intermediate
<b>SC</b> Stochastic	Rhythmic and melodic pattern generator. The grid in this mode does not serve as a traditional step entry interface but presents a parameter control grid in order to generate patterns. This mode allows linking to chord mode sequencers. Stochastic mode is orientated to probability, randomness and uncertainty and is more about experimentation to search and find musical patterns.	Generative sequencer, advanced
<b>MC</b> Matriceal	Matriceal is build on a matrix of 4 tracks, each with 10 lanes of 16 steps. Notes as well as other parameters can be applied to steps. The core focus of Matriceal is the pattern lane lengths which, when set differently can generate evolving generative patterns, not just for playback and performance of note playback, but also for all of the 10 parameters available per track.	Generative sequencer, advanced
<b>DM</b> Domino	Domino is a trigger layered sequencer with independent, but synchronized, trigger and note layers. The trigger section will drive the transport and step iteration of the note section, creating interesting and unpredictable sequences, especially when adding accumulation, repeats and logic probability.	Constructive sequencer, Advanced
<b>SA</b> Saga	Saga is a duration based step sequencer that operates with individual step lengths called stages. Each stage has its own independent timing and settings which determines the rhythmic nature of the pattern. The overall sequence duration is governed by the sum of the stages.	Constructive sequencer, intermediate
<b>PY</b> MIDI Player	MIDI Player is a sequencer mode that enables the importing and playback of MIDI phrases and patterns. The .MID formatted MIDI files are stored on the SD card and can be loaded to the MIDI Player sequencer for playback.	MIDI File player

## Summary of Sequencer Options

Sequencer tools for each modes									
Functions not listed apply to all									
Tool / function	Mono	Poly	Chord	Multitrack	Stochastic	Matriceal	Domino	Saga	MIDI Player
Tracks	1	1	1	8	1	4	1	1	1
Notes per step	1	7		1	-	1	4	4	-
Mod Lanes	8	8	8	8	8	8	8	8	8
Step Recording	Yes	Yes	Yes	Yes	-	-	-	-	-
Performer	Yes	Yes	Yes	Yes	Yes	Yes	Yes	Yes	Yes
Accumulator	Yes	-	-	-	-	-	Yes	Yes	-
Harmonizer	Yes	Yes/Source	Source Only	Yes	Yes	Yes	Yes	Yes	Yes
Arpeggiator	Keyboard	KB & Grid	KB & Grid	Keyboard	Keyboard	Keyboard	Keyboard	Keyboard	Keyboard
Roller	Yes	Yes	-	Yes	Yes	Yes	Yes	Yes	Yes
Generator	Yes	Yes	Yes	Yes	-	-	-	-	-
Random Generator	Yes	Yes	Yes	Yes	-	-	-	-	-
Drum Pattern Generator	-	-	-	Yes	-	-	-	-	-
Pick & Place	Yes	Yes	Yes	Yes	-	-	-	-	-
User Chords	-	Yes	Yes	-	-	-	-	-	-

## Sequencer Considerations

- Each sequencer has 8 independent modulation lanes. These are decoupled from the main note sequencer for a more polymeric experience. The start and end therefore can be set independently for modulation and note lanes. Check out the modulation section for more information.
- The VEL, GATE and REPEAT global functions can typically be modulated and carry their own modulation lanes in many of the modes, accessed by pressing the knob.
- The primary sequencer pad colors is based on the sequencer setting. The colors used in these examples may therefore differ if the sequencer color or mode is changed.
- Random generation of notes or steps for several sequencers is possible using the randomization tools. These may be applied differently between modes and some parameters are unavailable.

## 6.2 General Sequencer Setup

Each sequencer has a collection of settings specific to the sequencer or track. The available sequencer menu options will depend on the sequencer mode selected. Each sequencer can be configured to operate in one of nine modes. The currently active mode is displayed top left in the sequencer view page. Access to the sequencer settings is performed using [Shift] + Sequencer [1] - [8].

When working with drum and percussion based devices bear in mind that the note alignment between the OXI ONE MkII and the device may need careful consideration. For example, consider how notes are mapped to each drum sound. Avoid note and octave settings or modulation that may give unexpected outcomes.

The generic options are covered here and mode specific elements will be described in the description for the sequencer mode.

### Sequencer Mode Selection



#### Sequencer Settings

Hold [Shift] + tap [1] - [8]. The settings menu will open which consists of multiple pages. Tap [Page] to cycle through the pages or hold [Shift] + tap [1] - [8] again.

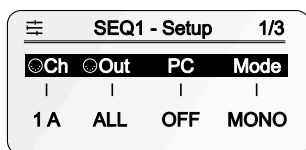

#### Sequencer Mode

In Page 1, turn (Knob 4). Scroll to navigate through the mode options. Press (Knob 4) when highlighting the chosen mode type to confirm assignment to the sequencer.



#### Mode types available:

Mono, Poly, Chord, Multitrack, Stochastic, Matriceal, Domino, Saga and MIDI Player

#### Mono to Poly

A Mono sequencer and its notes can be converted to a Poly sequencer simply by changing the mode of the mono sequencer to poly mode. Notes will be converted using Chromatic mode in the destination poly seq, so the scale may need changing afterwards.

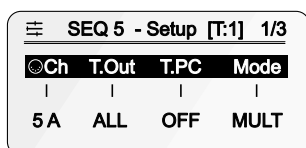
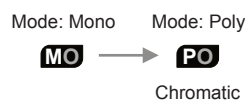

#### Multi Track Mode

For the multi track mode sequencer the individual tracks can be configured. Press a column 1 [Pad] to select a multi mode track. The parameter 'T' represents track, example T.Out.

The sequencer setup options are unique for each sequencer enabling control of its configuration. The settings apply to each sequencer or in the case of a multitrack mode sequencer, apply per track. In the default menus, voice count is directly available in poly mode and track swing is represented for multitrack mode. Use one of the four encoders, (Knob 1) - (Knob 4) to change the settings.

## Sequencer Setup Selection



+



### Sequencer Settings

Hold [Shift] + tap [1] - [8]. The settings menu will open which typically consists of three pages. To cycle through the pages, hold [Shift] + tap [1] - [8] again.



With the sequencer settings page open, tap [1] - [8] to select any sequencer along with its displayed sequencer settings page

Page 1 - Sequencer setup.

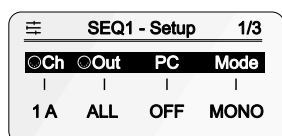

Page 2 - Sequencer setup.

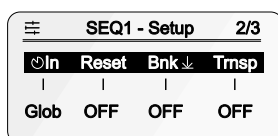

Page 3 - Sequencer setup.

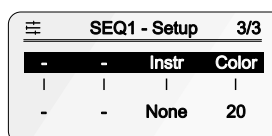

Ch	Out	PC	Mode
Global MIDI channel	MIDI output port	Program change	Sequencer mode
The MIDI channel for the output. Set for the sequencer or each track in multi mode.	The physical port for the MIDI channel output. Select from; ALL, USB, TRS or BLE. Does not affect CV/Gate outputs.	Program change message to send out over the selected MIDI channel. Sent at pattern load or as configured in the arranger.	Sets the mode for the selected sequencer. Mono, poly, chord, multi, stochastic and matriceal options.

Ch, Out & PC can be set per sequencer or per track in multi. Ch per track for matriceal mode

In	Reset	Bank	Trnsp
Punch-in quantization	Reset after # bars	Bank change	Transpose Enable
When stopped, sets countdown for sequencer launch in order to synchronize the sequencers. When playing, triggers the time interval to reset playback.	Resets the sequencer after a defined number of bars in order to re-synchronise all tracks. Options, 1-64 bars.	Sets a bank change CC message to send out on the MIDI channel along with program change message.	Enables MIDI In to be exclusively used for sequencer note transposition i.e. not for arp etc. Relative to root / base for the sequencer or track.

nVoice / T.Swng	Instr	Color
Various options applied per mode. For example, Poly mode: Selects number of voices i.e. notes per step. Multi mode: Swing per track.	Instrument definition	Sequencer color
	Assigns a pre-defined set of mappings for the selected instrument from the definition library. Can be imported or created from the OXI App.	Color scheme selection for the sequencer notes, piano roll, keyboard, patterns, and arranger lanes.

↓ Parameters are changed with the respective knob. Parameters changed but that need to be confirmed to make active will be shown with a \* symbol. To confirm a parameter change and make it active, press the knob after editing.

## 6.3 Mono Sequencer Mode



Mono or monophonic mode is the most basic of the ONE sequencers and is a useful 'go-to' option for getting started and moving quickly. Mono mode has one track and is the ideal mode for performing, transposing melodies and simple lead lines and controlling automation of parameters. The grid columns represent a page of up to 16 steps and the rows represent a piano roll style of musical notes within the current scale. A maximum of 128 steps are available across the 8 pages of the grid. Each step can host one note. Rows can be scrolled up or down to access the notes of each octave available in the range. It is also possible to convert a mono sequencer and its notes to a poly sequencer by simply turning mode from 'Mono' to 'Poly'.

### Viewing & Editing a Mono Sequencer

**Grid View:** Example: Chromatic Scale, Root C2

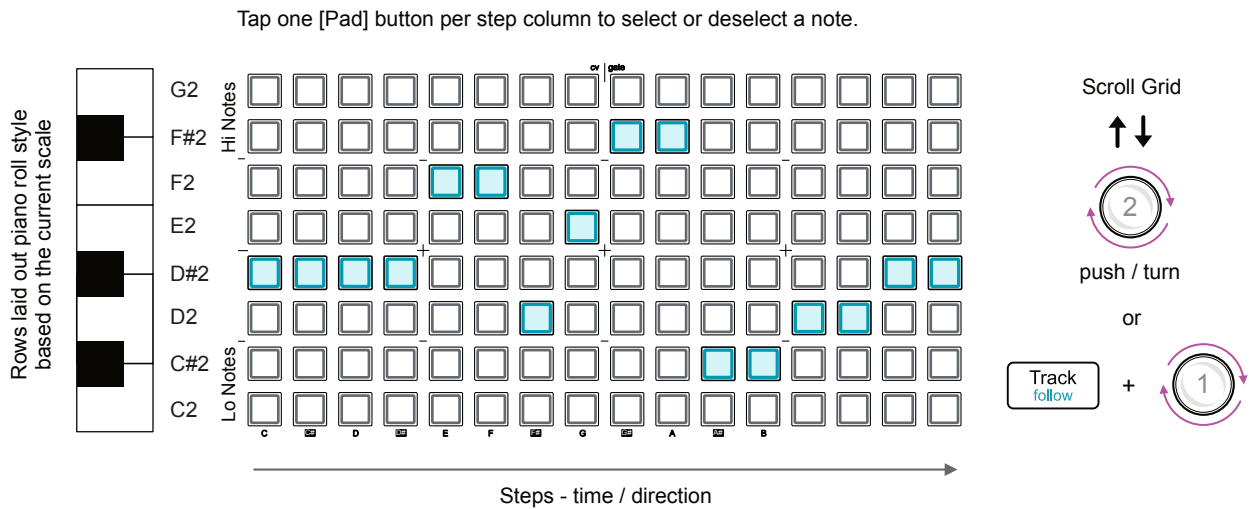

The pattern will be monophonic, with a maximum of one note per step.

**Activate or deactivate a step.**  
Quickly tap [Pad].



Tapping any pad in a column will select it, or deselect if already active. If a step already exists in the column, the new step will replace it.

**Create a tie.**  
Hold 1st [Pad] + tap last [Pad]



Ties all the pads between the two pressed to play as a continuous note. Tap a single pad within the tie sequence to break the tie.

**Inverted tie.**  
Hold last [Pad] + tap 1st [Pad].

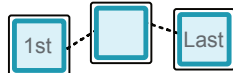

Creates a sequential series of trigger notes between the two pads pressed. This will either be fills, which trigger a sequence of the same note or random note fills. This is set in config > workflow.

**Muting steps.**  
Hold last [Mute] + tap [Pad].



Mute or unmutes an individual step. Muted steps are lit purple.



—Note—

In Mono mode, any existing step notes that are not visible in the current pad range will be indicated by the illumination of the top or bottom row of the grid pads to indicate that notes exist off the grid in the indicated column. Off grid, upper notes are lit white and lower notes are lit red. Scrolling the octave range will bring these notes into view. The octave intervals are also shown when navigating with dimly lit white and red rows.

### Mono Sequencer Parameters

The generic details of the sequencer setup, track and step options have been covered elsewhere in this manual. Here is a refresher of the options for the mono mode sequencer with any further details on mono mode specific parameters detailed additionally. The [Page] button will flash to signify that multiple pages exist. Press [Page] to cycle through the available pages. Hold knob to reset parameter.

### Sequencer Setup Options

 +  The sequencer setup is accessed by holding [Shift] + [1] - [8].

SEQ1 - Setup 1/3			
Ch	Out	PC	Mode
1 A	ALL	OFF	MONO

SEQ1 - Setup 2/3			
In	Reset	Brk	Tmsp
Glob	OFF	OFF	OFF

SEQ1 - Setup 3/3			
-	-	Instr	Color
-	-	None	20

### Track Menu Options.

 Mono mode has a single track so these settings operate globally for this sequencer mode. Press the [Track] button to access. Hold a knob to clear the value.

Track Menu			
↑	Dir	×Div	Div
0	→	OFF	1/16

- Oct.** Navigate grid view, up or down. Knob 1.
- Dir.** Playback direction. Knob 2.
- Div.** Randomisation of time division. Knob 3.
- Div.** Sequencer time division. Knob 4.

### Step Options.

Some step parameters can be edited globally, covering all steps, or can be edited at an individual step level. Multiple steps can also be edited collectively.

 Global - Press [Step]

Step/Accml Global			
Rept	Durat	. . .	
...	...	...	...
Offst	AcmM	-	-
...	Step		

Tap (Knob) for the selected parameter to edit in order to switch between the upper or lower options in a dual parameter row display.  
**AcmM.** Mono mode has a per step or per track accumulator.

 Individual Step\* - Hold step [Pad] +  [Page] to cycle through pages.

\* Multipress is also possible for multiple step edits along with the step range selection method.

Stp 2 J D2 1/3			
Vel	Oct	Gate	Trig
75	+0	50	100%

Stp 2 Submenu 2/3			
Rept	Durat	. . .	
No	x 1	±0%	±0%
Offst	CVGld	J Rng	Rpt%
0%	0%	0st	100%

Stp 2 Accum 3/3			
Amt	Mode	AcmI+	AcmI-
+0st	Wrap	+7st	-0st
Total	Trig	%Mde	Acm%
+0st	All	Iqnor	100%

# 6 Modes

## Transposing Notes in Mono Mode

### Transpose all notes

Hold Seq [1] - [8] + tap [Pad].

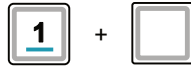

Hold the sequencer button and tap any empty pad higher or lower.

Direction of transposition and interval is determined by the pad pressed.

### Examples

#### Transpose Down

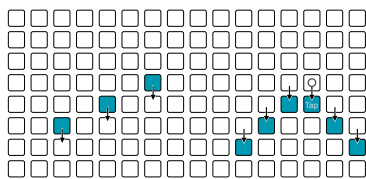

Tapping an empty pad in a column above or below an existing note will transpose all notes relative to the existing column note.

#### Original Notes

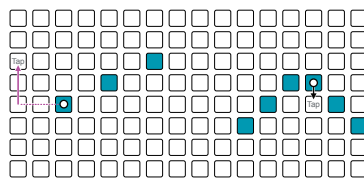

#### Transpose Up

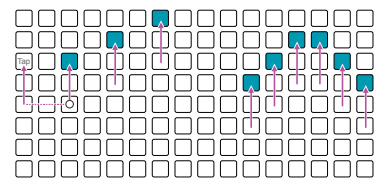

Tapping an empty pad on an empty column will transpose all notes relative to the nearest, right side note.

Tap Pad tapped

↕ Direction transposed

■ Existing notes

○ Reference / original note position

## Copying / Pasting Steps

The copy / paste options in mono mode allow copying of one or a cluster of steps.

Copying the mono mode steps will also copy their parameter settings. Pasting steps will be applied with the parameter settings and change or set notes relative to their original note position.



**Copy one or more steps.** Hold [Copy] + tap one or more [Pad]s to copy. Multiple pads can be selected, with the step selection count displayed. Also tied steps can be copied. The first step selected is the anchor reference.



**Paste steps.** Hold [Paste] + tap [Pad] for the destination step pad to paste into. This pad will be the anchor and the reference for pasting multiple steps simultaneously. Also pastes tied steps.

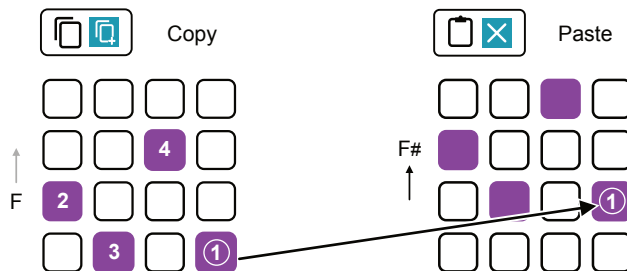

First pad selected in a cluster of notes will act as the anchor and form the reference.

Paste all notes in their relative positions to the first, anchor pad.

## 6.4 Poly Sequencer Mode

PO

Poly or polyphonic mode is similar to mono mode but poly mode can accommodate up to 7 notes per step. Adding an 8<sup>th</sup> note will remove the first note added. Poly mode differs from chord mode in that chord mode uses predefined chord formations and voicing while poly allows free flowing entry of multiple notes per step in any formation. A maximum of 128 steps are available across the 8 pages of the grid. Rows can be scrolled up or down to access the notes of each octave available in the range, especially useful when using multiple notes on a step.

### Viewing & Editing a Poly Sequencer

**Grid View:** Example: Major Scale, Root C2

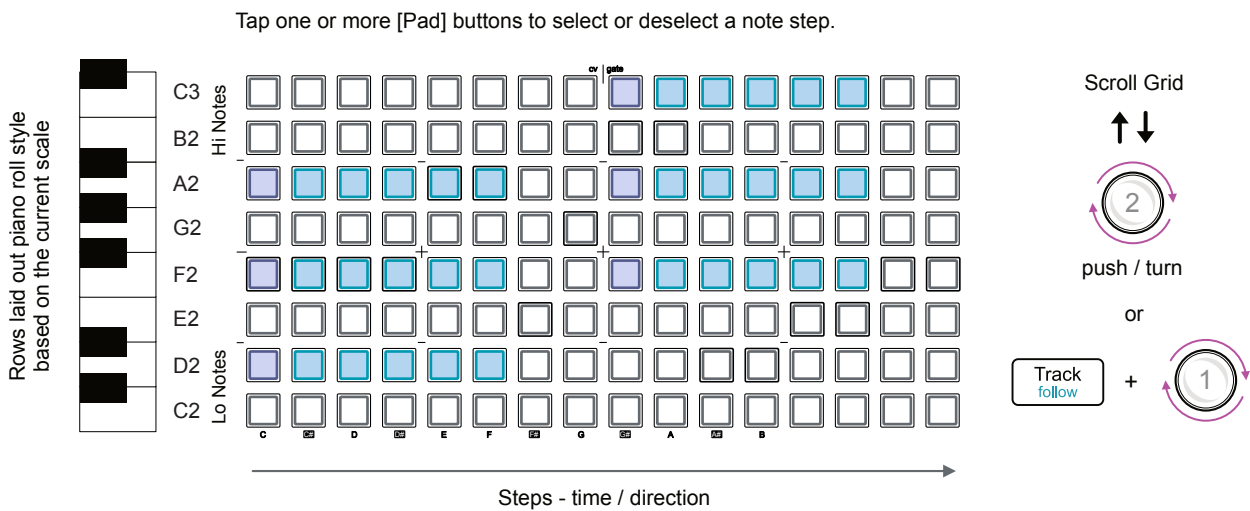

The pattern will be polyphonic, with a maximum of seven notes per step column

**Activate or deactivate step.**  
Quickly tap [Pad].



Tapping any pad in a column will select it, or deselect if already active. Place up to 7 notes per step, the first is replaced if placing an 8<sup>th</sup> note.

**Create tie.**  
Hold 1st [Pad] + tap last [Pad]



Ties all the pads between the two pressed to play as a continuous note. Tap a pad within the tie sequence to break the tie, useful for chords.

**Inverted ties.**  
Hold last [Pad] + tap 1<sup>st</sup> [Pad].

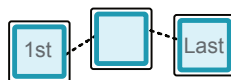

Creates a sequential series of trigger notes between the two pads pressed. This will either be fills, which trigger a sequence of the same note or random note fills. This is set in config > workflow.

**Muting steps.**  
Hold last [Mute] + tap [Pad].



Mute or unmutes an individual step. Muted steps are lit purple.

—Note—

Any existing step notes that are not visible in the current pad range will be indicated in the top or bottom row of the grid to indicate that notes exist off the grid in the indicated column. Scrolling the octave range will bring these notes into view.

## Poly Sequencer Parameters

The generic details of the sequencer setup, track and step options have been covered elsewhere in this manual. Here is a refresher of the options for the poly mode sequencer with any further details on poly mode specific parameters detailed additionally. The [Page] button will flash to signify that multiple pages exist. Press [Page] to cycle through the available pages. Hold a parameter knob to reset.

### Sequencer Setup Options



The sequencer setup is accessed by holding [Shift] + [1] - [8].

SEQ1 - Setup 1/3			
Ch	Out	PC	Mode
1 A	ALL	OFF	POLY

SEQ1 - Setup 2/3			
In	Reset	Bank	Trmsp
Glob	OFF	OFF	OFF

SEQ1 - Setup 3/3			
nVoice	ChMx	Instr	Color
7	Off	None	0

**nVoice.** Number of voices for the poly sequencer. Maximum is 7 is the default. With a setting of 7, a maximum of 7 notes can be added to each step, an nVoice set to 5 allows 5 notes and so forth. Fresh notes are added incrementally, 0 upwards otherwise older notes use the oldest, inactive voice.

**ChMx.** Channel Multiplexing. Hold (ChMx) knob to switch between Lo and Hi options. The ChMx setting will redistribute the active voices, typically created from a chord, to the other incremental MIDI channels, upwards from the base. See Domino sequencer for expanded details.

### Track Menu Options.



Poly mode has a single track so these settings operate globally for this sequencer mode. Press the [Track] button to access.

Track Menu			
↑↓	Dir	×Div	Div
0	→	OFF	1/16

**Oct.** Navigate grid, up or down. Knob 1.

**Dir.** Playback direction. Knob 2.

**Div.** Randomisation of time division. Knob 3.

**Divis.** Sequencer time division. Knob 4.

### Step Options.

Some step parameters can be edited globally, covering all steps, or can be edited at an individual step level. Multiple steps can also be edited collectively. Poly sequencers include an accumulator per step.



Global - Press [Step]

Step/Accml Global			
Rept	Durat	...	+++
...	...	...	...
Offst	AccmM	-	-
...	Step		

Tap (Knob) for the selected parameter to edit to switch between the upper and lower options in a dual parameter row display.

**AccmM.** Poly mode has a per step or per track accumulator.



Individual Step - Hold step [Pad] + [Page expand] [Page] to cycle through pages.

Stp 2 J D2 1/3			
Vel	Oct	Gate	Trig
75	+0	50	100%

Stp 2 Submenu 2/3			
Rept	Durat	...	+++
No	x 1	±0%	±0%
Offst	CVGld	JRng	Rpt%
0%	0%	Ost	100%

Stp 2 Accum 3/3			
Amt	Mode	Accm+	Accm-
+0st	Wrap	+7st	-0st
Total	Trig	%Mde	Accm%
+0st	All	Iqnor	100%

Transposing Poly Notes & Chords

**Transpose all Notes**  
Quickly tap Seq [1] + [Pad].



Hold the sequencer button and tap any other pad higher or lower. Direction of transposition and interval will be determined by the pad pressed.

Examples

Transpose Up

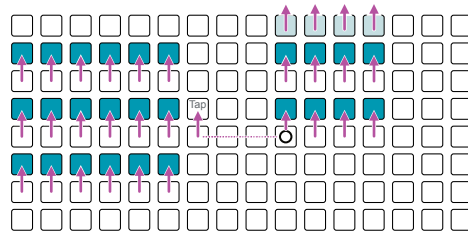

Tapping an empty pad on an empty column will transpose all notes relative to the lowest, right side note. Illustration also shows the notes that are located higher, off the grid.

Original Notes

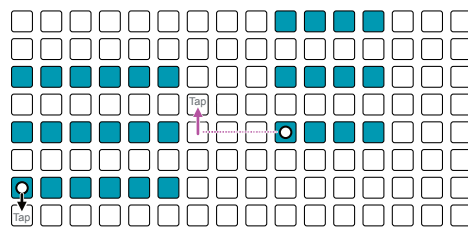

Tapping any of the last three columns on the right will not transpose as there is no reference note to the right.

Transpose Down

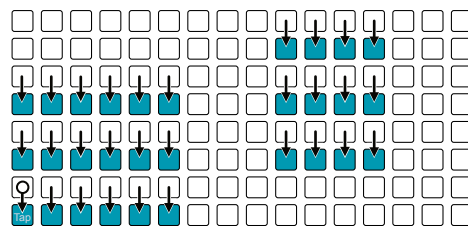

Tapping an empty pad in a column with an existing note above or below will transpose all notes relative to the lowest column note.

Tap Pad tapped    ↓↑ Direction transposed    ■ Existing notes    ○ Reference / original note position

## Copying / Pasting Steps

The copy / paste options in poly mode can be quite powerful and useful. Chord mode sequencers can even be copied and pasted into a poly mode sequencer to expand the options for editing chords and tweaking progressions.

Copying the poly mode steps will also copy their parameter settings. Pasting steps will be applied with the parameter settings and change or set notes relative to their original note position.



**Copy one or more steps.** Hold [Copy] + tap one or more [Pad]s to copy. Multiple pads can be selected, with the step count displayed. Also copies tied steps. The first step selected is the anchor reference.



**Paste steps.** Hold [Paste] + tap [Pad] for the destination step pad to paste into. This pad will be the anchor and the reference for pasting multiple steps simultaneously. Also pastes tied steps.

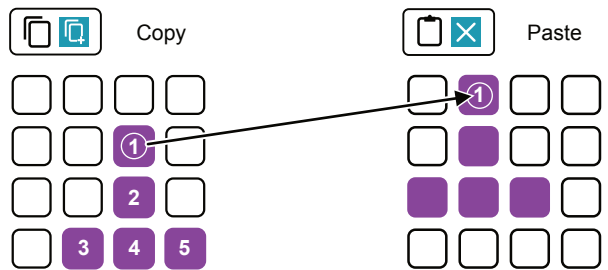

First pad selected in a cluster of notes will act as the anchor and form the reference.

Paste all notes in their relative positions to the first, anchor pad.

The guide given above for copying steps is particularly useful for poly mode sequencers. However the same process can be applied in the mono mode when copying and pasting one or groups of notes. The process of copying and pasting columns detailed below is more useful in poly mode especially when building chord melodies.



**Copy column of steps.** Hold [Copy] + tap an empty [Pad] from the column of notes to copy. Multiple columns with multiple notes can be selected, with the column count displayed. Also copies tied steps. The first step selected is the anchor reference.



**Paste column steps.** Hold [Paste] + tap [Pad] for the destination column to paste into. The copied columns will be pasted. A quick way to paste chord progressions

**Poly Arpeggiator**

**PO**

Poly mode has a dedicated arpeggiator which uses the notes on the poly grid as the source from which to create an arpeggio instead of the keyboard. Access to the poly arp is made using the [Arp] button in a poly sequencer in sequencer grid view. The poly arp is integral to the poly mode engine but still follows the general principles and functionality as the keyboard arpeggiator.

Ensure a multiple set of notes are programmed into steps on the grid, typically set to longer notes, or tied notes in a chord. The sequencer must be playing. The arpeggiator will operate at the defined time division for the duration of the sequenced notes. Individual short notes may not sustain the arpeggiator pattern generation for long enough so ensure the source notes allow the arpeggio to be generated over the appropriate time period.

**Accessing the Poly Arp**

**Select the Poly Arp Options.**  
Tap [Arp].



Tap [Arp] to select. Hold to temporary view arp options. Grid must be in poly mode and sequencer view. If in keyboard view, only the generic keyboard arp is selected.

S.Arp OFF				1/2
Type	OctV	Accnt	Div	
ON	0	+0%	1/16	
Rot	Len	Puls	Rept	
+0	1	1	0	

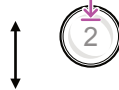

Tap (Knob) of the respective parameter to toggle between the upper or lower option for editing.  
*Corner tagged parameters can be modulated.*

SEQ Arp				2/2
GTim	Grov	Reset	-	
0%	Grv 1	ON	-	



Tap [Page] button to cycle through the arp pages. Page button flashes when pages are available.

Poly Arp Parameters				Page 1/2
<b>Type</b>	<b>OctV</b>	<b>Accnt</b>	<b>Div</b>	
Off / On - Arp algorithm	Octave voicing range	Velocity accent	Time division	
Sets the arp on/off. On sets the direction and style (displayed in the header) for the musical phrase.	Introduces a number of octave higher or lower notes into the arpeggio.	Varies the note velocity based on the 'Groov' groove template.	Sets the arp specific time intervals. This can be different to the main sequencer.	
<b>Rotate</b>	<b>Len</b>	<b>Puls</b>	<b>Rept</b>	
Euclidean rotation	Euclidean phrase length	Euclidean pulses	Euclidean pulse repeats	
Rotates the Euclidean pulses + right or - left.	Sets the total length of the Euclidean phrase.	Number of pulses in the Euclidean generator.	Generates repeats for pulses in the Euclidean generator.	

Poly Arp Additional Parameters			Page 2/2
<b>Gtime</b>	<b>Grov</b>	<b>Reset</b>	
Timing of the groove	Groove Templates	Reset	
Adjusts the velocity timing of the arp notes within the selected groove.	Selects a groove template. These are applied to the velocity profile of the arpeggio.	Option to reset the arp pattern to start at the beginning when new arp notes are applied.	

# 6 Modes



## Keyboard View





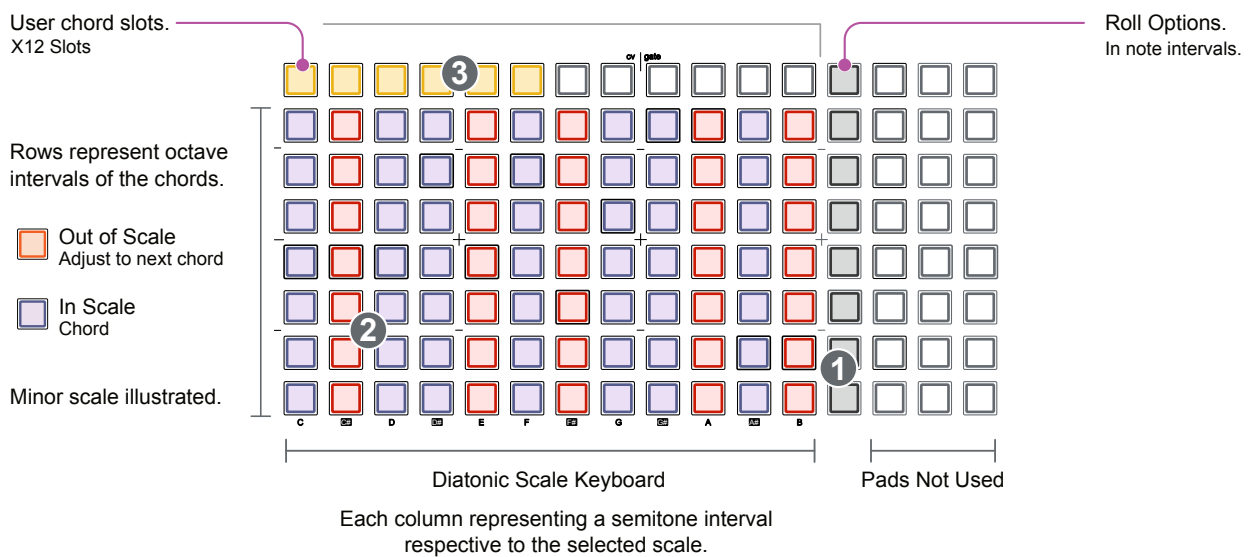

The keyboard view in a poly sequencer offers some unique features for working with chords. The keyboard itself pretty much operates with a 'lite' version of the chord keyboard and also has the ability to play and capture up to 12 chords to a user slot library. These chords can then be used to 'pick and place' into the sequencer pattern or can be played in performance mode for the Poly sequencers.



Press [Keyboard] button to select or deselect keyboard view in a Poly sequencer.



### While Playing the pattern [Play].

- 1 Set Roll Interval.**  
 Select keyboard [Pad].  Tapping any pad in a column will choose a note interval for playing the note or chord roll.
- 2 Play chord.**  
 Select keyboard [Pad].    Hold the pads in the columns will trigger the chord. Chord layout is based on the current scale and root.
- 3 Store the Chord.**  
 While holding a Chord.   While holding the chord or note, hold a user chord slot in which to store the chord for > 2secs . These are unlit on the upper row and lit orange when a chord is stored..  
 C Maj

### Pick & Place Chords

To sequence chords from the stored slots, firstly tap one of the stored, upper row pads to choose the chord. Switch to the sequencer mode and tap any pad to place the chord in the sequencer grid. Repeat the process to place more of the same chord or switch back to the keyboard mode and pick another chord to place.

Stored chord are also accessible from the Performance mode page and can be played from the Perf Grid.

## 6.5 Multitrack Sequencer Mode

So far we have seen mono and poly modes operate one track over a piano roll style grid. Multitrack is different in that it controls 8 independent, monophonic tracks. The default working view presents each grid row as a representation of each of the tracks, numbered bottom to top 1-8. Each track can have its own individual start and end, length and time division. If desired, a groove template can be applied to each individual track. Multitrack is a versatile and flexible mode, ideal for creating drum kits or developing multi-instrument melodic sequences.

Each track lane is independent and can be set with its own start / end range as can the 8 modulation lanes and the primary parameters, velocity, gate and repeat modulation lanes.

### Viewing the Multi Sequencer

**Grid View:** Tracks structured 1-8, bottom to top.

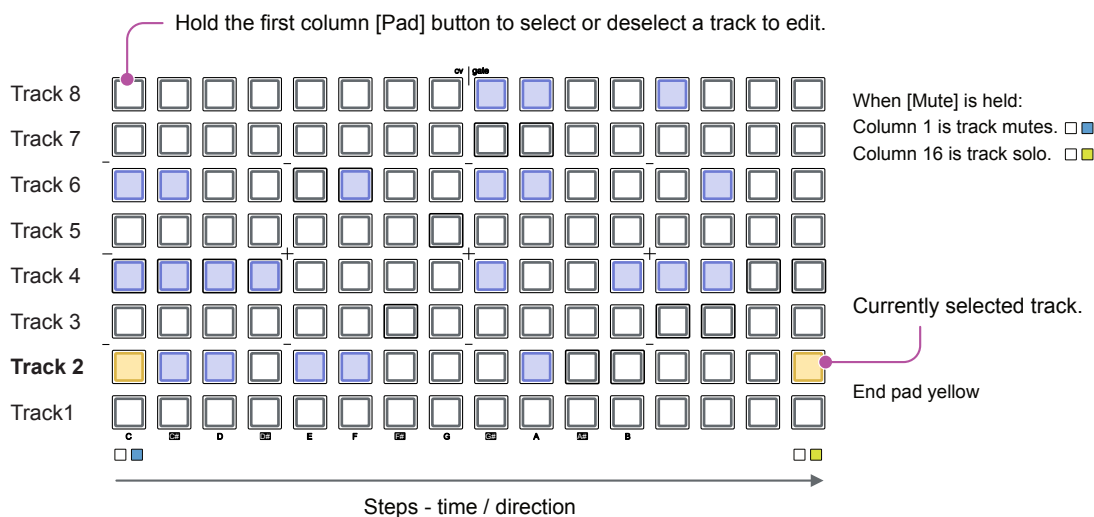

Each track will be monophonic, with a maximum of one note per step. Sequencer requires 8 voices.

### Selecting a Track

**Select the Sequencer.**  
Quickly tap [Pad].



Before selecting any tracks, select a multitrack mode sequencer. Tap sequencer pad [1] - [8]. The first column in the 16 x 8 pad grid serves as track selection as well as a note step in a pattern.

**Select a Track.**  
Tap [Pad] - 1<sup>st</sup> Column.



Tap column 1 [Pad] to select the track. Pad will be lit yellow when no trigger is present. First tap of a new row will always select the track first not the note. Tap the pad again to place a note trigger on the step.

**Select a Track.**  
Hold [Seq] + [Pad] - 1<sup>st</sup> Column.



An alternate method for track selection is with the sequencer button. Hold the multi sequencer [1] - [8] + tap first column [Pad] to select the track. Pad will be lit yellow unless a note exists.

—Note—

The 'track select priority in multitrack' option found in the config > workflow settings will enable that tapping any pad will automatically select the track for the pad row chosen. Default is on.

## 6 Modes

Editing a multitrack sequencer is typically performed on a track by track basis. Using the functions as normal will affect the selected track only. Some functions can however be edited for all tracks simultaneously. When changing an applicable setting for all tracks, hold the sequencer button then apply the command for the function.

### Editing Functions for All Tracks

**Change a parameter.**  
Hold [Seq] + [Function]

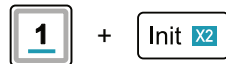

To edit a function for all tracks, hold seq [1] - [8] for the multitrack seq while also holding the selected function button, e.g. Init.

Example 1.  
Hold [1] + [End] + [Pad]

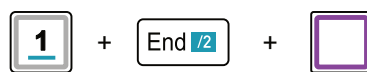

Change end position for all tracks in the multi sequencer 1.

Example 2.  
Hold [1] + [Shift] + Tap [Paste]



Clear all track steps.

**Reset all Tracks.**  
Hold [Shift] + Hold [Paste]



To clear all tracks notes, time division, length, offsets etc, hold [Shift] + Hold [Paste] > 2 seconds for its secondary, clear function. MIDI Channel remains intact.

### Editing Functions for Each Track

**Track parameters.** Many settings can be configured on a per track basis, for example the start and end can be adjusted for each track independently. The default mode is to edit the selected track when using the functions. Other track orientated parameters include MIDI channel and output port, note offset, time division, playback direction can be set per track in the [Track] menu.

Track 3: MIDI 3A	E2		E2		C2						D3			D3			1/32
Track 2: MIDI 1A	F2									C2					E2		1/16
Track 1: MIDI 1A		G3		E2		G3		G3				G3	E2				1/8

**Step parameters.** Primary parameters like notes, velocity, gate and trig probability can be set to a value for each step. Edit steps by holding [Pad] + turn (Knob) for the parameter to adjusting for the step.

**Global Parameters.** Adjusting the parameter directly, i.e. turn (Vel) knob 1 will change the all of the parameter values for the selected track only. To change these for all tracks, hold sequencer button [1] - [8] + turn (Knob) for the primary parameter to edit.

—Note—

Steps can be copied following the normal convention of [Copy] + [Pad]. Steps can also be copied and pasted across tracks. Also an individual track can be cleared of all steps. With the track selected, hold [Shift] + tap [Paste].

**Muting & Soloing Multitracks**

The entire sequencer can be muted using [Mute] + sequencer [1] - [8]. Also each of the 8 tracks can also be muted individually or can be soloed. The option to keep mutes in multi mode when loading patterns can also be set in the config > performance menu.

**Mute a track.**

Hold [Mute] + [Pad] Column 1

Hold [Mute] + Column 1 [Pad] of a multi track sequencer will act as the mute command for each track. Tracks are numbered 1-8 bottom to top. While holding mute, unmuted tracks are lit blue, muted tracks unlit.

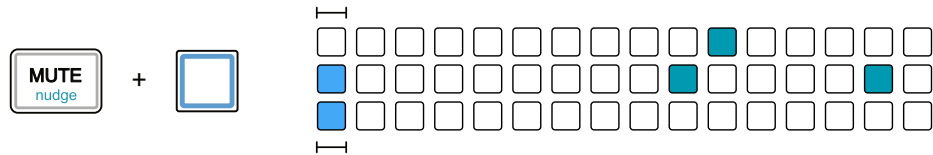

**Soloing tracks.**

Hold [Mute] + [Pad] Column 16

Hold [Mute] + Column 16 [Pad] of a multi track sequencer will act as the solo command for one or more tracks. Tracks are numbered 1-8 bottom to top. While holding mute, soloed tracks are lit yellow.

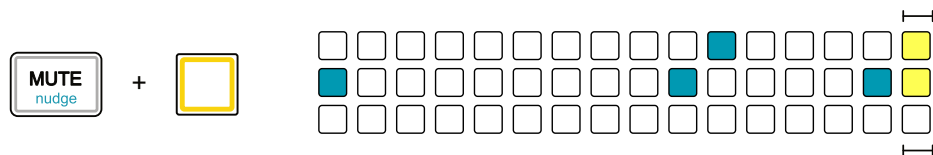

Hold [Mute] + [Pad] on any other column will also be used to mute an individual step notes or notes.

Muting and soloing the multi-tracks is also possible in performance mode using the first 8 pad columns of the multi-track. Hold [Shift] in performance mode to switch between mute or solo controls.

**Activating Multitracks for Randomization and LFO Modulation**

Randomization and the LFO can be applied to each individual track in a multi track sequencer. Each track can be activated or deactivated to allow these functions to affect the tracks.

**LFO Track Control.**

Hold [LFO] + [Pad] Column 1

Hold [LFO] + Column 1 [Pad] of a multi track sequencer to activate or deactivate access to the track by the LFO function. Tracks lit orange are affected by the LFO, green lit tracks are not.

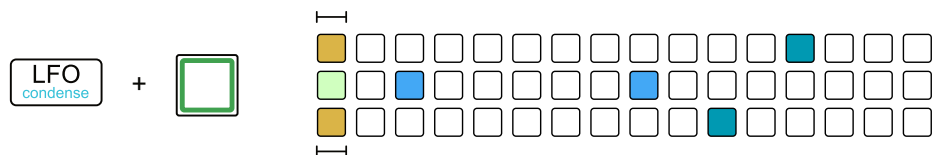

**Randomize Track Control.**

Hold [Randomizer] + [Pad] Column 1

Hold [Randomize] + Column 1 [Pad] of a multi track sequencer to activate or deactivate access to the track by the randomization function. Tracks lit yellow are affected by the randomizer, green lit tracks are not.

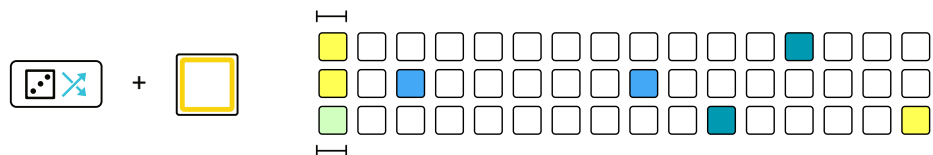

## 6 Modes

### Multi Sequencer Parameters

Multi follows the same principles for the sequencer setup, track and step options which have been covered elsewhere in this manual. However many of the multi mode options apply to each of the eight tracks rather than just an overall single sequencer. The [Page] button will flash to signify that multiple pages exist. Press [Page] to to cycle through the available pages.

### Sequencer Setup Options

The sequencer setup is accessed by holding [Shift] + [1] - [8]. The header in each page displays the selected sequencer 1-8 and also the selected track T1 - T8. Tap [Pad] in column 1 to select a track.

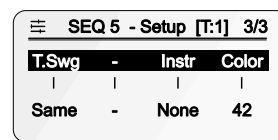
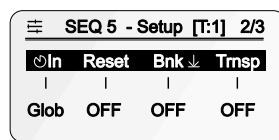
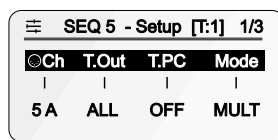

The sequencer setup 'T' parameters, i.e. T.Out, T.PC, and T.Swg plus Bank refer to a track specific setting. These can be set for each individual track. Other parameters are global and any changes in these pages will affect all tracks in the sequencer. Some parameter edits need confirming by pressing the knob.

**T.Swg.** Sets the swing value per track. This can be set between 10-90% or to the 'Same' option which will match the global swing value set with [Shift] + (Swng) Knob 2 in the main sequencer view.

### Track Menu Options.

Multi mode has a 8 tracks where specific settings can be configured for each by using the track menu options. Each collection of parameter settings in these pages is relevant only for the selected track.

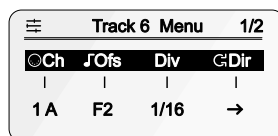

- Ch.** MIDI Channel out. Track specific. Knob 1.
- Ofs.** Base note offset for all notes in the track. Knob 2.
- Div.** Randomisation of time division. Knob 3.
- Dir.** Playback direction for the selected track. Knob 4.

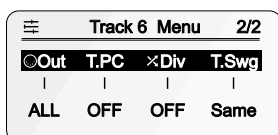

- Out.** MIDI output port for the track, USB, TRS, BLE, ALL.
  - T.PC.** MIDI Program Change output.
  - Div.** Randomisation of time division.
  - T.Swg.** Track swing amount or 'Same' to match global setting.
- T.Swg also appears on the sequencer settings page 3.

To reset a parameter back to its default setting, press and hold the respective knob for >2 seconds.

**Step Options.**

Some step parameters can be edited per track, covering all steps for the selected track, or can be edited at an individual step level. Multiple steps can also be edited collectively.

 Track Specific - Press [Step]

Step Track 5			
Rept	Durat	. . .	+
...	...	...	...
Offst	CVGld	-	-
...	...		

Tap (Knob) for the selected parameter to edit by switching between the upper and lower options in a dual row display.

**CVGld.** Global pitch change time between consecutive notes. Range 0-100%. Applies to CV only as MIDI doesn't support glide.

 Individual Step - Hold step [Pad]

T5-2		JD2		1/2	
Vel	Note	Gate	Trig		
75	D2	50	100%		

T5-2		Submenu		2/2	
Rept	Durat	. . .	+		
No	x 1	±0%	±0%		
Offst	CVGld	JRng	Rpt%		
0%	0%	0st	100%		

Header shows the track number and the step plus the note on page 1.

**Note.** Edit notes of one or more steps while the [Pad] is held and by turning (Note) knob 2. The available note options will depend on the current scale. Press knob to reset the note value to the base note of the selected track.

# 6 Modes

## Alternate Multitrack views

As well as the 8 track lane view the option to switch the pad grid to an alternate view is possible. This includes a drum pad style layout, more suitable for working with drum and percussion instruments as well as a keyboard style. The parameter column view editor can also be accessed when tapping the parameter knob in sequencer view.

## Drum View

When all tracks are unarmed the drum view is the default option when selecting the keyboard. If a track is armed the view changes to regular keyboard view. This view is ideal when working with percussive and drum style instruments, although it is also possible to use with any instrument.

Drum View - All Tracks / Unarmed

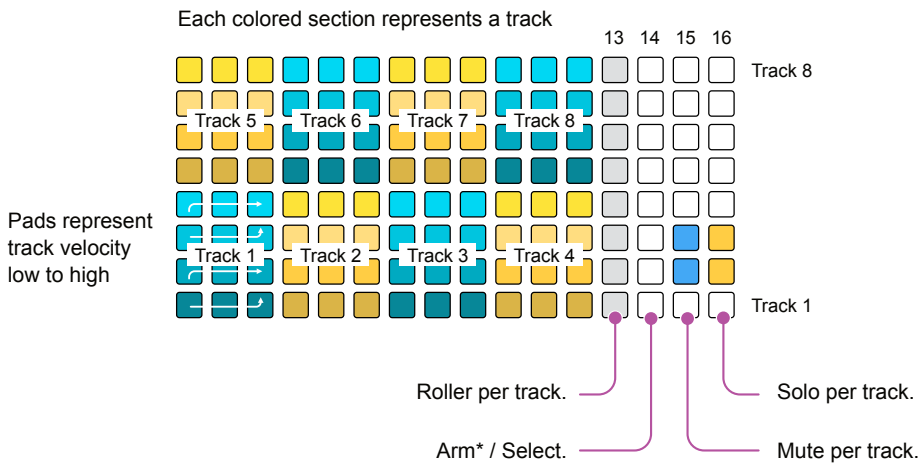

\* Track arming not only selects the keyboard view but also affects the MIDI input filtering behavior when set to off in the configuration.



Regular Keyboard - Single Track / Armed

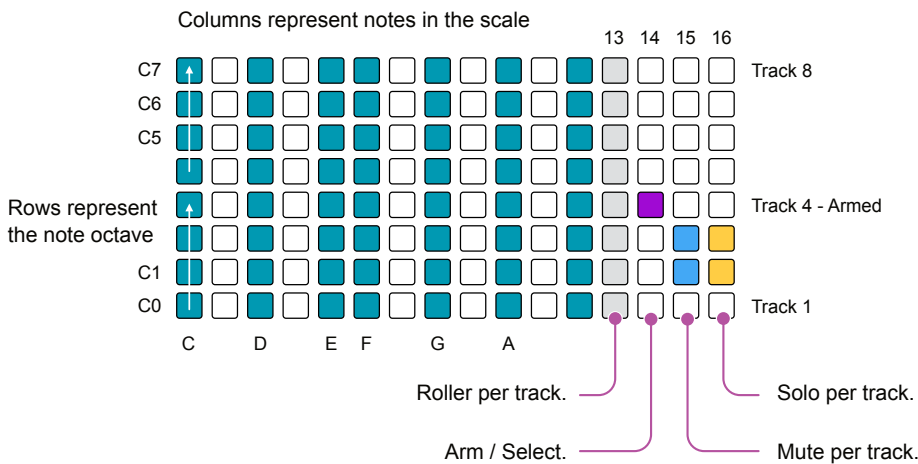

## Regular Keyboard

When a track is armed the grid switches from the default drum view to the regular keyboard representing only the one armed track. Playing or recording with the keyboard will only affect the armed track. Notes are laid out based on the current scale and root. Illustration shows a chromatic scale with root c.

**Piano Roll View**

It is possible to also view one track in the classic ONE piano roll view where each row represents a note in the scale and columns represent steps. Access to the piano roll view is made by tapping or holding knob 2 (Oct) in a multitrack mode sequencer view. The currently selected track will be displayed.

**Grid View: Example: Chromatic Scale, Root C2**

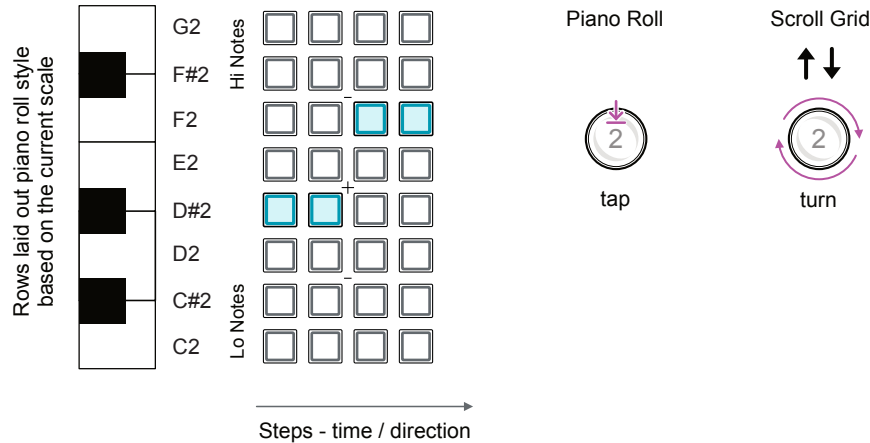

The pattern will be monophonic, with a maximum of one note per step.

**Column Editor View**

The column editor is also an alternative to using the knobs for the velocity, gate and repeat parameter changes when in the sequencer main view. This lays out the pad grid in columns representing the parameter value for each step for the selected parameter and for the selected track. For example, to adjust a velocity profile for track 1.

These parameter modulation lanes for velocity, gate and repeats are also independent with their own start and end but they do follow the note tracks 'Dir' direction control.

**Column View per Track: Example: Velocity profile**

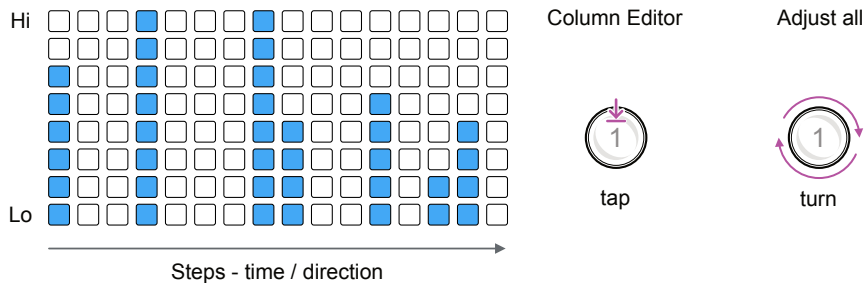

Tap the parameter knob to switch to column editor view. The columns can be edited representing the velocity, gate and repeat parameter value e.g. 0-127, 0-100% etc across the pattern range.

—Note

The preview option is useful to audition any sounds played / assigned into the grid in these views. Hold [Shift] + Tap [Keyboard] to select preview mode. Keyboard button is lit blue in keyboard mode.

## MIDI Input Note Filtering

MIDI filtering setting defines how the incoming MIDI messages are routed to the specific sequencers or in the case of a multitrack, specific tracks. Note filtering allows control of the incoming MIDI message routing and is a setting found in the config > MIDI settings. MIDI filtering is covered in detail later.

While this is a generic option, but it does need specific consideration when used with a multitrack sequencer where the 8 tracks have to be managed. Multitrack arm status also affects the filtering behavior and the filter pays particular attention to root / base notes.

MIDI in Channel filtering	No armed tracks <input checked="" type="checkbox"/>	One armed track <input type="checkbox"/>
Config > MIDI Option	Select in drum or keyboard view	Select in drum or keyboard view
Off	Generally the selected sequencer will listen to any MIDI notes from any MIDI channel. The filter will <u>only check notes, any MIDI channel</u> . Incoming notes will be compared to all track's base/root notes and sent to a matching track. If there are multiple matches, it will send the note to the first track.	The selected sequencer will listen to any MIDI note from any MIDI channel. All incoming MIDI events, any channel, are routed to only this armed track.
MIDI Channel	Generally, each sequencer will only listen to notes from the defined MIDI channel for the sequencer. Multitrack filters notes by the <u>track defined MIDI channel</u> . If tracks have the same channel assigned, notes are routed only to track 1 or the first matching track.	Events are routed to the armed track only from the incoming MIDI channel that matches the track defined MIDI channel. The base/root note for the track is irrelevant.
Ch & Note <i>Multimode specific</i>	Multitrack will filter based on the <u>track defined channel and the base/root note</u> . Routes the incoming note to the tracks matching the base/root for the matching track channels.	Same as above. Events are routed to the armed track only from the incoming MIDI channel that matches the track defined MIDI channel. The base/root note for the track is irrelevant.

## 6.6 Multitrack Generators

MT

Multitrack mode has several integrated generators including the Euclidean style generator, drum pattern generator and random generator. These are very useful and creative tools to help build patterns, experiment and explore musical avenues. The interest expands even further when adding randomization.

### Euclidean Style Generator

The core concept of a Euclidean generator is to take several parameters and apply a mathematical model to generate a pattern. The two main parameters are the length and the pulses. The Euclidean engine then distributes pulses as evenly as possible across the defined length. Other parameters, for example rotation, can also be applied to enhance the function further. The multitrack Euclidean generator is a destructive process, meaning that the pattern generated overwrites all prior steps unless they are locked or fixed in which case they are retained.

**Select Track.**  
Tap [Pad] - Column 1



The generator is applied to the selected multitrack, track. Select track before applying.

**Generator Menu.**  
Tap [Gen]



Opens the Euclidean generator parameter options for the specifically selected track.

To change a Euclidean parameter without applying it to the track, hold [Shift] + turn knob for the respective parameter.



GEN T:3 1/2			
eLen	ePuls	eRot	Dens
16	7	0	+0%
NteR	Nte%	OctR	eInv
0st	30%	0oct	No

GEN T:3 2/2			
Tie%	eLen2	eRot2	NtOrd
OFF	OFF	0	Lin
Lock	ePul2	Logic	Vel%
OFF	OFF	OR	OFF

Example. Euclidean Generation

Length: 16, Pulse: 7



The 7 pulses are distributed as evenly as possible over the 16 step range.

Rotate: +2 → →



Pulses can be rotated left/forwards and right/backwards, wrapping at the length start/end.

Invert: Yes



Pulses can be inverted. When Inv is 'yes' the inactive pulses become active and vice versa.

Density: +15%



Density can add pulses or remove pulses.

# 6 Modes

## Drum Pattern Generator

The drum pattern generator is an exclusive, non-destructive function in multitrack mode that supports the focus on drum and percussion generative sequencing. The drum pattern generator has 3 engines, each found on tracks 1, 2 and 3 and especially aimed at kick, snare and hi hat rhythms.

Drum Generator Architecture

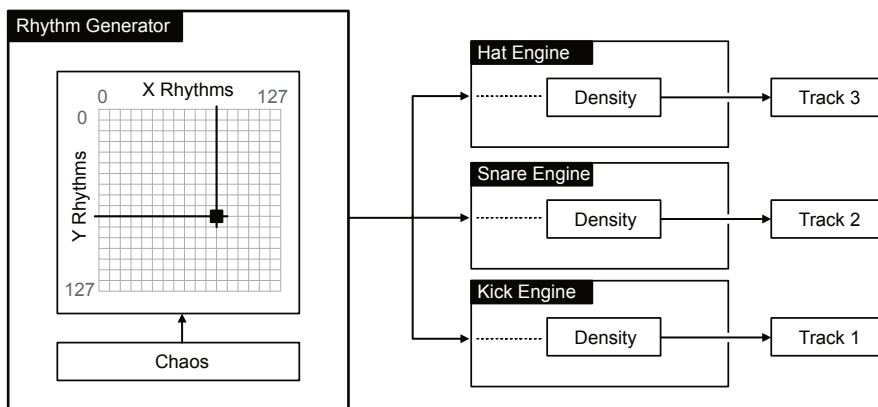

The X & Y parameters define the source model for generating rhythmic patterns. In addition, the option to add some randomization is possible using the chaos parameter. These 3 parameters are common to all engines and therefore apply to all tracks. Density sets the change of triggers being generated. Density is set exclusively for each track to apply triggers and add variation. The pattern is generated on each cycle of the playing pattern. Existing active steps are retained when using the drum generator.

Track 1

Patterns				
Dens	X	Y	Chaos	
30%	0	64	5	

Track 2

Patterns				
Dens	X	Y	Chaos	
OFF	0	64	5	

Track 3

Patterns				
Dens	X	Y	Chaos	
64%	0	64	5	

Generator Parameters			
Dens	X	Y	Chaos
Trigger step density	Rhythm source X	Rhythm source Y	Randomization
Chance of trigger step generation - defined amount. <u>Set per track.</u>	Navigates the 'X' table of patterns to contribute to the rhythm engine. Set for all tracks.	Navigates the 'Y' table of patterns to contribute to the rhythm engine. Set for all tracks.	Applies randomization to the generated X-Y pattern. Set for all tracks.

The pattern must be playing for the drum pattern generator to operate. It is also recommended that to get the full benefit, set the length to 32 steps. Other lengths are possible but the rhythm generators are optimised to work over a 32 step range.

**Playing Drum Tracks.**  
Press [Play]



The tracks must be playing in order to continuously generate the track drum patterns.



# 6 Modes

## 6.7 Chord Sequencer Mode

Chord mode enables chords consisting of up to 8 notes to be played and sequenced by each pad. This offers a fast way to build progressions while at the same time learning about chord theory in practice.

**Chord inversions and voicing.** Voicing is the term used when referring to inversions. Typically the root note of a chord is the lowest bass note. A chord inversion is the adjustment of chord notes in order to place another note in the lowest bass position of the chord instead of the root note. Iterative inversions can be applied. This is also called voicing, the term used often in ONE, and can help make smoother and more musical chord transitions. ONE manages voicing through its parameter application and auto voicing feature in chord mode for the best musical effect coupled with a simple workflow.

The grid can be presented in two main views. Sequencer view represents chords on each row based on the selected scale and by degrees between the grid rows. Also keyboard view gives access to a multi functional grid with a piano roll style chord layout and direct mode control using pads plus the more expanded chord palette.

### Sequencer View: Example: Major Scale, Root C2

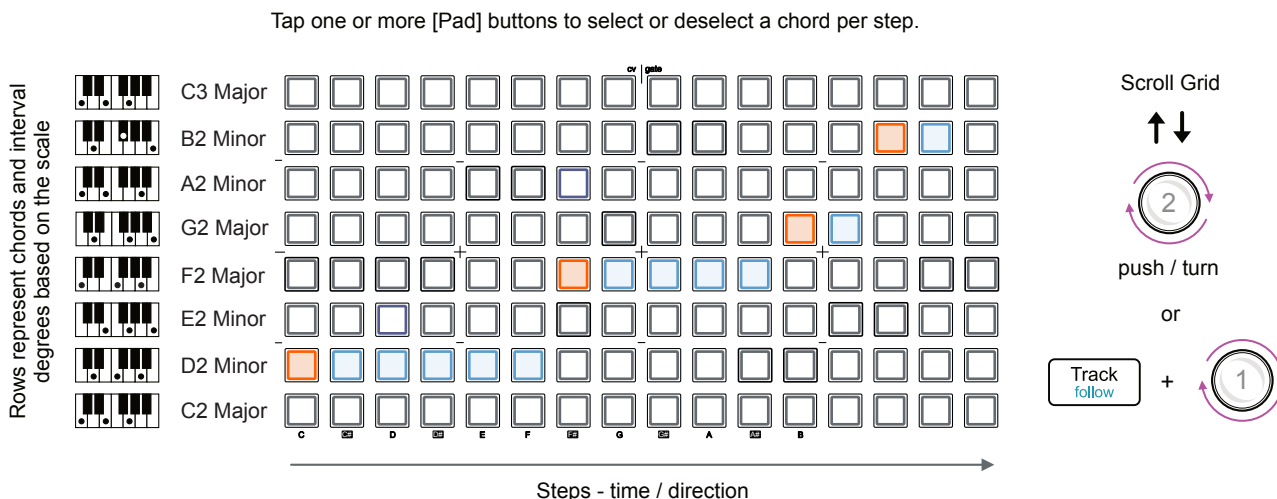

**Activate or deactivate step.**  
Quickly tap [Pad].



Tapping any pad in a column will select it, or deselect if already active. Each pad row represents a chord in the selected scale.

**Create tie.**  
Hold 1st [Pad] + tap last [Pad]



Ties all the pads between the two pressed pads to play as a continuous chord. Tap a pad within the tie sequence to break the tie.

**Inverted ties.**  
Hold last [Pad] + tap 1st [Pad].

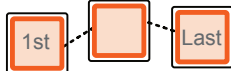

Creates a sequential series of trigger notes between the two pads pressed. This will either be fills, which trigger a sequence of the same chords or random fills. This is set in config > workflow.

**Muting steps.**  
Hold last [Mute] + tap [Pad].



Mute or unmutes an individual step. Muted steps are lit purple. Note that holding [Mute] + Column 1, mutes the entire sequencer.

—Note—

In Chord mode, any existing step notes that are not visible in the current pad range will be indicated by the illumination of the top or bottom row of the grid pads to indicate that notes exist off the grid in the indicated column. Off grid, upper notes are lit white and lower notes are lit red. Scrolling the octave range will bring these notes into view. The octave intervals are also shown when navigating with dimly lit white and red rows.

### Chord Sequencer Parameters

The generic details of the sequencer setup and track and step options have already been covered, so here is a refresher on the general options. Any unique chord mode parameters are described here. The [Page] button will flash to signal if multiple pages exist. Press [Page] to cycle through the available pages.



Page button flashes to signify that multiple pages exist. Tap [Page] to cycle through available pages.

### Sequencer Setup Options



The sequencer setup is accessed by holding [Shift] + [1] - [8].

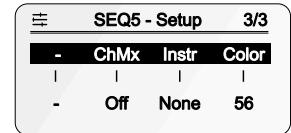
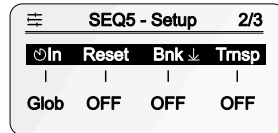
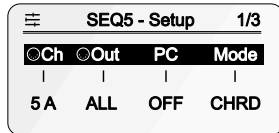

**ChMx.** Channel Multiplexing. Hold (ChMx) knob to switch between Lo and Hi options. The ChMx setting will redistribute the active voices, typically created from a chord, to the other incremental MIDI channels, upwards from the base. See Domino sequencer for expanded details.

### Track Menu Options.



Chord mode has a single track so these settings operate globally for this sequencer mode. Press the [Track] button to access.

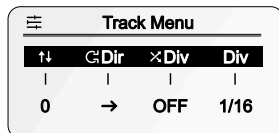

**Oct.** Navigate grid, up or down. Knob 1.

**Dir.** Playback direction. Knob 2.

**Div.** Randomisation of time division. Knob 3.

**Div.** Sequencer time division. Knob 4.

To reset a parameter back to its default setting, press and hold the respective knob for >2 seconds.

## Step Options.

Some step parameters can be edited globally, covering all chord steps, or can be edited at an individual step level. Multiple steps can also be edited collectively while the pads are held. The voicing is also accessible at an individual step or global level. Press [Page] to cycle through multiple page options.



Global - Press [Step]

Step Global			
Rept	Durat	. .	
...	...	...	...
Offst	Strm	-	-
...	...	-	-

Tap (Knob) for the selected parameter to edit, switching between the upper and lower options in a dual parameter row display.

**Strm.** Sets a slight timing offset on each note to play back in order rather than together. This applies a strum style effect. Positive values affect time separation lower to upper notes and negative values affect upper to lower. Range is -100% to 100%.

Chord Global			
Sprd	Type	Voic	Bass
↑↓	↑↓	↑↓	OFF

Quick, direct access, hold [Shift] + [Chord] or use [Page] from within the step menu.

Affects the chords in the sequence globally. See table below for parameter details. Bass affects sequencer and keyboard view.



Individual Step - Hold step [Pad]

Stp 1	G2 minor	1/3	
Vel	Oct	Gate	Trig
75	+0	50	100%

Global control of these parameters is found in the main sequencer 'home' view.

Stp 1	Submenu		2/3
Rept	Durat	. .	
No	x 1	±0%	±0%
Offst	Strm	≡Rng	Rpt%
0%	0%	0st	100%

S:0	Type	Voicing
G root		Open
G minor		No Inver
G min6		Open Voic

See table below for the voicing details. Chords are ordered by complexity top to bottom.

Sprd / S	Type / Type	Voic / Voicing	Bass (Global only)
Spread voicing per step	Type of chord	Voicing or Inversion	Base note
Expands voices of all chords to include a higher octave note of each grade, starting from the lowest note.	Sets the triad chord of the corresponding degree as the base. Voicing inversions can be added as variations.	Selects the inversion for the chord. Open, Open 1 <sup>st</sup> & 2 <sup>nd</sup> and Inversion 1 <sup>st</sup> & 2 <sup>nd</sup> are available options.	Off or when On, sets a lower octave note based on the root of each chord. Option for setting an independent note on its own MIDI Channel.

Parameters titles in this table refer to both the global and individual step page option labels. For example Voic/Voicing is titled 'Voic' in global menu and the same parameter is titled 'Voicing' in the step submenu. These affect the same parameter but for all or individual steps depending on the process. Bass note has priority over voicing spread limit.

Columns 13 & 14, voicing, column 15, spread, and column 16 in keyboard view also give access to editing of these parameters.

To reset a parameter back to its default setting, press and hold the respective knob for >2 seconds.

### Transposing Chords

**Transpose all chords**  
Hold Seq [1] + Tap [Pad].



Hold the sequencer button and tap any other empty pad higher or lower. Direction of transposition and interval will be determined by the pad pressed.

#### Examples

##### Transpose Up

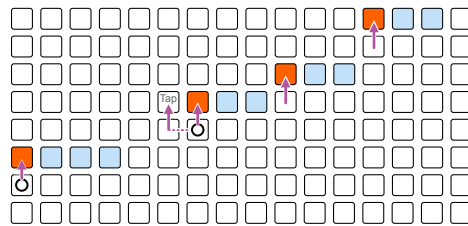

Tapping an empty pad on an empty column will transpose all chords up based on the nearest right side chord as the reference.

##### Original Notes

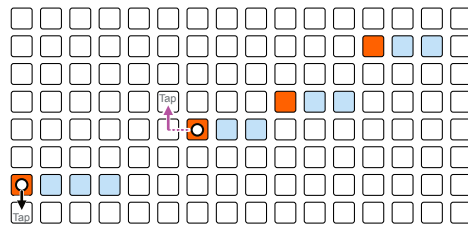

##### Transpose Down

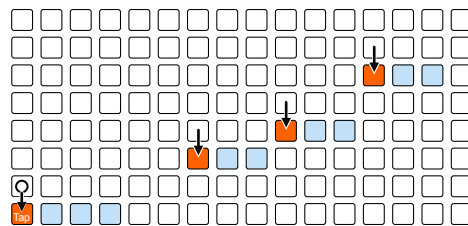

Tapping an empty pad in a column with an existing chord above or below will transpose all notes relative to the chord in the same column.

Tap Pad tapped    ↓ ↑ Direction transposed    Existing notes    Reference / original note position

### Pick & Place Chords

The last chord selected in keyboard view can be placed in the sequencer grid. This is an iterative process switching between keyboard view to audition and select a chord from the library of options and then back to the sequencer view to place the chord into a pattern and build progressions. Holding the [Keyboard] button will temporarily switch to the keyboard view where a chord can be selected. Releasing the [Keyboard] button will switch back to sequencer view and tapping a pad will place the chord into the selected grid step.

#### —Note—

Any existing step notes that are not visible in the current pad range will be indicated in the top or bottom row of the grid to indicate that notes exist off the grid in the indicated column. Scrolling the octave range will bring these notes into view.

# 6 Modes

## Keyboard View & Chord Palette

When in chord mode, keyboard view offers a set of tools for playing, composing and performing with chords. An extension to the classic keyboard chord view is the chord palette, adding more flexibility and aids to chord management. Select keyboard view in a chord sequencer by pressing the [Keyboard] button. The last chord played will be remembered and can then be placed into the grid in sequencer view. Also a collection of user chords can be built directly in keyboard view and then can be used for performing and recording a progression.



Press [Keyboard] button to select or deselect keyboard view.

### Keyboard View - Chord Palette OFF \*

\* Major scale illustrated.

Functions explained also apply with chord palette set to On

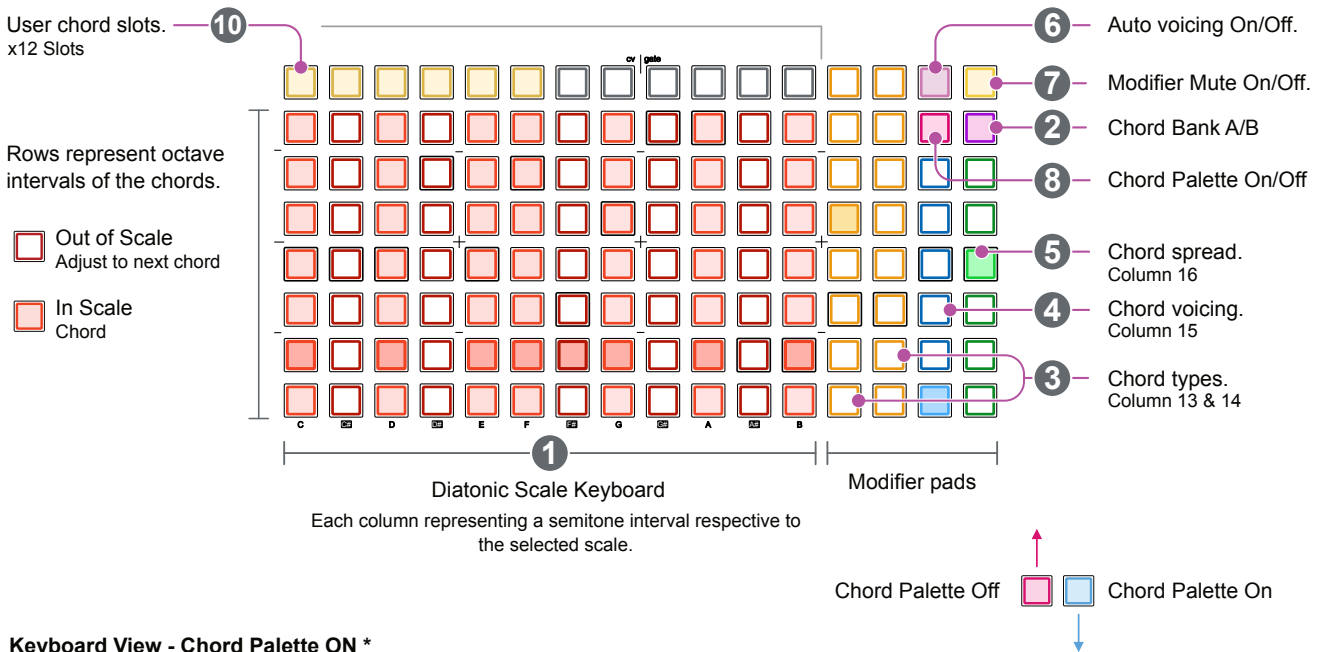

### Keyboard View - Chord Palette ON \*

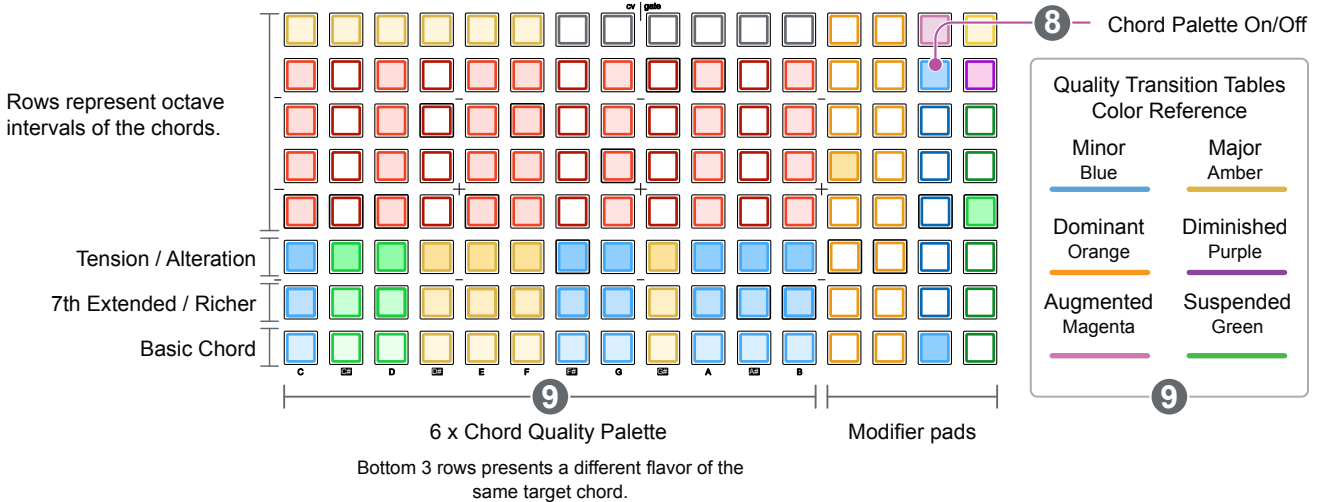

The keyboard view presents chord columns and a chord playback interface. The same functions and options exist when extending the mode to the chord palette where additional chord options are presented. These modes enable a creative environment for developing chord progressions without too much need for musical theory.

- 1 Play chord.**  
Select keyboard [Pad].



Tapping any pad in a column will trigger the chord. Chord layout is based on the current scale and root.
- 2 Choose chord bank A/B.**  
Tap [Pad] to toggle A or B.

A Magenta  B Purple

Tapping the pad will switch between the chord banks A, purple or B, Magenta. The display will indicate the bank selected.
- 3 Select chord type.**  
Tap [Pad] - Column 13 or 14.



Any pad in column 13 or 14 will select the chord type based on the keyboard played scale and root.
- 4 Select voicing.**  
Tap [Pad] - Column 15.



Pads on rows 1-7 from column 15 will select the voicing / inversions for a played chord.
- 5 Select spread.**  
Tap [Pad] - Column 16.



Pads on rows 1-6 from column 16 will select the voicing spread to add higher octave notes to the played chord.
- 6 Auto voicing On/Off**  
Tap [Pad].

Off Red  Auto White

Tap any pad to select auto voicing on/off. On sets chord inversions automatically for smooth chord movement.
- 7 Modifier Unmute/Mute.**  
Tap [Pad] - Column 16, top.

Unmuted Yellow  Muted Pink

Tapping the modifier pad will toggle the audible preview for columns 13-16 on or off.
- 8 Chord Palette On or Off.**  
Tap [Pad].

Off Magenta  On Blue

Tapping the pad will switch the extended chord palette on or off, reverting to the classic keyboard view.
- 9 Play Chord Quality Palette.**  
Tap [Pad].



Pads in the bottom 3 rows play a variant of the target chord, giving a different musical flavour.

## Chord Quality Palette

The bottom 3 pad rows represent the quality aware tables. This means that chords are clustered into table groups that have a musical relationship, meaning they sound good together. The brighter the pads the higher tension, increasing up in rows from the basic chord. The colors of the groups represents the chord quality, amber for major, blue for minor, orange for dominant, purple for diminished, magenta for augmented and green for suspended. This feature is an aid to building melodic phrases and progressions without referring to music theory.

## Chord Banks

Chord bank A covers the more typical and simple chord options allowing a quick start in developing progressions. Chord bank B covers more dissonant chords like augmented, diminished and dominant chords. These are more complex and require more knowledge of musical theory to get the best from these options when building progressions. Its safe to say that with less experience of the theory of musical structures, bank A is the better place to get started.

Supported scales are the 7 diatonic scales: Major, Minor, Dorian, Phrygian, Lydian, Mixolydian, Locrian, Pentatonic Major & Minor, Harmonic Minor and Melodic Minor - ascending.

## User Chord Slots

User slots are available in keyboard view which store up to 12 chords, captured from playing the keyboard. The root note, type, spread and voicing / inversion are all saved with the chord in one of the selected chord slots. These can then be played back as a predefined progression or melody and can also be used to record into the sequencer or played with the arpeggiator. Holding chords plays in legato.

- 10 User chord slots.**  
Empty or used.

Used

Free

Empty slots are shown unlit. Slots with a stored chord will be lit yellow.
  
- Assign chord to a slot.**  
Hold chord [Pad] + slot [Pad].

+

2 sec

To assign a chord and settings, hold the keyboard pad for the chord and hold a slot for > 2 seconds. Message will display when the slot is assigned.
  
- Clear chord slot.**  
Hold chord [Pad] + slot [Pad].

+

4 sec

To clear a chord and settings, hold any keyboard pad and hold the slot pad for > 4 seconds. Message will display when the slot is cleared.
  
- Chord [Pad] + [Shift] + Clear.

+

Shift

+

Hold the user chord pad, then shift + clear to clear the chord slot.
  
- Play chord slot.**  
Tap or hold slot [Pad].

To play the chord from the assigned chord slot, press [Pad] for the respective slot. Playing an empty slot will display a 'Free slot!' message.

The last chord played in [Keyboard] view can be placed into a step in sequencer view using the pick and place process.

Example of assigned slot chords

1	2	3	4	5	6	7	8	9	10	11	12
Cmin - No Inv	D#major - I Inv	Fminor - I Inv	Fminor - II Open	Dminor - Open Voic	Dminor 11 - II Inv	D#mar 11#5 - II Open	Dm add9 - II Open				

### External Keyboard with Chord Sequencer

An external MIDI keyboard can be used to play and capture chords in Keyboard / Chord Palette mode. Chord played will be received on any channel along with its anchor by the ONE and will refresh live in Chord mode.

**Capture a chord.**  
Hold chord [Pad].



In keyboard mode, Hold the user chord pad, then play a chord on the external keyboard

This method also can be applied in Poly sequencer mode.

**Clear a chord.**



Hold the user chord pad, then shift + clear to clear the chord slot.

# 6 Modes

## Chord Arpeggiator

CH

Chord mode has a dedicated arpeggiator which uses the notes from the sequenced chords or chords played in chord keyboard view as the source from which to create an arpeggio instead of the global keyboard. Access to the chord arp is made using the [Arp] button in a chord sequencer. The chord arp is integral to the chord mode engine but still follows the general principles and functionality as the keyboard arpeggiator.

The sequencer must be playing to play chords using the arp.

### Accessing the Chord Arp

#### Select the Chord Arp Options.

Tap [Arp].



Tap [Arp] to select. Hold to temporary view arp options. Grid must be in chord mode and sequencer view. If in keyboard view, only the generic keyboard arp is selected.

S.Arp OFF				1/2
Type	OctV	Accnt	Div	
ON	0	+0%	1/16	
Rot	Len	Puls	Rept	
+0	1	1	0	



Tap (Knob) of the respective parameter to toggle between the upper or lower option for editing.

Corner tagged parameters can be modulated.

SEQ Arp				2/2
GTime	Grov	Reset	-	
0%	Grv 1	ON	-	



Tap [Page] button to cycle through the arp pages. Page button flashes when pages are available.

Chord Arp Parameters				Page 1/2
<b>Type</b>	<b>OctV</b>	<b>Accn</b>	<b>Div</b>	
Off / On - Arp algorithm	Octave voicing range	Velocity accent	Time division	
Sets the arp direction and style for the musical phrase.	Introduces a number of octave higher or lower notes into the arpeggio.	Varies the note velocity based on the 'Grov' groove template.	Sets the arp specific time intervals. This can be different to the sequencer.	
<b>Rotate</b>	<b>Len</b>	<b>Puls</b>	<b>Rept</b>	
Euclidean rotation	Euclidean phrase length	Euclidean pulses	Euclidean pulse repeats	
Rotates the Euclidean pulses + right or - left.	Sets the total length of the Euclidean phrase.	Number of pulses in the Euclidean generator.	Generates repeats for pulses in the Euclidean generator.	

Chord Arp Additional Parameters			Page 2/2
<b>Gtime</b>	<b>Grov</b>	<b>Reset</b>	
Timing of the groove	Groove Templates	Reset	
Adjusts the velocity timing of the arp notes within the selected groove.	Selects a groove template. These are applied to the velocity profile of the arpeggio.	Resets the arp pattern to start at the beginning when new arp notes are applied.	

### 6.8 Stochastic Sequencer Mode

Stochastic mode is a generative sequencer that doesn't follow the normal pattern creation conventions but uses a random generative engine to create and control evolving patterns. Columns represent notes not steps. Feed the sequencer with notes and apply settings using the grid as a control interface to generate and mutate rhythms and melodic passages. It is important to note that while the grid shows the dynamic playhead movement, this only acts as a visual synchronisation reference for speed and length. The playhead is playing an 'invisible' phrase and has no positional relationship with the visible stochastic grid controls.

Use stochastic mode to experiment and explore generative patterns, lock in those that capture your attention and even copy the captured pattern phrase into a mono, poly or multitrack sequencer for further development.

**Sequencer View:** Example: Major Scale, Root C2

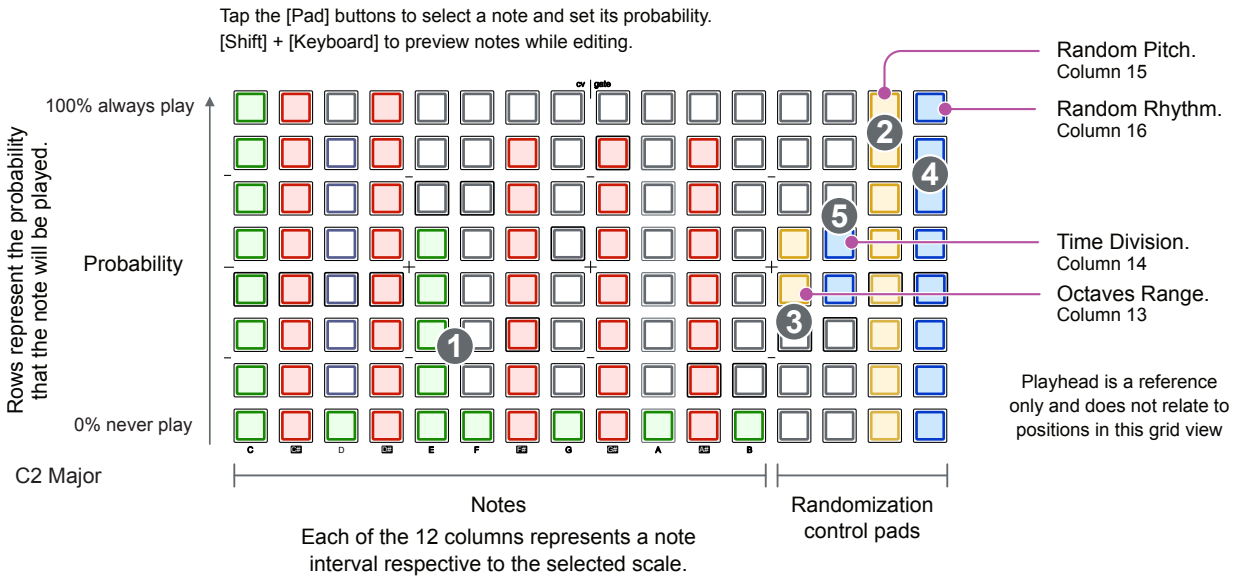

- 1 Set Note Probability.**  
Tap [Pad] - Columns 1-12.

Column pad represent a note value from the scale and the probability that a note will play. The 12 columns represent the available notes (out of scale in red)
- 2 Random Pitch.**  
Tap [Pad] - Column 15.

Sets the number of steps that the pitch randomization engine will affect. 100% - all steps randomized each cycle. 0% - no steps randomized, current phrase is locked in.
- 3 Octave Range.**  
Tap [Pad] - Column 13.

Each pad represents 1 octave up / down the range that the pitch randomization will operate within.
- 4 Random Rhythm.**  
Tap [Pad] - Column 16.

Sets the number of steps that the rhythm randomization engine will affect. 100% - all steps randomized each cycle. 0% - no steps randomized, current phrase is locked in.
- 5 Time Division Range.**  
Tap [Pad] - Column 14.

Sets the range for the time division affected by the randomization engine. Range is from long to short.

## Stochastic Sequencer Architecture

The stochastic term refers to random probability distribution. The same core principles that form ONE's Stochastic sequencer mode. The following illustration will help to understand the sequencer operating model which is a little different in architecture to the others discussed so far. It is important to remember that in this mode, steps are generated and not programmed into a pattern.

Stochastic Sequencer Architecture

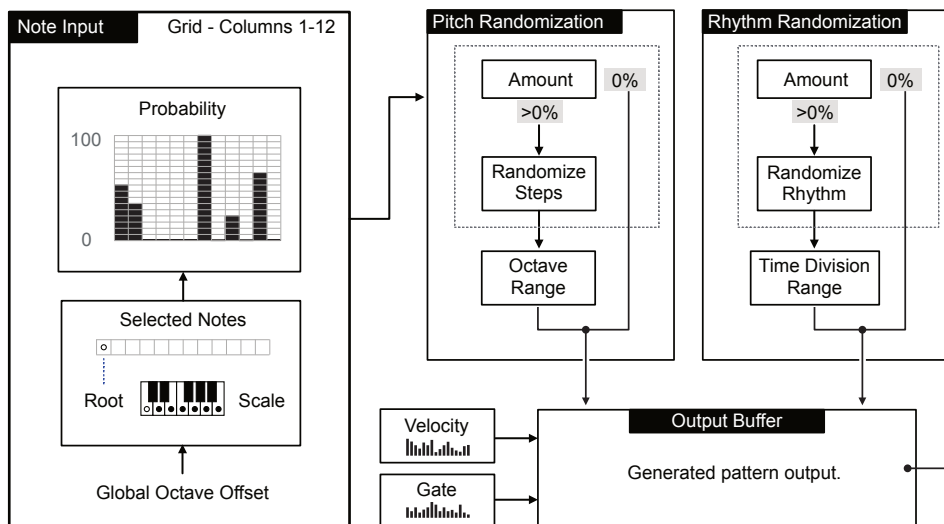



 0% Randomization amount, column 15 & 16, at lowest level effectively stops any new generation and freezes or locks in the existing buffered pitch and/or rhythmic phrase. The existing buffer will play, no new notes.

 >0% Randomization amounts increase the number of steps affected and generate new, random pitch and/or rhythmic phrases. New notes are generated into the buffer.



Velocity and gate affect the notes for each step of the generated pattern. Octave (Oct), Knob 2 affects the global note offset for the entire phrase.



## Pattern Length

The start and end of the generated phrase can be edited in the Stochastic page view or the supplementary velocity and gate pages.



 +  Select the initial first step in the pattern using [Init] + [Pad] for the column that represents the start position. Start and end column positions are lit soft purple while holding Init.

or

 +  Hold [Init] + turn (Knob 2) as an alternative to set the first step.

 +  Select the last step in the pattern using [End] + [Pad] for the column that represents the end step position. Start and end column positions are lit soft purple while holding Init.

or

 +  Hold [Init] + turn (Knob 3) as an alternative to set the last step.

**Stochastic Sequencer Parameters**

Stochastic mode follows the same principles for the sequencer setup, track and step options which have been covered elsewhere in this manual. The main page includes an instant modulation control on knob 4 in place of the standard repeat option. The [Page] button will flash to signify that multiple pages exist. Press [Page] to cycle through the available pages.

**Sequencer Setup Options**

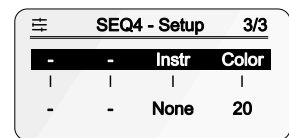
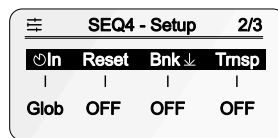
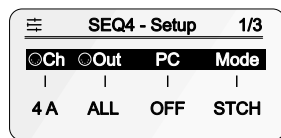

**Track Menu Options.**

Multi mode has a 8 tracks where specific settings can be configured for each by using the track menu options. Each collection of parameter settings in these pages is relevant only for the selected track.

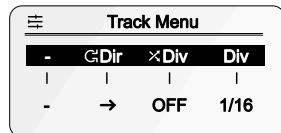

- Ofs.** Base note offset for all notes in the track. Knob 2.
- Div.** Randomisation of time division. Knob 3.
- Dir.** Playback direction for the selected track. Knob 4.

**Step Options.**

Stochastic mode does not have any global or individual step parameters that can be edited.

**Modulation.**

As with all modes, Stochastic includes 8 independent modulation lanes, accessed with the [Mod] button. In addition a quick modulation lane is available using knob 4 'MOD' on the main page.

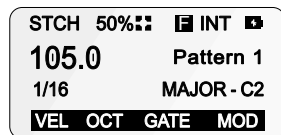

- Push & Turn (Mod) to select a MIDI destination.
- Turn (Mod) to set a global value.
- Tap (Mod) to open the modulation grid lane.

To reset a parameter back to its default setting, press and hold the respective knob for >2 seconds.

## Shifting the Pattern Position

The notes generated can be shifted forwards and back using the arrow buttons.



Shift the generated pattern phrase earlier / left or later / right on the grid by 1 step for each press of the button combo. Only steps within active start / end range are affected.

## Clearing the Generated Pattern

The phrase can be cleared fully using the clear command.



Hold [Shift] + [Paste] to clear the pattern phrase. To fully clear the pattern Hold [Shift] + hold [Paste] for several seconds.

## Velocity & Gate

A velocity value and gate length curve and modwheel can be drawn on the grid in Stochastic mode. Any new patterns generated will follow the velocity profile created. This can be visualised in the velocity view with the follower enabled. This is accessed in stochastic mode by pressing the (Vel) Knob 1 or (Gate), Knob 3 from the main 'home' sequencer page. Turn (Vel) or (Gate) to globally adjust all step values.

Velocity

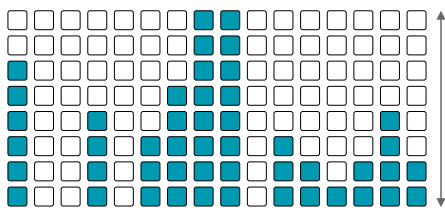

Press Knob 1, (Vel) to select the grid velocity column editor. Swipe across the pads to create a profile.

Turn (Vel) to globally edit the profile.

Gate

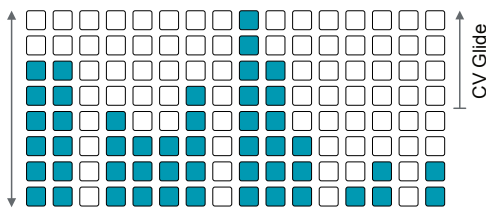



Press Knob 3, (Gate) to select the grid gate column editor. Swipe across the pads to create a profile.



Turn (Gate) to globally edit the profile.



The gate profile also controls the CV glide setting. Any values above 50% will affect the CV glide application.

**Copy, Paste and Clearing Patterns**

A useful option when working in Stochastic mode is the ability to copy a phrase pattern generated in Stochastic mode and pasted into a mono, poly or multitrack sequencer. This is useful when using Stochastic mode as an experimental tool and then developing the ideas further in another sequencer.

 +  To copy from the stochastic sequencer, example copy from 8 to sequencer 1. Hold [Copy] + [8] to copy the stochastic pattern.  
then

 +  To paste to a mono or poly sequencer. Hold [Paste] + [1] to paste the pattern from sequencer 8 into 1. For multitrack sequencers, select the sequencer first then paste into the track using column 1 pads.

 +  To clear the pattern first select the sequencer. Hold [Shift] + Tap [Paste] to clear the pattern. Hold [Shift] + hold [Paste] > 2 seconds to clear the entire sequencer.

## 6.9 Matriceal Sequencer Mode

At first glance the matriceal mode may seem to be a daunting and complex sequencer. However matriceal is not as difficult to master as it first appears, especially with a few tips and guides to get things started.

Matriceal mode is a generative sequencing environment which consists of 4 identical tracks, each with 10 matrices of independent parameters. As a starting point we recommend getting familiar with 4 key principles of the matriceal mode.

### The 4 Golden Principles of the Matriceal Sequencer.

**1 Think in parallel.** There are 10 matrices of parameters each of which is sequenced in its own individual 'lane'. A lane is essentially an independent 16 step sequence of parameter values. Trigger, note and probability for example are decoupled into their own lanes. The lanes operate in the same timeline, in parallel, but can be set to different lengths. This concept is repeated across all 4 tracks.

**2 Individual Journeys.** Each lane of parameters takes its own journey as an independent sequence. Each lane can have its own play direction, time division, start and end points. Playback timing can be synchronised, but the power of matriceal mode comes from having the matrices of parameters operating in different cyclic orbits. Think polyrhythms or polymeters!

**3 Trigger Lane is King.** The primary reference for synchronising the lanes and parameter steps is the trigger lane. Only when the programmed steps in the other 9 parameter lanes coincide with those active steps in the trigger lane will the trigger step parameter change be activated.

**4 More is More.** Other random and probability functions can be overlaid with Matriceal to add to the creative options further. However things can get complex quickly and its easy to lose track - pardon the pun! Start with a small number of steps and expand these as you go, also adding more parameters. Its easier to build up than to get lost in the flow then trying to backtrack.

Track

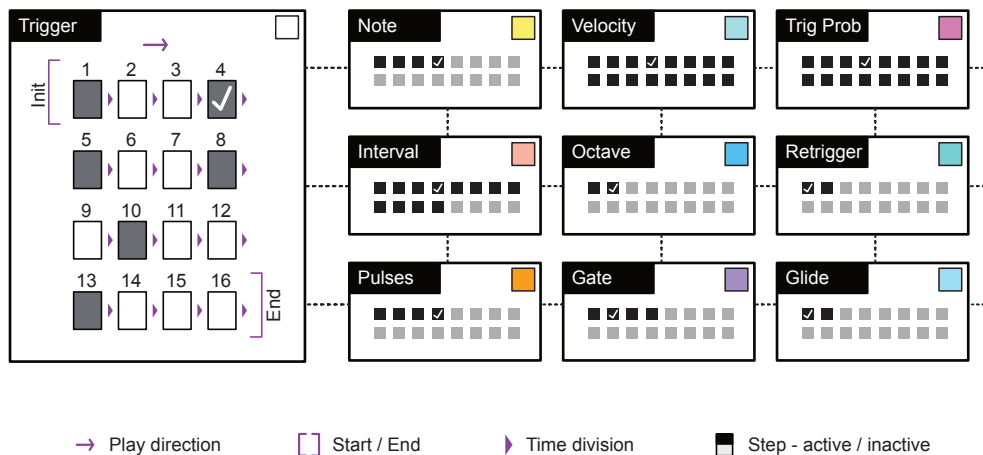

The matriceal layout consists of 4 sections each representing a track. The track sections are identical to each other. The lower row of pads selects each track and also allows muting of each track. The upper section of 16 pads represents the steps in the sequence while the color coded central section gives access to the parameters and lane selection.

**Sequencer View.**

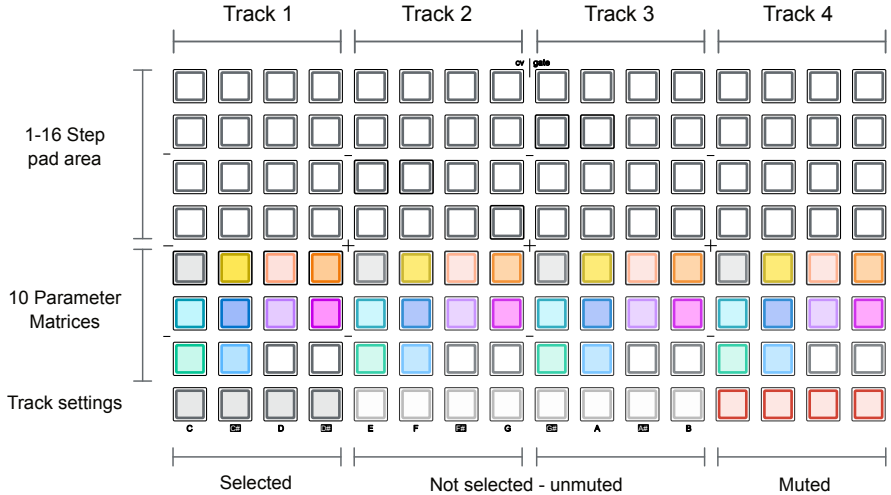

**Track Selection**



Tap any of the 4 bottom row [Pads] to select the respective track. Hold a pad in the bottom 4 to open the selected track settings. All four pads have the same function.

Select Track  Tap any pad in the bottom row of 4 for each track section to select. Selected track lit bright white. Only one track can be selected at a time

Mute Track  +  Hold [Mute] + tap any pad in the bottom row of 4 for each track section to mute.

# 6 Modes

## Parameter Pads



Tap one of the 10 parameter matrices [Pad]s to select its parameter lane. The upper 16 pads represent the parameter sequence. Hold a step [Pad] to edit its parameter settings.

Randomize Matriceal Steps. Hold one of the 10 parameter matrices [Pad]s + tap [Random] to randomise the steps for the matrices. The randomization amount percentage used is set while holding a step and turning knob 4 - 'Rnd'.

Matriceal Parameter Summary	
<b>Trigger</b> Foundation lane - note trigger	<b>Note</b> Pitch variation
Each active step will trigger a note based on the root note and offset. Inactive steps do not trigger events. This is only the trigger and does not set a steps pitch variation. Euclidean and random generators are integrated. This is the primary lead for the other lanes.	Sequences the note value per step. This element is what determines the pitch variation per step, relative to the track note offset value.
<b>Interval</b> Pitch accumulator	<b>Pulses</b> Hold step for pulse duration
Affects pitch of the note. The pitch is increased or decreased in note intervals each time the playhead passes the step. The note value is determined by adding / subtracting the interval with the existing note value.	Holds the active step transport for <u>all parameter lanes</u> for the duration of the pulses selected before continuing to play. The pulse type sets the behavior between triggering only the first pulse, all pulses or tie the pulses.
<b>Velocity</b> MIDI Velocity	<b>Octave</b> Pitch offset
Sets the velocity value for the triggered steps. Default is 75, range is 1-127. As well as the parameter display, the grid will show pads at a brightness level that represents velocity value.	Adds or subtracts an octave offset. Range is +/-4. Probability can also be applied as well as randomization.
<b>Gate</b> Note length	<b>Trigger Probability</b> Chance a step is triggered
The gate length can operate between 2-99% with 50% as the default. Also legato and tie are available options. Brightness of the pad indicates the value set.	Sets the probability that a note trigger will be initiated or not. Range is from 0%, where no events are generated to 100% where a note trigger event will be activated.
<b>Retrigger</b> Note repetitions	<b>Glide</b> CV Glide
Number of note repetitions within the step duration when a new trigger is activated and the probability allows. The option to set to 'skip' is also available, which skips the step in time.	Smooths pitch between notes. Only applied to CV as MIDI does not support glide.

The option to edit the parameter lanes using the full 16 x 8 grid is possible by double tapping the parameter button. This can also be used to set the start and end points of the 16 step pattern as well as change the speed of playback. This does not apply to the trigger lane. The length of the parameter lanes is what brings the surprise to Matriceal. Triggers will evaluate each parameter step but these may vary through playback.

**Parameter Matrices - Grid Column Editor View.**

**Select a Parameter to Edit**  
Double tap [Pad] for the selected parameter.

Tap x 2, Example: Velocity

Back config  
Press [Back] to return to the main sequencer view.

Track selection x4 pads

Lower 16 pads per track

**Grid Column Editor, 16 x 8 Pads**

Tap a column [Pad] to set the step value

Parameter value range

Columns represent 1 - 16 steps

**Lane Length**

Hold [Init] or [End] plus [Pad] column to set the start or end points

**Lane Time Division**

The option to quickly double the sequencer time division from its current value is possible by holding [Shift] + tap [Init].

The option to quickly halve the sequencer time division from its current value is possible by holding [Shift] + tap [End].

## Matriceal Sequencer Track Parameters

The generic details of sequencer setup and track and step options have already been covered, so here is a refresher on the general options. Any unique matriceal mode parameters are described here. The [Page] button will flash to signal if multiple pages exist. Press [Page] to cycle through the available pages.



Page button flashes to signify that multiple pages exist. Tap [Page] to cycle through available pages.

## Sequencer Setup Options



+



The sequencer setup is accessed by holding [Shift] + [1] - [8].

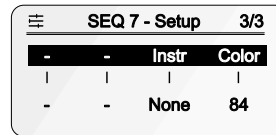
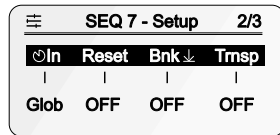
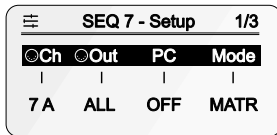

## Track Options.

These parameters are track specific. Example shows track 3 selected, as stated in the page header. To reset a parameter back to its default setting, press and hold the respective knob for >2 seconds. Reset excludes the track selection parameter, Tsel.

### Track Menu Settings.



Matriceal mode has 4 tracks so these settings operate this sequencer mode on a per track basis. Press the [Track] button to access.



Hold one of the four track selection pads for the track while editing the four knob parameters. The quick edit, track menu will open for the selected track.

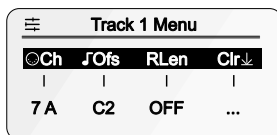

**Ch.** MIDI Channel and port assigned to track. Knob 1.

**Ofc.** Base note for all notes in the track. Knob 2.

**RLen.** Length before resetting the playhead transport. Knob 3.

**Clr.** Tap to clear every parameter on the track. Knob 4.

**RLen** affects all sequencer lanes for the track. The length is measured in trigger lane steps + pulses. The playhead will be restarted for all parameter lanes and the trigger lane when RLen is reached. Think of this as a looping function.

### Matriceal Step Parameters

The matriceal mode has 10 matrices of parameters operating in lanes within each of the 4 sequencer tracks. Each parameter is described in more detail here.

#### Lane Range

Track lane start  
First step

Init **X2** + 

Track lane end  
Last step

End **/2** + 

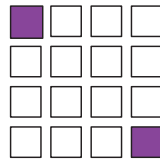



Start and end can be set for each lane in the 16 step section of the track

### Trigger

The trigger lane is important as it is the fundamental reference that determines the behavior of all other parameter lanes. Each time a trigger event is activated in the trigger lane, all other parameter lanes are checked for their parameter value at the same point. The trigger lane and parameter lane, while in sync, may be on a different orbits. The current parameter value at that point in time is then applied at the trigger. For example changing a note pitch for a trigger step. The independent journey of each lanes step cycle is what creates the generative, sometimes unpredictable phrases and melodies. On its own, the trigger lane will output a fixed default note on each active step based on the global parameter values.

#### Trigger Lane Settings

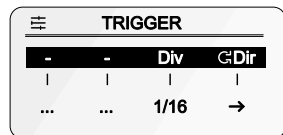

  Hold [Trigger] pad. to select and display the available trigger lane parameter options. The trigger is the first pad in the parameter matrices section. The 16 upper pads now represent the trigger lane steps. Column editor is not available for the trigger lane.



**Div.** Sequence lane time division. Knob 3.

**Dir.** Playback direction for the lane. Knob 4.

 Tap a [Pad] in the upper 16 pad step lane section to manually select or deselect a trigger on the selected step. The [Undo] / [Redo] option is available for trigger step editing.

  Hold any [Pad] in the upper 16 pad lane section to select and display the available parameter options for all of the trigger steps.

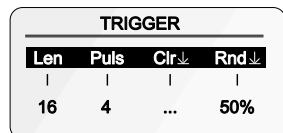

The step menu options parameters apply to all of the trigger steps when editing a trigger lane. The other 9 parameter matrices can be edited per individual step.

Trigger Steps			
Len	Puls	Clr	Rnd
Euclidean seq length	Euclidean seq pulses	Clear all steps	Randomly add triggers
Sets the Euclidean pattern length up to 16 steps. Also affects the 'end' position.	Applies the number of pulses to be applied into the Euclidean pattern set by length.	Tap to clear all steps for the trigger lane.	Randomly assigns triggers into the steps. Tap knob to apply. 100% covers all 16 steps.

# 6 Modes

## Note

The note lane has 16 steps each of which can carry a unique parameter setting. For example a pitch note value to form part of a melody on each step. These note changes apply when the note step coincides with a trigger step. Notes edited here are relative to the note offset found in the track settings.

### Note Lane Settings



Hold [Note] pad to select and display the available note lane parameter options. The 16 upper pads now represent the note lane steps. Optionally double tap to open the column editor for the parameter lane.

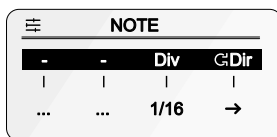

**Div.** Sequence lane time division. Knob 3.  
**Dir.** Playback direction for the lane. Knob 4.

### Note Steps Setting



Hold any [Pad] in the upper 16 pad section to select and display the available parameter options for all of the note steps. Steps are only activated and lit when a new note value is applied.

Notes are relative to the track note offset found in the track settings as 'Ofs'.

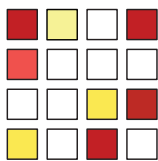

Yellow pads indicate notes higher in pitch than the track note offset. Pad yellow level brightness is higher with higher pitches.

Red pads indicate notes lower in value than the pitch of the track note offset. Pad red level brightness is higher with lower pitches.

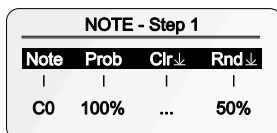

Hold step [Pad] + turn (Knob) for the relevant parameter to edit. Push (Knob) to activate a command.

Note Steps			
Note	Prob	Clr	Rnd
Note pitch	Probability	Clear all steps	Set notes randomly *
Note to apply to triggers. Value is relative to the track note offset. Tap knob to reset the value.	Probability that the note value is applied to the trigger. 0% will only apply the global default.	Tap to clear all steps for the note lane.	Randomly assigns note value into the steps. Tap knob to apply. 100% covers all 16 steps.

\* Rnd is applied to all steps. The value can be changed with any step but applies to all.

Remember that the trigger lane steps govern the sequence and operate in conjunction with other parameters in other lanes in order to develop a pattern. These will also change the final output note value. For example, octave and interval will also apply a value change to the relevant trigger lane steps.

**Interval**

Interval is a similar concept to the accumulator found in the mono mode sequencers. Each time the playhead passes the interval step it will add or subtract to/from the current notes. Played notes are affected by all applied parameters. The interval is based on the current scale. This will create a rise or fall in the pitch value for the subsequent steps through the progression of the track cycles. When the max value is reached it will reset to the min setting. If the pitch decreases it will be reset to max once it reaches the min value. The range for the incremental pitch ramps is -24 to +24 with +/-7 being the default.

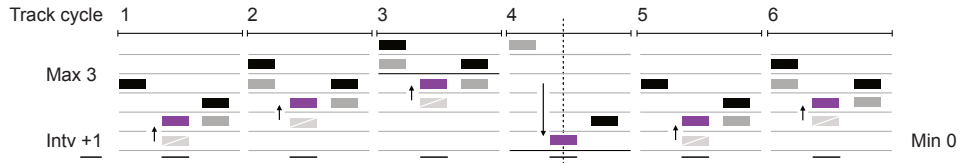

Pitch accumulates at the selected note, affecting all lane notes, on each track cycle in 'Intv' value intervals until reaching max or min position and then resets to the min or max position and restarts the accumulation cycle.

**Interval Lane Settings**



Hold [Interval] pad to select and display the available interval lane parameter options. The 16 upper pads now represent the interval lane steps. Optionally double tap to open the column editor for the parameter lane.

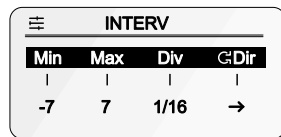

- Min.** Minimum interval limit. Resets to max at this point. Knob 1.
- Max.** Maximum interval limit. Resets to min at this point. Knob 2.
- Div.** Sequence lane time division. Knob 3.
- Dir.** Playback direction for the lane. Knob 4.

**Interval Steps Setting**



Hold any [Pad] in the upper 16 pad section to select and display the available parameter options for all of the interval steps. Interval steps are only activated when a new interval value is applied.

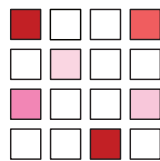

Red pads indicate negative 'Intv' intervals to decrement the pitch of the note. Pad red level brightness is higher with larger interval settings. Limit is -12.

Pink pads indicate positive 'Intv' intervals to increment the pitch of the note. Pad pink level brightness is higher with larger interval settings. Limit is 12.

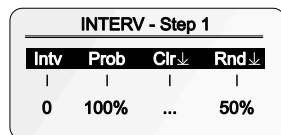

Hold step [Pad] + turn (Knob) for the relevant parameter to edit. Push (Knob) to activate a command.

Interval Steps			
Intv	Prob	Clr	Rnd
Note Interval in the scale	Probability	Clear all steps	Set notes randomly *
Interval that the step will increment or decrement on each transport cycle.	Probability that the note value is accumulated to the trigger. 0% will play with no accumulation.	Tap to clear all steps for the interval lane.	Randomly assigns Intv values into the steps. Tap knob to apply. 100% covers all 16 steps.

\* Rnd is applied to all steps. The value can be changed with any step but applies to all.

# 6 Modes

## Pulses

Sets the amount and type of pulses to hold for the current step before progressing the transport to the next step. Effectively repeating the step triggers. While the step is held by the pulses function it will reflect the held duration across all other parameter lanes. The pulse type sets the behavior options of the pulses from triggering only the first pulse, triggering all pulses in sequence or to tie the pulses together.

### Pulse Lane Settings



Hold [Pulses] pad to select and display the available pulse lane parameter options. The 16 upper pads now represent the pulse lane steps. Optionally double tap to open the column editor for the parameter lane.

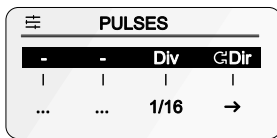

**Div.** Sequence lane time division. Knob 3.  
**Dir.** Playback direction for the lane. Knob 4.

### Pulse Steps Setting

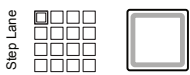

Hold any [Pad] in the upper 16 pad section to select and display the available parameter options for all of the pulse steps. Steps are only activated when a new pulse value is applied above 1.

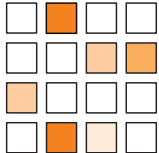

Orange pads indicate number of pulses. The higher the pulse count the brighter the pad is lit. Maximum pulses is 9. Note that steps and pulses are counted in total when calculating the RLen track setting state.

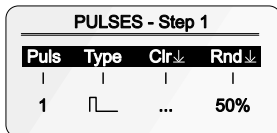

Hold step [Pad] + turn (Knob) for the relevant parameter to edit.  
 Push (Knob) to activate a command.

Pulses Steps				
Puls	Type	Clr	↓	Rnd
Number of pulses	Repeat play behavior	Clear all steps		Set notes randomly *
Number of repeats to hold the step duration. Puls >1 affects the RLength calc.	Plays the first pulse, plays all pulses or ties the pulses to extend a note. See below.	Tap to clear all steps for the pulses lane.		Randomly assigns pulse values into the steps. Tap knob to apply. 100% covers all 16 steps.

\* Rnd is applied to all steps. The value can be changed with any step but applies to all.

### Type



Plays only first note in pulse sequence.



Plays all notes in pulse sequence.



Ties all notes in pulse sequence.

**Velocity**

Sets the MIDI velocity for the step triggers. The velocity range is set from 1-127 with a default applied across all steps of 75.

Velocity Lane Settings

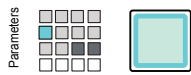

Hold [Velocity] pad to select and display the available velocity lane parameter options. The 16 upper pads now represent the velocity lane steps. Optionally double tap to open the column editor for the parameter lane.

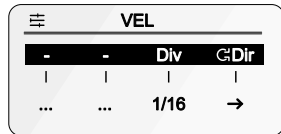

**Div.** Sequence lane time division. Knob 3.  
**Dir.** Playback direction for the lane. Knob 4.

Velocity Steps Setting

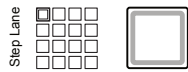

Hold any [Pad] in the upper 16 pad section to select and display the available parameter options for all of the velocity steps. Steps are only activated when a new velocity value is applied.

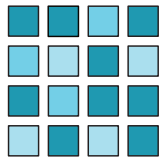

Brightness of pad colors will represent the velocity value applied. Brighter pads indicate higher velocity values.

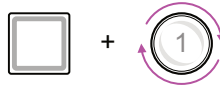
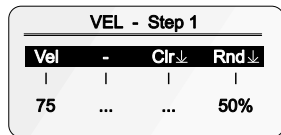

Hold step [Pad] + turn (Knob) for the relevant parameter to edit.  
 Push (Knob) to activate a command.

Velocity Steps			
Vel		Clr	Rnd
Velocity level		Clear all steps	Set notes randomly *
Sets the step MIDI velocity between 1-127.		Tap to clear all steps for the velocity lane.	Randomly assigns pulse values into the steps. Tap knob to apply. 100% covers all 16 steps.

\* Rnd is applied to all steps. The value can be changed with any step but applies to all.

# 6 Modes

## Octave

Selects a wider range for note generation by adding octave offsets. Notes can be generated across the range. It is also possible to select a probability value to apply, or not apply the octave offset per step.

### Octave Lane Settings



Hold [Oct] pad to select and display the available octave lane parameter options. The 16 upper pads now represent the octave lane steps. Optionally double tap to open the column editor for the parameter lane.

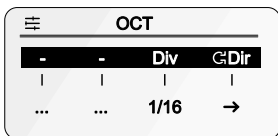

**Div.** Sequence lane time division. Knob 3.  
**Dir.** Playback direction for the lane. Knob 4.

### Octave Steps Setting



Hold any [Pad] in the upper 16 pad section to select and display the available parameter options for all of the octave steps. Steps are only activated when a new octave value is applied.

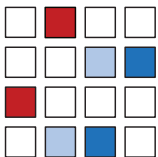

Blue pads indicate positive octave settings, greater than 0. Brighter pads indicate a higher range, maximum 4.

Red pads indicate negative octave settings, glower than 0. Brighter pads indicate a lower range, maximum -4.

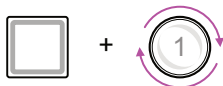
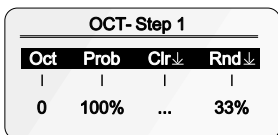

Hold step [Pad] + turn (Knob) for the relevant parameter to edit. Push (Knob) to activate a command.

Pulses Steps			
Oct	Prob	Clr	Rnd
Octave Offset	Probability	Clear all steps	Set notes randomly *
Sets the octave offset for the selected step between -4 to +4.	Sets the chance that the offset is applied to the selected step. 100% will always apply oct offset.	Tap to clear all steps for the octave lane.	Randomly assigns pulse values into the steps. Tap knob to apply. 100% covers all 16 steps.

\* Rnd is applied to all steps. The value can be changed with any step but applies to all.

**Gate**

Sets the note length for each step. A gate of 50% will output a note half of the time division. Range is between 2-99%. The option to set a tie to cover consecutive triggers into a single note is available. Also a legato option can be selected which overlaps the following note by using a note on message earlier than the current note off. Legato will seamlessly transition across, rather than step between notes. To access these options select a value above 99%.

Gate Lane Settings



Hold [Gate] pad to select and display the available gate lane parameter options. The 16 upper pads now represent the gate lane steps. Optionally double tap to open the column editor for the parameter lane.

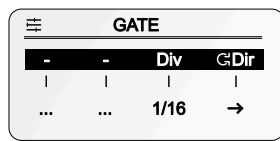

**Div.** Sequence lane time division. Knob 3.  
**Dir.** Playback direction for the lane. Knob 4.

Gate Steps Setting

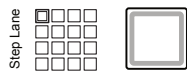

Hold any [Pad] in the upper 16 pad section to select and display the available parameter options for all of the gate steps. Steps are only activated when a new gate value is applied.

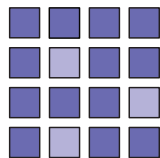

Pads are purple. Brightness of pad colors will represent the gate note length value applied. Brighter pads indicate higher gate values.

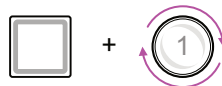
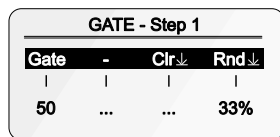

Hold step [Pad] + turn (Knob) for the relevant parameter to edit.  
 Push (Knob) to activate a command.



Gate Steps		
Gate	Clr	Rnd
Gate length	Clear all steps	Set notes randomly *
Sets the step note length in time division % or tie or legato.	Tap to clear all steps for the gate lane.	Randomly assigns pulse values into the steps. Tap knob to apply. 100% covers all 16 steps.

\* Rnd is applied to all steps. The value can be changed with any step but applies to all.

## Trigger Probability

Trigger probability refers to the chance of a step being triggered or not. The higher the probability, the more chance it will trigger. A 0% setting mean the trigger is not activated at all and 100% will always trigger the step. The trigger probability parameter is a dedicated lane of steps that control the main trigger lane. When the steps between the lanes coincide the resultant output, trigger or no trigger, is generated.

### Trigger Probability Lane Settings

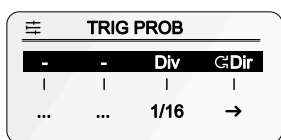

  Hold [Oct] pad to select and display the available trigger probability lane parameter options. The 16 upper pads now represent the trigger probability lane steps. Optionally double tap to open the column editor.



**Div.** Sequence lane time division. Knob 3.

**Dir.** Playback direction for the lane. Knob 4.

### Trigger Probability Steps Setting

  Hold any [Pad] in the upper 16 pad section to select and display the available parameter options for all of the trigger probability steps. Steps are only activated when a new probability value is applied below the default 100%.

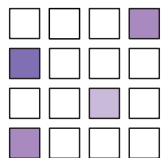

Pads are unlit at 100%. Purple pads refer to values below 100% and the brightness of the pad refers to the value. Brighter pads mean lower value / lower probability.

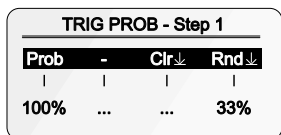

Hold step [Pad] + turn (Knob) for the relevant parameter to edit.  
Push (Knob) to activate a command.

Trigger Probability Steps			
Prob		Clr	Rnd
Probability		Clear all steps	Set notes randomly *
Sets the chance that the equivalent, active trigger lane step is triggered.		Tap to clear all steps for the trigger probability lane.	Randomly assigns pulse values into the steps. Tap knob to apply. 100% covers all 16 steps.

\* Rnd is applied to all steps. The value can be changed with any step but applies to all.

**Retrigger**

Retrigger applies a number of note repetitions within the same step duration when the retrigger lane steps coincide with trigger steps. The sequence maintains its synchronisation and speed. Up to 6 repeats are available along with a 'skip' option. Repeat default is 1, meaning no retriggers.

Retrigger Lane Settings

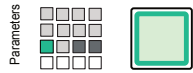

Hold [Retrig] pad to select and display the available retrigger lane parameter options. The 16 upper pads now represent the retrigger lane steps. Optionally double tap to open the column editor for the parameter lane.

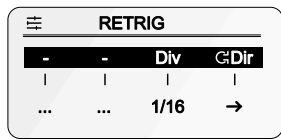

**Div.** Sequence lane time division. Knob 3.  
**Dir.** Playback direction for the lane. Knob 4.

Retrigger Steps Setting

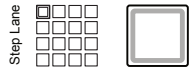

Hold any [Pad] in the upper 16 pad section to select and display the available parameter options for all of the retrigger steps. Steps are only activated when a new retrigger value is applied.

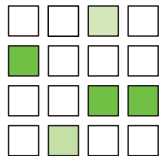

Pads are off when 1 retrigger is set, the default. The pads are green when a retrigger is set above 1, the brightness of the pad color will represent the retrigger value applied. Brighter pads indicate higher retrigger values.

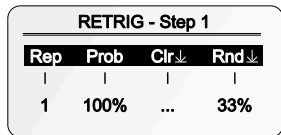

Hold step [Pad] + turn (Knob) for the relevant parameter to edit. Push (Knob) to activate a command.

Gate Steps			
Rep	Prob	Clr	Rnd
Repeats	Probability	Clear all steps	Set notes randomly *
Number of repeats applied when the step is triggered. 1 is the default single trigger	Sets the chance that a retrigger will occur. 100% means always, 0% means no repeats.	Tap to clear all steps for the retrigger lane.	Randomly assigns pulse values into the steps. Tap knob to apply. 100% covers all 16 steps.

\* Rnd is applied to all steps. The value can be changed with any step but applies to all.

# 6 Modes

## Glide

Glide creates a smooth transition between notes. Glide applies to CV outputs only and is not supported by MIDI protocols. Default is 0 meaning no glide while the option to set a value up to 100 is possible.

### Glide Lane Settings



Hold [Oct] pad to select and display the available glide lane parameter options. The 16 upper pads now represent the glide lane steps. Optionally double tap to open the column editor.

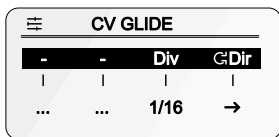

**Div.** Sequence lane time division. Knob 3.  
**Dir.** Playback direction for the lane. mKnob 4.

### Glide Steps Setting



Hold any [Pad] in the upper 16 pad section to select and display the available parameter options for all of the glide steps. Steps are only activated when a new glide value is applied above 0.

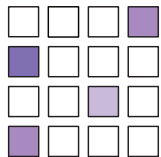

Pads are unlit at 0. Light blue pads refer to values above 0 and the brightness of the pad refers to the value. Brighter pads mean higher glide values.

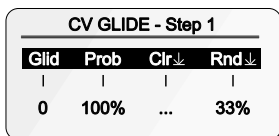

Hold step [Pad] + turn (Knob) for the relevant parameter to edit.  
 Push (Knob) to activate a command.

Trigger Probability Steps			
Glid	Prob	Clr	Rnd
Glide CV Output	Probability	Clear all steps	Set notes randomly *
Amount of glide applied when the step coincides with the trigger lane step.	Sets the chance that the glide value is applied to the equivalent trigger step.	Tap to clear all steps for the glide lane.	Randomly assigns pulse values into the steps. Tap knob to apply. 100% covers all 16 steps.

\* Rnd is applied to all steps. The value can be changed with any step but applies to all.

## 6.10 Domino Sequencer Mode

Domino is a trigger layered sequencer with independent, but synchronized, trigger and note layers. The trigger section consists of up to 64 steps and is populated with triggers that will then control the 32 steps of the note section. Each trigger that is activated in the trigger section drives the position of playback in the note section. The note section therefore generates a melodic or beat phrase at the sequencer output using the independent rhythmic nature of the trigger layer. Domino can operate in Mono or Poly mode.

### The Domino Grid Sequencer

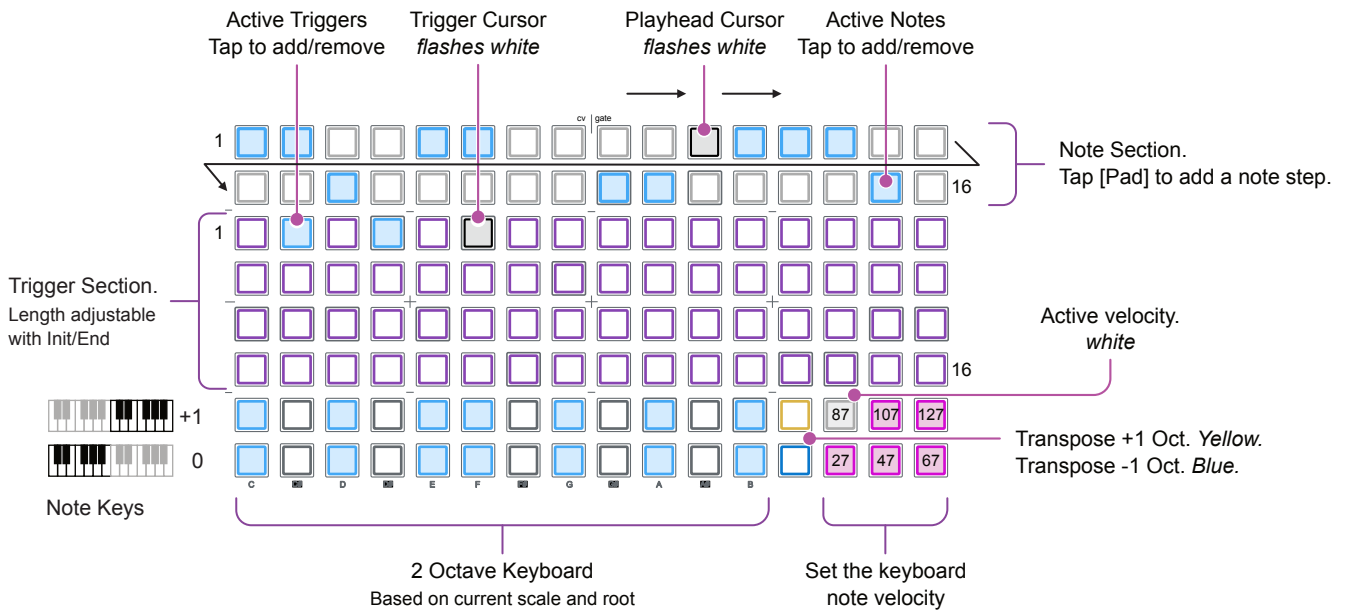

Pressing [Keyboard] will present the full keyboard mode onto the pads. Tap [Mod] to access all 8 modulation lanes.

### Creating a Sequence

**Select the Sequencer.**  
Quickly tap [Pad].



Select the sequencer, Tap sequencer pad [1] - [8]. Set the sequencer mode to 'Domino'.

**Trigger Section length.**  
[Init] or [End]



The [Init] and [End] buttons will display the start/end locators of both the note and trigger sections. Tap the step pads to locate the purple start and end markers on either section while holding the Init/End buttons.

**Add / Remove a Trigger.**  
Tap a trigger pad.



Tap a, dark purple trigger section [Pad] to activate or deactivate a trigger step. Active steps are brightly lit in the sequence color.

**Add Note or Chord.**  
Hold [Pad] + Press Note.





Hold an unlit, empty step [Pad] in the note section + tap the keyboard note or play a chord with up to 4 notes to apply it to the step.

## 6 Modes

### Domino Sequencer Parameters

The generic details of the sequencer setup, track and step options have been covered elsewhere in this manual. Here is a summary of the options for the Domino mode sequencer. The [Page] button will flash to signify that multiple pages exist. Press [Page] to cycle through the available pages. Hold a knob to reset its parameter to default.

### Sequencer Setup Options

 +  The sequencer setup is accessed by holding [Shift] + [1] - [8].

SEQ6 - Setup 1/3			
Ch	Out	PC	Mode
6 A	ALL	OFF	DOMI

SEQ6 Setup 2/3			
In	Reset	Bnk ↓	Trmsp
Glob	OFF	OFF	OFF

SEQ6 Setup 3/3			
Voice	ChMx	Instr	Color
Poly	OFF	None	70

**Voice.** The voice option will switch between 'Mono' and 'Poly'. Typically you can use mono for single note phrases, maybe percussion applications, while poly, the default, is used for chords and multiple voice applications.

**ChMx.** Channel Multiplexing. The ChMx setting will redistribute the active voices, typically created from a chord, to the other incremental MIDI channels, upwards from the base. The current sequencer channel is the 'base' starting point. When set to an option other than off, it is applied to all chords in the sequence.

The options other than Off, are 2Lo to 8Lo and 2Hi to 8Hi. Hold (ChMx) knob to switch between Lo and Hi options. With channel multiplexing on, the following behavior applies:-

Lo represents the lowest note in a chord. The lowest note always remains on the base MIDI channel. Each of the chords other notes will be directed individually, in increasing pitch order, to the consecutive MIDI channels. Notes are spread over channels based on the Lo span number selected. At the end of the Lo range the next note will wrap back to the base and the cycle continues.

Hi represents the Highest note in a chord. The highest note always remains on the base MIDI channel. Each of the chords other notes will be directed individually, in decreasing pitch order, to the consecutive MIDI channels. Notes are spread over channels based on the Hi span number selected. At the end of the Hi range the next note will wrap back to the base and the cycle continues.

Example: 2 notes (C4, G4), Base sequencer channel = Ch 1 and span = 2:

- 2 Lo: C4 is sent to Base MIDI Channel 1, G4 is sent to MIDI Channel 2.  
If the chord had a third higher note, should it exist, it will wrap back to the base channel
- 2 Hi: G4 is sent to Base MIDI Channel 1, C4 is sent to MIDI Channel 2.  
If the chord had a third lower note, should it exist, it will wrap back to the base channel

### Track Menu Options.

 Domino mode has a single track so these settings operate globally for this sequencer mode. Press the [Track] button to access. Hold a knob to clear/reset the value.

Track Menu			
-	Dir	×Div	Div
-	→	OFF	1/16

**Dir.** Playback direction. Knob 2.

**Div.** Randomisation of time division. Knob 3.

**Div.** Sequencer time division. Knob 4.

**Step Pages.**

Some step parameters can be edited globally, covering all steps. Active steps can be edited individually. Multiple steps can also be edited collectively by holding more than one pad simultaneously.

**Global Step Parameters**



Global - Press [Step]

Step/Accl Global			
Rept	Durat	...	
...	...	...	...
Offst	AcmM	-	-
...	Step		

Tap (Knob) for the selected parameter to edit in order to switch between the upper or lower options in a dual parameter row display.

**Individual Note Step Parameters**



Individual Step\* - Hold note step [Pad] +



[Page] to cycle through pages.

Stp1	J C2	1/3	
Vel	Note	Gate	Trig
75	C2	50	100%

Stp1	Submenu			2/3
Rept	Durat	...		
No	x 1	±0%	±0%	
Offst	CvGld	JRng	Rpt%	
0%	0	0st	100%	

Stp1	Accum			3/3
Amt	Mode	Acml+	Acml-	
+0st	Wrap	+7st	-0st	
Total	Trig	%Mde	Acm%	
+0st	All	Iqnor	100%	

**Individual Trigger Step Parameters**



Individual Step\* - Hold trigger step [Pad]

Trigger - Step 2			
Rept	Durat	Rpt%	
2	x 1	100%	±0%
-	-	-	Trig
-	-	-	100%

\* Multipress is also possible for multiple step edits along with the step range selection method.

# 6 Modes

## Operating Behavior.

In simple terms, the note track will play the melodic or beat pattern based on the steps and notes/chords applied. The transport and iteration of the note steps is controlled by the trigger section. Each time a trigger or a trigger repeat is activated, the note sequence will move forward one step per trigger/repeat.

The generative and unpredictable nature offers a unique experience in pattern creation, especially when applying different lengths, repeats, logic and conditions between the note and trigger sections and using the note section accumulator and more advanced repeats. When applying chords, ensure the sequencer voice setting is set to Poly mode.

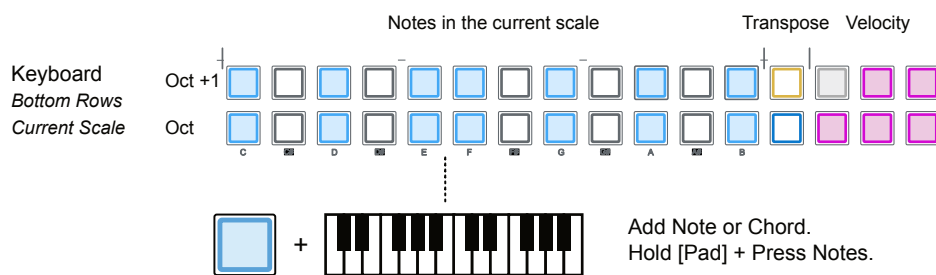
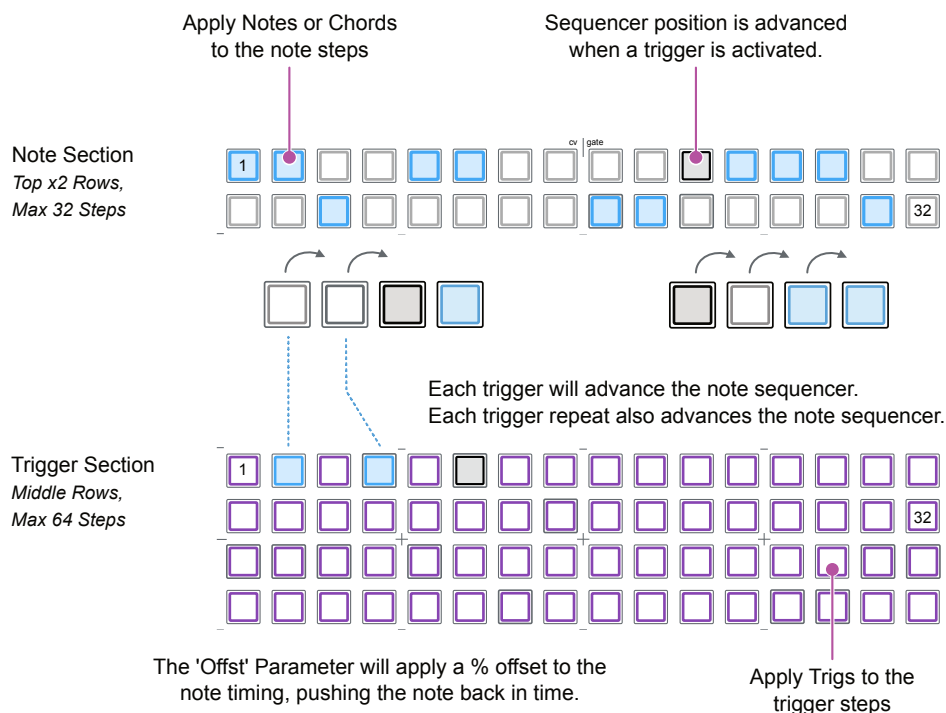

The keyboard allows notes or chords, in poly mode, to be played and applied to steps in the note sequencer section. This is a 2 Octave range, based on the current scale and root and offers transposition and velocity setting.

Both the note and trigger section layers have the ability to apply advanced sequencing techniques. This allows a complex yet creative environment for sequence generation. The random step generator is not available in this mode.

### 6.11 Saga Sequencer Mode

Saga is a duration based step sequencer. Unlike standard step sequencers which play to a fixed grid, Saga operates with individual step lengths. This offers an interesting creative environment where steps can play polyphonic chords or notes at different durations, allowing uneven, yet musically expressive sequences without the constraints and rigidity of the fixed grid.

When working with Saga think of each step, represented by individual pads, as hosting a 'stage' in the sequence. A stage is a set of parameters and notes which operates with its own duration. Each stage time is controlled by the duration, set in steps and which affects the overall sequence duration. The interface is a single page of grid pads with each pad representing a stage. The sequence is arranged top left pad, stage 1, counting up to the right to Stage 16, then continues with stage 17 on the first column, next row down and so forth.

#### The Saga Grid Sequencer

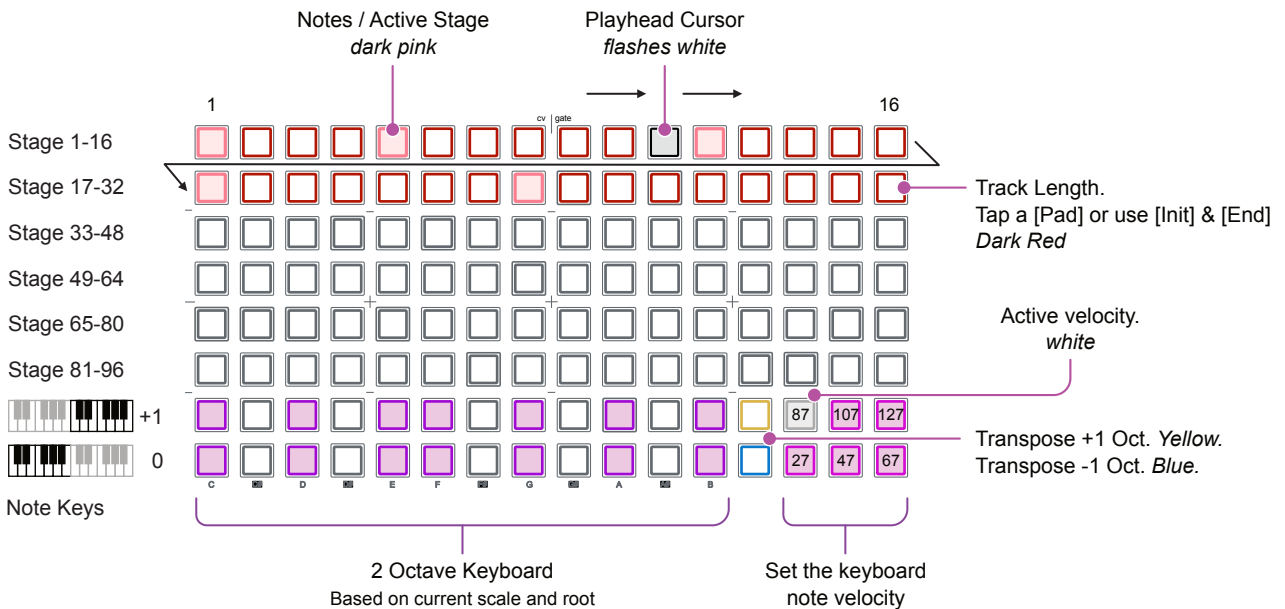

Pressing [Keyboard] will present the full keyboard mode onto the pads. Tap [Mod] to access all 8 modulation lanes.

#### Creating a Sequence

##### Select the Sequencer.

Quickly tap [Pad].



Select the sequencer, Tap sequencer pad [1] - [8]. Set the sequencer mode to 'Saga'.

##### Set the length.

Tap empty [Pad].



Tap an empty pad to set the length of the sequence. Each pad represents a stage of the sequence and length is show with deep red pads. Also use [Init] to set the start and [End] to select the last stage.

##### Activate a Stage.

Tap a red [Pad].

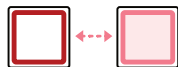

Tap a red [Pad] within the active stage with the default note. Tap again to toggle the stage off. Active stages are pink. Stages and their settings will create the melodic phrase in the sequence.

##### Add Note or Chord.

Hold [Pad] + Press Note.





Hold a red, empty [Pad] + tap the keyboard note or play a chord. This will be applied to the stage chosen with the pad. Ensure the sequencer voice setting, found on page 3, is set to 'Poly' in order to apply chords.

# 6 Modes

## Saga Sequencer Parameters

The generic details of the sequencer setup, track and step options have been covered elsewhere in this manual. Here is a summary of the options for the Saga mode sequencer. The [Page] button will flash to signify that multiple pages exist. Press [Page] to cycle through the available pages. Hold a knob to reset its parameter to default.

### Sequencer Setup Options

 +  The sequencer setup is accessed by holding [Shift] + [1] - [8].

SEQ6 Setup 1/3			
Ch	Out	PC	Mode
6 A	ALL	OFF	SAGA

SEQ6 Setup 2/3			
In	Reset	Brk	Trnsp
Glob	OFF	OFF	OFF

SEQ6 Setup 3/3			
Voice	ChMx	Instr	Color
Poly	OFF	None	70

**Voice.** The voice option will switch between 'Mono' and 'Poly'. Typically you can use mono for single note phrases, maybe percussion applications, while poly, the default, is used for chords and multiple voice applications.

**ChMx.** Channel Multiplexing. Hold (ChMx) knob to switch between Lo and Hi options. The ChMx setting will redistribute the active voices, typically created from a chord, to the other incremental MIDI channels, upwards from the base. See Domino sequencer for expanded details.

### Track Menu Options.

 Saga mode has a single track so these settings operate globally for this sequencer mode. Press the [Track] button to access. Hold a knob to clear/reset the value.

Track Menu			
-	Dir	×Div	Div
-	→	OFF	1/16

- Dir.** Playback direction. Knob 2.
- Div.** Randomisation of time division. Knob 3.
- Div.** Sequencer time division. Knob 4.

### Stage/Step Pages.

Some stage parameters can be edited globally, covering all stages. Active stages can be edited individually. Multiple steps can also be edited collectively by holding more than one pad simultaneously.

 Global - Press [Step]

Step/Accl Global			
Rept	Durat	. . .	
...	...	...	...
Offst	AcmM	-	-
...	Step		

Tap (Knob) for the selected parameter to edit in order to switch between the upper or lower options in a dual parameter row display.

 Individual Step\* - Hold step [Pad] +  [Page] to cycle through pages.

\* Multipress is also possible for multiple step edits along with the step range selection method.

Stg1 T.Durat:1 1/3			
Vel	Note	Gate	Durat
87	F2	50%	1
Offst	CvGld	JRng	Trig
0%	0	0st	100%

Stg1 Submenu 2/3			
Rept	Durat	. . .	
No	x 1	±0%	±0%
-	-	-	Rpt%
-	-	-	100%

Stg1 Accum 3/3			
Amt	Mode	Acm+	Acm-
+0st	Wrap	+7st	-0st
Total	Trig	%Mde	Acm%
+0st	All	Iqnor	100%

**Stage Options.**

The repeat and accumulator functions have been explained elsewhere in the manual. Here we focus on the Saga specific, individual stage settings. These are on page 1, displayed while holding an individual stage pad.



Hold a [Pad] for an active or inactive stage within the track.

Stg1	T.Durat:1			1/3
Vel	Note	Gate	Durat	
87	F2	50%	1	
Ofst	CvGld	JRng	Trig	
0%	0	0st	100%	

The currently selected stage plus the total track duration is displayed in the page header.

Saga Stage Parameters				Page 1/3
<b>Vel</b> Velocity	<b>Note</b> Note Applied	<b>Gate</b> Gate length	<b>Dur</b> Stage Duration	
Sets the velocity of the individual stage. Affects the amplitude level.	Sets the note value for the stage. Displays the note count if a chord is applied to the stage.	Sets the note gate length. Represents the note length on the step.	Duration of the note. This determines how long the note/chord plays in step count.	
<b>Ofst</b> Offset	<b>CvGld</b> CV Glide	<b>Rng</b> Note Range	<b>Trig</b> Trigger probability	
Offsets the note timing to delay the step in the sequence.	Sets glide amount between notes to introduce a smooth note transition. CV only as MIDI doesn't support.	Sends a random note with pitch variation. The note generated is within the active, +/-24 to 0 to +24 scale interval range *.	Percentage chance of whether the note will played or will not play.	

\* While the range is generally stated as 'st', semitones, the actual interval is based on the relationship between notes in the currently active scale. The +/-24 therefore is a note interval between notes in the scale and not strictly semitones

**Stage Behavior.**

Once a track length is set, indicated by red pads, the notes or chords can be applied using the keyboard pads and also by manually adjusting each stage parameter set. Some useful information on the behavior of the Saga sequencer will highlight the key creative attributes. Duration and offset affect the note timing.

Total Track Duration  
= Track Length + Step Dur, extra steps  
Shown in step page header.  
Example 32 + 3 = 35

Each stage note/chord will play for the applied 'Dur' duration. This is applied in step count.  
Playhead will pause for the step duration, then when complete will continue at the next stage. Example is Dur = 4, +3 extra steps.

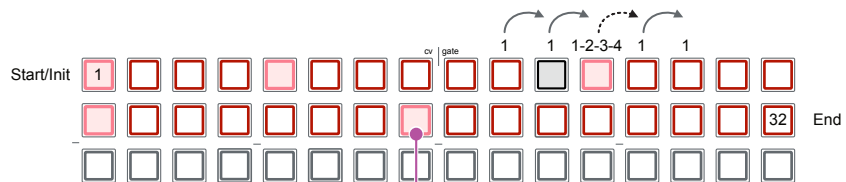

The 'Ofst' Parameter will apply a % offset to the note timing, pushing the note back in time.



Playhead follow the step including the offset delay.

In addition to the base sequencer parameters, Saga also has an accumulator and repeat function which can add more variation and interest to the creation of patterns and arrangements.

## 6 Modes

### 6.12 MIDI Player Sequencer Mode

MIDI Player is a sequencer mode that enables MIDI files in the .MID format to be imported and played within ONE. Files must be located on the installed SD Card and can be imported from the sequencer. Import is handled in the project menu.

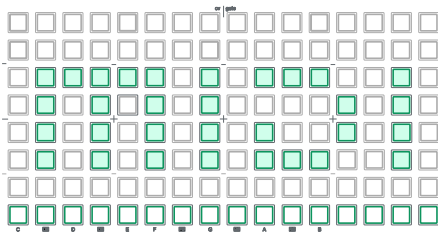

The % process when playing the MIDI file will be displayed on the main screen. No editable parameters exist.

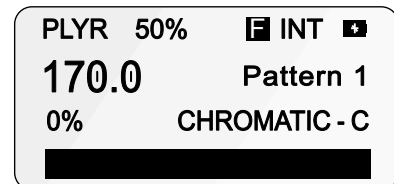

#### Creating a Sequence

**Trigger Section length.**  
[Init] or [End]



The [Init] and [End] buttons will display the start/end locators of both the note and trigger sections. Tap the purple pads to set the start and end on either section while holding the buttons.

**Add / Remove a Trigger.**  
Tap a trigger pad.



Tap a, dark purple trigger section [Pad] to activate or deactivate a trigger step. Active stages are brightly lit in the sequence color.

**Add Note or Chord.**  
Hold [Pad] + Press Note.



Hold an unlit, empty [Pad] in the note section + tap the keyboard note or play a chord. Ensure the sequencer voice setting, found on page 3, is set to 'Poly' in order to apply chords.

#### Sequencer Setup Options



The sequencer setup is accessed by holding [Shift] + [1] - [8].

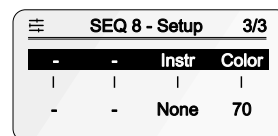
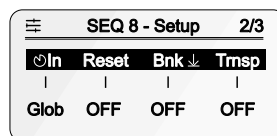
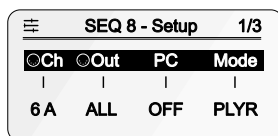

## Loading MIDI Files.

Once a file has been loaded, the transport and playback functions operate as normal. The MIDI file should be stored on the SD Card: Root / midifiles folder. Then the card inserted into ONE.

**Open Project Menu**  
Hold [Shift] + [Perf].



+



Open the project menu. Scroll using the first or last knob to navigate through the menu.

Choose the 'Load MIDI File' option, then press (Knob) to select.

## MIDI Player Considerations

Be aware that a number of MIDI player constraints should be considered. Due to the nature of the MIDI being developed outside of the ONE MkII environment the following points should be taken into account.

### Functional Constraints & Comments

- MIDI Note On/Off data is imported. Other MIDI data such as CC, Sysex and Pitchbend will be ignored.
- MIDI pattern should be a maximum length of 8 bars, single track and a maximum polyphony of 7 notes. There are ~1280 events available per pattern, quantized at 24 PPQ.
- Scale is forced to chromatic / root C when selecting the mode which also means that 'Harmon' is not available.
- The [Init] and [End] are not available for setting the per sequencer loop and sequencer pages.
- The [X2] & [/2] options have no effect as the playback is tick based.
- The [Expand] and [Condense] functions are not available. No grid to scale.
- The Gen, Random Generator, Track, Step fill/groove and Step Rec all remain silent.
- The 8 sequencer Mod lanes are available.

# 6 Modes

MO PO DM SA

## 6.13 Accumulator

The accumulator function is available in sequencer modes, mono, poly, domino and saga. The accumulator is a tool that triggers a defined step while progressively evolving this steps pitch on each sequencer cycle. This function 'accumulates' controlled note value changes each time the accumulator step triggers. Pitch intervals, typically semitones, will therefore be added or subtracted from the previous trigger value for the same step to develop and evolve its note over time. Intervals are based on the scale The option to set a probability or logical condition or fill command as to whether the accumulator is applied at each step iteration is also possible.

### Accessing the Global Accumulator Step Limits

The accumulator limits can be applied at a step level, where individual steps can assigned accumulator settings including the upper and lower limits, or at a global level where accumulation limits are set for all steps collectively in the sequence and all other accumulator settings are then applied per step.

Step chord Global - Press [Step]

III	Step/Acml	Global
Rept	Durat	... I
...	...	...
Offst	AcM	Acml+ Acml-
...	Trck	+7st -0st

#### AcM.

Step: Set to step, will allow each step to edit the accumulator settings for each individual step.

Trck: Set to track to set the limits globally for the sequence and other accumulator settings per step.

The Acml+ and Acml- options appear here in AcM 'Trck' mode.

### Accessing the Individual Step Accumulator Settings

[Pad] + [Page expand]

Hold [Pad] + tap [Page] to cycle through to page 3.

Stp 2	Accum		3/3
Amt	Mode	Acml+	Acml-
+0st	Wrap	+7st	-0st
Total	Trig	%Mde	AcM%
+0st	All	Iqnor	100%



Tap (Knob) of the respective parameter to toggle between selecting the upper or lower parameter for editing.

### Accumulator Settings & Options

The parameter settings are used to configure the accumulator behavior and how the engine will operate when the step row is triggered at each cycle of the sequencer. Each time the playhead triggers the step the next iteration of parameter change will be applied within the criteria and boundaries set. These settings apply only to accumulation behavior of a step and not the discrete step triggers. While the range is generally stated as 'st', semitones, the actual interval is based on the relationship between notes in the currently active scale. The intervals are therefore based on the scale not strict chromatic semitones If accumulation applied to step column with multiple notes in Poly Mode, the entire column of notes is affected.

Step Submenu - Extended Parameters		Hold a step [Pad] + tap [Shift] or tap [Step] button to latch the global view.	
<b>Amt</b> Pitch change intervals	<b>Mode</b> Order of accumulation	<b>Acml+</b> Accumulation upper + limit	<b>Acml-</b> Accumulation lower - limit
Defines the pitch interval and +/- direction that the note will change on each trigger.	Sets the direction of travel for the accumulation of notes.	Maximum, upper +ve count limit before the accumulator resets and restarts.	Minimum, lower -ve count limit before the accumulator resets and restarts.
<b>Total</b> Count status - indicator only	<b>Trig</b> What is affected	<b>%Mde</b> Mode when condition is false	<b>AcM%</b> Probability & accumulation logic
Displays the current position / status in the accumulation count process. Display only.	Accumulation can be applied to only the step, only repeats for the step, or all steps & repeats.	Set to ignore or skip. These set the accumulator behavior when the logic condition is false.	Sets the probability or logic condition that determines if and when accumulator is applied.

**Mode: Options**

These diagrams show examples of how a single note value behaves on each sequencer cycle, i.e. each trigger of the note. An alternative for wrap, clip and pendulum exists which follows a similar pattern cycle but adds a level of randomization.

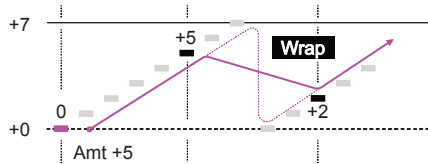

**Wrap.** Notes will accumulate in intervals set by Amt, adding or subtracting to its prior value before reaching Acml+ or Acml-. Continues the count Amt interval while wrapping around the limits.

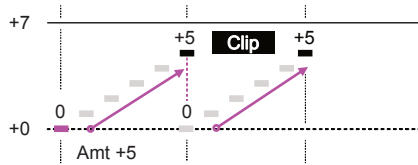

**Clip.** Notes will accumulate in intervals set by Amt, adding or subtracting to its prior value. Continues until reaching Acml+ then will reset and restart at Acml- or vice versa when the Amt is subtractive '-'.

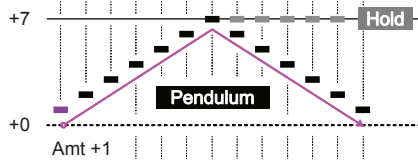

**Pendulum.** Will follow the natural cycle adding or subtracting notes in Amt intervals and will change direction when an upper or lower limit is reached.

**Hold.** Notes will accumulate in intervals set by Amt, adding or subtracting to its prior value. Once the Acml+ or Acml- limit is reached, the note will hold at the current pitch and continue through the sequence at this level. Intervals are based on the current scale.

## 6 Modes

### Deconstructing the Accumulator

The examples show the behavior of a single step note when assigned with the accumulator. This refers to the Trig parameter being set to apply to 'All' - both notes and repeats (either or both can be set). Only the accumulator step will automatically change its value each time the step is triggered or a step repeat is triggered. The output from this algorithm will add or subtract intervals i.e. semitones, set by the amount, the next time the step is triggered or repeated. The original note value is the reference from which the pitch values will evolve. The function is explained with examples below.

#### Example

Scale: Dorian Root C2      ■ Accumulator applied to step.    ■ Original note.

**Trig All**      'All' applies accumulation to both steps and repeats. If repeats exist on the accumulation step they will also be used in the pitch accumulation count and also to the pitch adjustments applied to the repeats.

**Mode Wrap**      Notes increment each cycle and at the max limit will wrap and continue at the intervals set by amount. In this example it will wrap from Acml+ through the Acml-

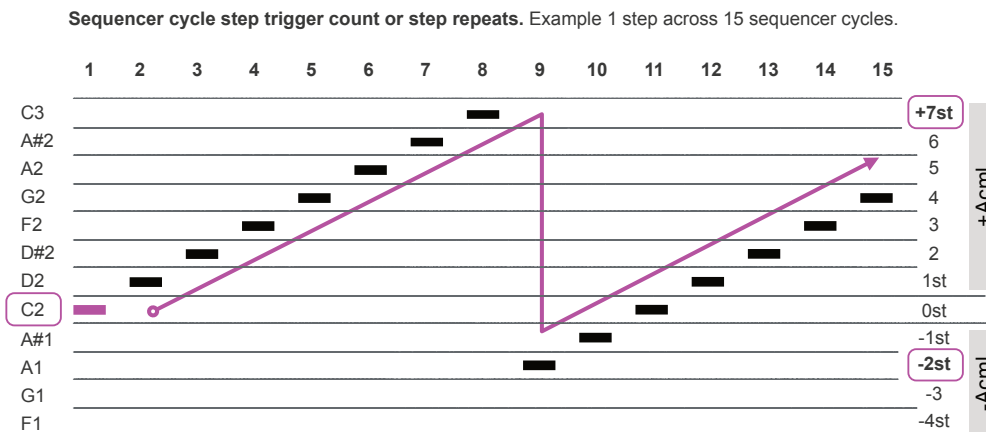

**Amount +1st**      Increment up 1 interval (scale dependant, e.g. 1 semitone in chromatic scales) per sequence cycle. Range is -24st to +24st with the polarity defining if the notes are added to or subtracted from the previous note. If the value was +3st the increment order would be 0, +3, +6, -1, +2, +5, -2, +1 etc.

**Acml+ +7st**      Maximum interval limit before wrapping or changing direction if pendulum mode is applied. Range is 0 to +24st.

**Acml- -2st**      Lower limit interval position. Range is 0 to -24st.

**% Mode**      %Mode sets the behavior of the accumulation when the accumulator probability logic condition is not met. It evaluates the logic condition and establishes whether to skip the accumulation update but retain and replay the last accumulated note for the sequence cycle or just ignore any accumulated value until the next update cycle.

Ignore, will ignore the accumulation when the probability condition is not met. There is no accumulation applied and the step will play its original value.

Skip uses the last accumulated value but doesn't accumulate further if the probability condition is not met.

## 6.14 Channel Multiplex

Channel Multiplexing, named by the parameter option as ChMx, will redistribute active voices, typically created from a chord, to other incremental MIDI channels, upwards from the base. The current sequencer channel is the 'base' starting point. When set to an option other than off, it is applied to all chords in the sequence.

Channel multiplex is a feature found in the polyphonic based modes, Poly, Chord, Domino and Saga.

With channel multiplexing on, the following behavior applies:-

**2 Lo to 8 Lo.** Lo represents the lowest note in a chord. The lowest note always remains on the base MIDI channel. Each of the chord's other notes will be directed individually, in increasing pitch order, to the consecutive higher MIDI channels. Notes are distributed across channels based on the selected Lo span number. At the end of the Lo range, the next note will wrap back to the base, and the cycle continues.

**2 Hi to 8 Hi.** Hi represents the Highest note in a chord. The highest note always remains on the base MIDI channel. Each of the chord's other notes will be directed individually, in decreasing pitch order, to the consecutive higher MIDI channels. Notes are spread over channels based on the Hi span number selected. At the end of the Hi range, the next note wraps back to the base, and the cycle continues.

Example: 2 notes (C4, G4), Base sequencer channel = Ch 1 and span = 2:

2 Lo: C4 is sent to Base MIDI Channel 1, G4 is sent to MIDI Channel 2.  
If the chord had a third higher note, should it exist, it will wrap back to the base channel

2 Hi: G4 is sent to Base MIDI Channel 1, C4 is sent to MIDI Channel 2.  
If the chord had a third lower note, should it exist, it will wrap back to the base channel

# 6 Modes

NOTES

## 6.15 Harmonizer

**MO PO MT CH SC MC DM PY SA**

Harmonizer is an extremely powerful and musically creative tool. In simple terms, the harmonizer links sequencers musically by aligning the note pitch across patterns. A selected chord or poly mode sequencer takes the role of primary leader, which manages the note pitch based on its scale, root, and associated patterns. Other mono, poly, multi, matriceal, stochastic, domino or saga sequencers can be set to follow the leader. So the note patterns and rhythmic trends are set by the follower, but the note pitch values are controlled in harmony with the primary lead. The melody brings all of the connected sequencer patterns together harmonically.

Example: Harmonizer core principles

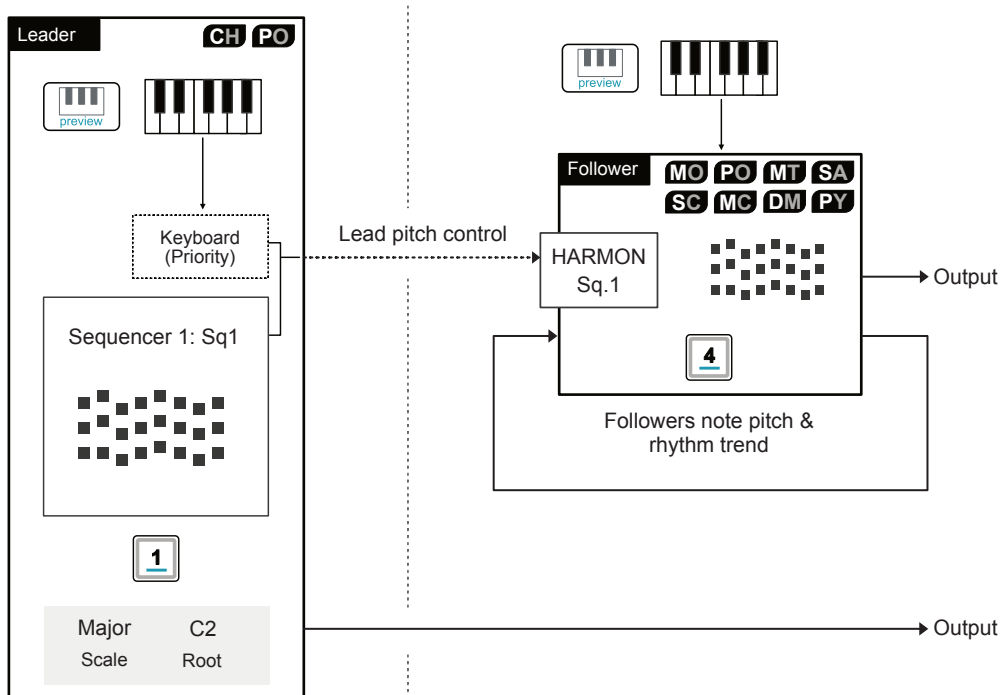

### Primary Leader

Typically chord mode or optionally poly mode sequencers

Any sequencer will be recognised and available as a primary leader by the follower sequencer as long as it is set to chord or poly mode.

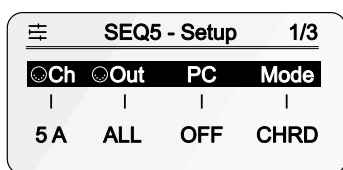

### Secondary Follower

Mono, poly, multitrack, matriceal, stochastic, domino, saga, or MIDI Player mode sequencer.

To connect the follower sequencers, set the scale to 'HARMON' and the root to the sequencer number Sq.x which will act as the primary leader. The octave can still be edited as usual in the follower.

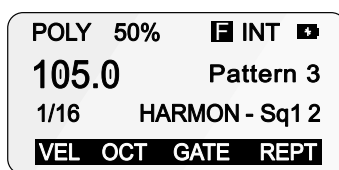

The harmonizer is based on each sequencer configuration and is not a standalone tool with dedicated pages and parameters. All settings are found in the existing sequencer main pages. The transport must be playing to affect the harmonization of the followers from the leader sequencers.

**Sequencer - Primary Leader**



**Sequencer Settings**

Hold [Shift] + tap [1] - [8]. The settings menu will open which consists of multiple pages. Select page 1/3.

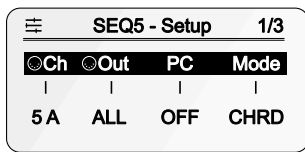

**Sequencer Mode**

In Page 1, turn (Knob 4). Scroll to navigate through the mode options. Press (Knob 4) when highlighting the mode type to confirm assignment to the sequencer.



For the Harmonizer primary lead, set to either, Chord or Poly Mode.

**Sequencer - Secondary Follower**



**Sequencer Settings**

Tap [1] - [8] to select a sequencer to act as the follower. This must be set to mono, poly, multitrack or stochastic using the method explained above.

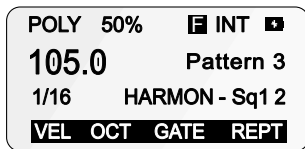

**Scale & Root**

The scale option will select an harmonizer configuration when setting it to 'HARMON'. The root will link to the primary sequencer labeled as Sq1, Sq2 etc



Set the scale to harmonizer. Hold [Shift] + turn (Scale), knob 3 counter clockwise until 'HARMON' is selected.



Set the root to the chord or poly sequencer primary leader. Hold [Shift] + turn (Root), knob 4 to select sequencer by number, Sq1, Sq3 etc.



The octave can still be changed as normal in the main sequencer page. Turn (Oct), knob 2.

Any changes to the lead sequencer will affect the follower when the harmonizer configuration is set. This includes pitch orientated changes such as scale, root, transposition, modulation, randomization etc.

## Keyboard Control

Either the leader or follower sequencer can be controlled by the sequencer or grid pad keyboards. An external MIDI keyboard can also be used.

### Leader Sequencer & Keyboard.

Chord and poly mode have built in keyboards which allows the playback and performance to be controlled. The keyboard takes precedence over a running sequencer. However it also may be possible to disable the leader sequencer if just using the keyboard to ensure the last notes played are retained. Muting a sequencer will also disable it from the harmonizer of the follower while the sequencers are running.

### Follower Sequencer & Keyboard

The follower sequencer keyboard view will layout the grid piano style. When the harmonizer is in action, the keyboard will display the harmonized notes on the grid with green lit columns in real-time. The keyboard can be played to compliment the harmonized patterns on the follower sequencer.



Select keyboard view for the leader or follower.  
Preview can be set to operate as normal.

Follower Keyboard

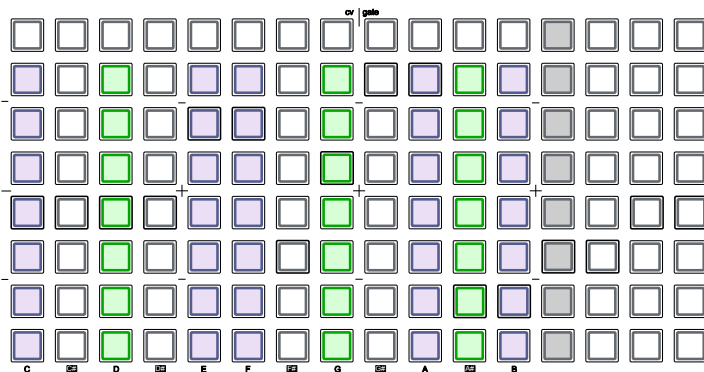

Green pads signify, in real-time while playing, the application of the harmonizer pitch affects for the notes.

## Harmonizer Octave Range

The octave can still be set in the main screen when the harmonizer is set. However there are some considerations that should be noted when using the harmonizer reflected in the note range.

- Steps set in the lower octaves of the follower may not be affected by an harmonised note. This is due to the octave range limitations. Harmonizer references chord degrees from root C2. So, for example, if a C2 and C3 are notes in the follower, then lower notes will generate an output based on the chord in the leader sequence which may result in higher note outputs.
- There are two settings in the config > performance options that support the Harmonizer octave / note management. These affect how the octave range is applied to the follower :-
  - Harmonized seq octave max. Sets the maximum octave step that the follower sequencer can make when controlled by the lead Harmonizer sequencer. Default is 1, options 0, 1, 2.
  - Harmonized seq stays in base octave. If set to Yes the leader octave offsets are ignored by the follower and keeps the octaves within the base range, harmonically close to the root.

NOTES



# Modulation

Modulation is the manipulation of parameters in order to add interest and movement in sound design, music production or to experiment with audio. In simple terms modulation is the control of one parameter from the changes made by another. An example is to use a hand to manually move the volume knob of an amplifier up and down or to use a device such as an oscillator to manipulate volume to create a tremolo-style effect. In OXI ONE MkII, there is a powerful array of modulation options that can be used to affect external devices and DAWs to increase creativity. Modulation in OXI ONE MkII would typically drive the MIDI output messages, for example, with CC or control change values, pitch bend, or aftertouch. It can also be used for CV or control voltage variations. Modulation can also be applied to internal parameters configured with the mod matrix. The destination parameters can then be controlled or modulated from OXI ONE MkII's patterns or from the four rotary encoders for MIDI output. Each sequencer has eight independent modulation lanes, which can be used to set up and program parameter variations over time. The same way that pitch-based patterns affect notes. The modulation lanes allow the automation of parameters, meaning that the destination parameter values can be automatically changed and shaped over time in sync with the sequencer and its steps. Modulation unlocks a lot of creative options and adds more dynamics and movement to tracks and songs.

# 7 Modulation

## 7.1 Modulation Overview

Each sequencer has 8 independent modulation lanes, each of which is configurable and has up to 2 MIDI and 2 Internal destinations available to control. A lane has up to 128 steps accessed using the step page 16, 32, 48, 64, buttons and its step length controlled by Init and End buttons. Multitrack mode has 1 mod lane per track.

### Modulation Lane Source

A modulation lane will map the trend of parameter change over time using the sequencer lane steps. This then will control destination parameters.

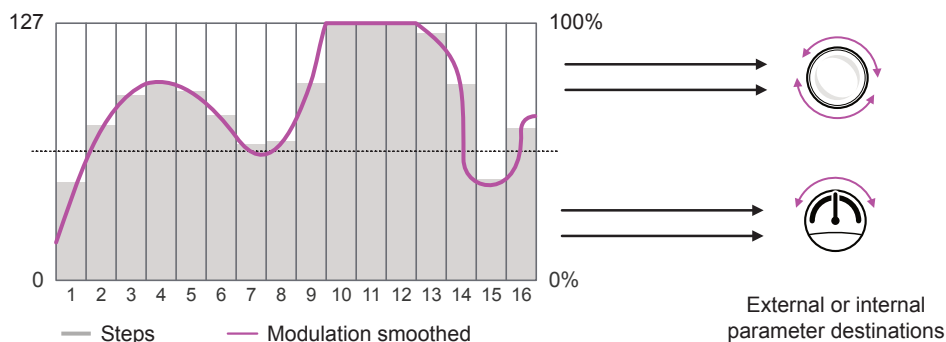

In addition to the modulation lanes, ONE also has two LFO's per sequencer. An LFO or Low Frequency Oscillator is a function that can cycle the value of a destination parameter based on its wave shape and speed. For example a parameter value can be changed in a triangular shape cycle. An LFO runs at a speed typically below the range of an audio oscillator and is used to modulate rather than generate sound.

### LFO Source

An LFO will generate a wave shape cycle at a defined speed in order to control and modulate a destination parameter value.

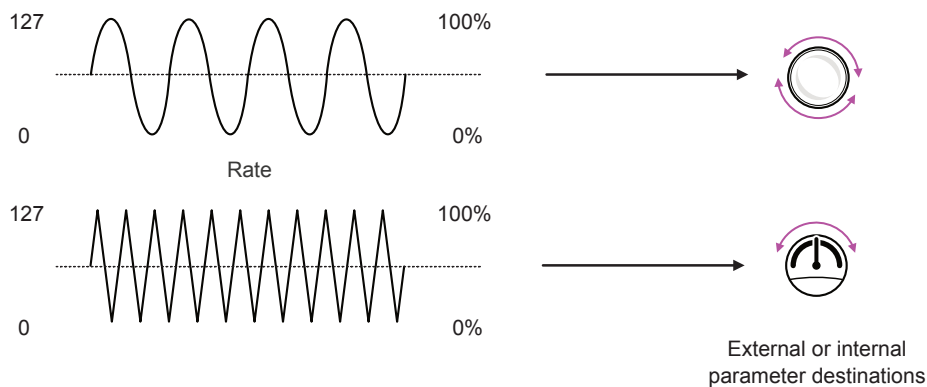

## 7.2 Modulation Lane Controls

Each independent modulation lane can operate with up to 128 steps. Up to 2 external and 2 internal destinations can be assigned to each lane. A modulation lane will output MIDI messages such as CC, Pitch Bend, Aftertouch and even PC messages as well as parameters such as velocity, pitch and even randomization to internal parameters.

Modulation can be applied with a linear 0-100% range or bi-polar -100% to 100%

### Modulation Lanes



Tap [Mod] to open the main modulation page to setup or edit the lanes. This represents and displays the status of all 8 lanes

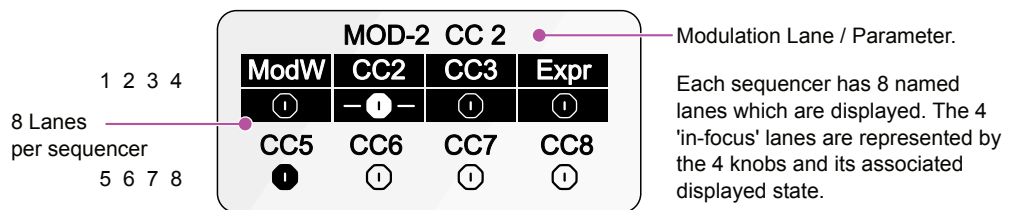

'In-focus' is a term used here to refer to a lane that is under the control of one of the 4 knobs.

As above, general manual illustrations are inverted for clarity. The following examples are shown as truly displayed.

**Lanes muted**

Quickly tap a knob to select its mod lane. Tap again to change focus between the upper or lower row. *In-focus lanes, i.e. editable with the knobs, are backlit white.*

Tag wings indicate the lane which is selected for editing and which is visible and presented on the modulation grid pad.

**Lanes muted**

Long press / hold a knob to mute or unmute a modulation lane. *Lanes are automatically unmuted / activated when turning a knob.*

Alternatively, hold [Mute] + Tap (Knob) to mute or unmute a lane.

**Lanes unmuted**

Modulation lane is displayed as unmuted / active. Default mode. *Example. Lane is unmuted/active, in focus - backlit white, and - - is selected for editing.*

Modulation lane is displayed as unmuted / active. Default mode. *Example. Lane unmuted/active, is not in focus - backlit black, and is not selected for editing.*

Mod lane data is retained when toggling a mod lane mute/active or unmute/inactive.

# 7 Modulation

## Global Parameter Edits - Page 1

Turning one of the 4 knobs in Mod view, page 1, will change the global value of the in-focus, primary parameter for the respective knob. This means all step values are edited relative to their current value by the single knob adjustment.



A flashing [Page] button signifies multiple pages are available. Tap [Page] to cycle through pages.

### Page 1 - All Modulation Lanes

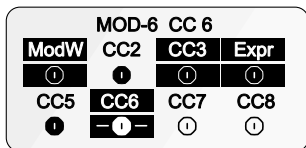

**Global Value.** Turn knob 1-4 representing the 4 highlighted, in-focus modulation lanes. The value will change for all steps in the lane and the global value range will be displayed while being changed. Positive values, bottom up in the mode color and negative in red, top down.

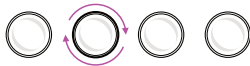

**Global offset.** Hold [Shift] + Turn knob 1-4 to edit the global offset value across all steps in the lane. Value range will be displayed while being changed. Reset using [Shift] + Hold (Knob). Grid pad colors indicate offsets with white for positive or pink for negative values.

## Creating Modulation Lanes

The grid represents the modulation source value for each step in the modulation lane sequence. Swipe to draw or tap to set the modulation values and create the shape. Maximum and minimum values can be set in the modulation lane settings. The length of steps is independent to the sequencer note steps but the process for managing length is the same. Use page [16], [32], [48], and [64] to change the step range page. Apply modulation using the grid in the [Mod] page.

### Typical Modulation Workflow

- 1

**Select a Sequencer**

Modulation lanes are available on all sequencers. Select and setup a sequencer where modulation will be applied.
- 2

**MOD Mode**

Setting up and editing modulation is performed in the [Mod] function.
- 3

**Choose a lane to edit**

All 8 lanes per sequencer are displayed in Page 1. Unmute / Activate a lane to edit with the 4 knobs. The pad grid will represent the selected modulation lane.
- 4

**Set the lane length**

Length and division are independent so can be set differently to the main sequencer length and division. Creates some interesting interactions and enables an evolving / generative feel to arrangements.
- 5

**Set the lanes parameters**

In Page 2 of the MOD function, the lane parameters can be edited. This includes the destinations, time division ranges and offsets.
- 6

**Create modulation shape**

The pads can be used to 'draw' a modulation profile shape across the range of modulation steps. The columns represent steps in the profile while rows represent the +/- value of the modulation for the step.

## Basic Command Summary

### Edit the Modulation

*Positive steps*



Tap a [Pad] to assign a positive modulation value to the step in the mode color. This is represented as bottom to top in the column, based on settings Min to the Max range.

### Edit the Modulation

*Negative steps*



+



Hold [Shift] + Tap a [Pad] to assign a negative modulation value to the step set in red. This is represented as top to bottom in the column. The Min value must be less than 0. Pitch Bend and CV pitchbend destinations automatically set the Min value to -127.

### Random Mod

*Generate Mod lanes*



+



Hold [Shift] + Tap [Randomizer] to generate a random modulation pattern.

### Clear Mod Step

*Reset to 0 Value*



Double tap the bottom [Pad] to clear the selected column modulation values.

### Clear Mod Lane

*Current Lane*



+



Hold [Shift] + Tap [Clear] while in the [Mod] page to clear the current modulation lane. This will clear only the current modulation lane. Note data is unaffected.

## Modulation grid layout

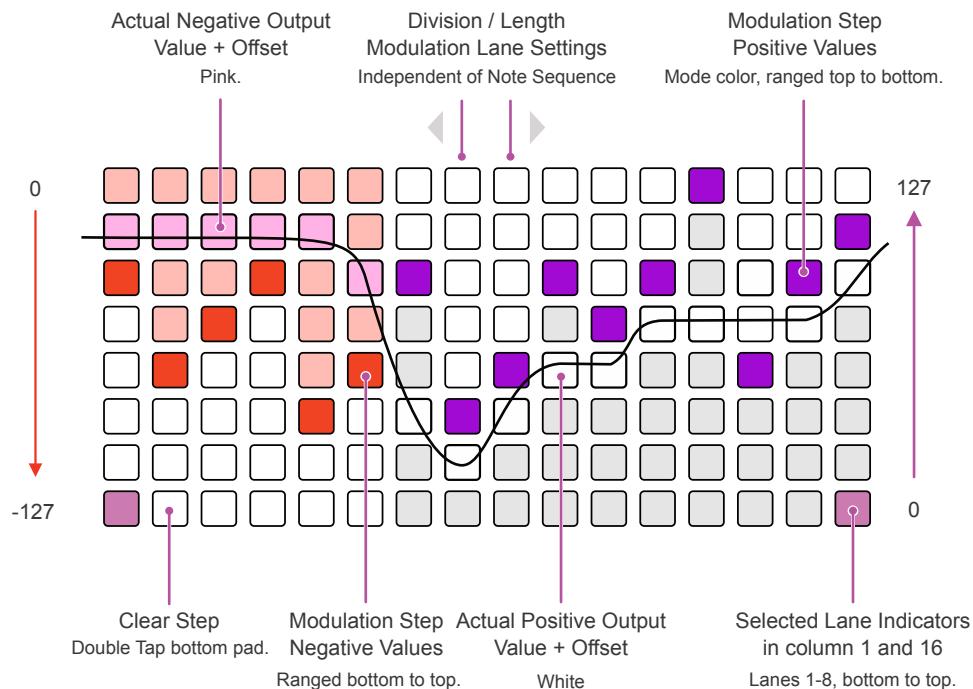

The actual modulation output is based on the step value plus the offset, indicated by the white / pink offset pad. A modulation curve or shape can be 'drawn' across the pads steps. The row represents the value for each step, based on its polarization dimension. These can be positive or negative. The column position represents each of the steps in the modulation pattern.

The first and last column's purple pads are a visual representation of the selected lane, 1 bottom to 8 top for the sequencer.

# 7 Modulation

## Lane Settings - Page 2

In the [Mod] page 1, select a lane by quickly tapping the associated knob. It will display wing tags on the lane state displayed when selected for editing. Press [Page] to select page 2 for the lane settings. These settings configure the lane behaviour and enables assignment of the four modulation destinations. The priority is MIDI / CC 1 then followed by MIDI / CC 2, Internal 1, Internal 2 then Off.

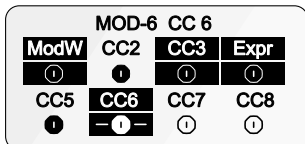

When viewing Page 2 settings list, the 4 knobs will still represent the mod lanes currently in-focus for editing on page 1. For example, in this illustration, knob 1, 2, 3, 4 will represent lanes 1, 3, 4, 6. Lane 6 selected.  
Black/white inverted from actual display for illustration clarity.



**Select Lane Parameters.** In the Mod function, Tap [Page] to open the modulation lane settings edit the lane setting for the currently selected lane.



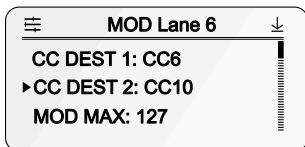

Alternatively, Hold [Shift] + Tap a knob in the mod lane page to edit the lane settings for the selected knob.



Lane In-Focus described in header

Lane Settings Page 2

### In the lane settings page:-

- Navigate  Turn knob 1-4. Each knob represents 1 of the 4 highlighted modulation lanes in [Mod] page 1. The display header will indicated the lane in focus. The options will scroll and the chosen parameter will be tagged ▶.
- Edit  Tap knob 1-4 to select the tagged parameter and open the sub-menu options. Turn to browse and tag ▶ the desired option. Tap knob to select. Use [Back] if needed to backup the menu.
- Reset  Keep hold knob 1-4 to reset the tagged ▶ option to its default value.

### Instrument Definitions

Instrument definitions are a quick way to map the OXI ONE MkII to the parameters of an external device such as a synth or effect pedal. Using instrument definitions is also useful when working with modulation destinations to speed up and apply an accurate mapping to defined external gear.

## Lane Setting Menu

Modulation, per Lane Setting Options		
Name	Setting	Option
CC Dest 1	CC destination 1	Destination 1 options for the MIDI output messaging; CC (see table), Pitch Bend, Aftertouch, PC or Off.
CC Dest 2	CC destination 2	Destination 2 options for the MIDI output messaging; CC (see table), Pitch Bend, Aftertouch, PC or Off.
Mod Max	Modulation upper limit	Sets the maximum value for the modulation range. Default is 127. Range is 7 to 127.
Mod Min	Modulation lower limit	Sets the minimum value for the modulation range. Default is 0. Range is -127 to 120. Flips automatically to -127 for PB/CV pitch bend.
Mod Offset	MIDI value offset	Applies a constant offset added or subtracted to the overall output value within the max / min range. Range +/- 127. Reset to 0 with [Shift] + [Offset] encoder.
Mod Random	Randomisation	Amount of bi-polar randomization applied, per step, to the output. Range is +/-100%.
Int Dest 1	Internal destination 1	Destination 1 option for the internal modulation or set to off. See internal destination table.
Int Amt 1	Internal amount 1	Amount of modulation applied. Used to fine tune the range and value. Range is +/- 100%, default 100%
Int Off 1	Internal offset 1	Applies an offset added or subtracted to the overall value within the max / min range. Range +/-127.
Int Dest 2	Internal Destination 2	Destination 2 option for the internal modulation or set to off. See internal destination table.
Int Amt 2	Internal amount 2	Amount of modulation applied. Used to fine tune the range and value. Range is +/- 100%, default 100%
Int Off 2	Internal offset 2	Applies an offset added or subtracted to the overall value within the max / min range. Range +/-127.
Division	Time Division	Time division for the modulation lane advancement. Bar, 1/2, 1/4, 1/8, 1/8t, 1/16, 1/16t, 1/32, 1/32t, 1/64. The x2 & /2 options also work in mod lanes.
Smooth	Slew time	Smooths by using interpolation between steps. A value of '0' is off and is therefore a stepped transition. Also affects CV outputs when modulation lane is assigned.
Linked	Linked sequencers	Mod lanes are by default linked to a sequencer. Sequencer edits such as Init, end etc apply to the mod lane. Mod lane edits do not affect the sequencer track. The link can be disabled by selecting 'No'.
Init	Mod lane start step	Starting step of the independent modulation lane. Same parameter as set by the [Init] button.
End	Mod lane end step	Ending step of the modulation lane to determine length. Same parameter as set by the [End] button.
Rename *	Rename tool	Allows the modulation lane name to be changed, max 4 characters.
Copy	Copy settings	Copies the settings and values from this mod lane in order to later paste to another mod lane.
Paste	Paste settings	Pastes the settings and values from to this mod lane from those previously copied from another mod lane.
Clear	Clear settings	Clear values and settings for this mod lane.

\* Modulation lane names can be edited to a four character label. If an instrument definition is assigned the name set for the parameters with CC's will be used.

## 7.3 Modulation Steps

When holding an individual modulation lane step pad in the grid columns, the current value for the modulation lane step will be displayed. This can be adjusted with the respective knob while the pad is held, enabling more precise step editing. The column pad position will reflect the current value. While a pad is held, all modulation lane values for the same step column will also be displayed on the screen. Editing any other lane with the knobs will automatically change the grid view to represent the adjusted lane.

### Editing Modulation Values on the Grid



Hold a column pad in the modulation grid view. Each column represents a step and the vertical position the parameter value. The purple first / last pads on the grid indicate the selected modulation lane.

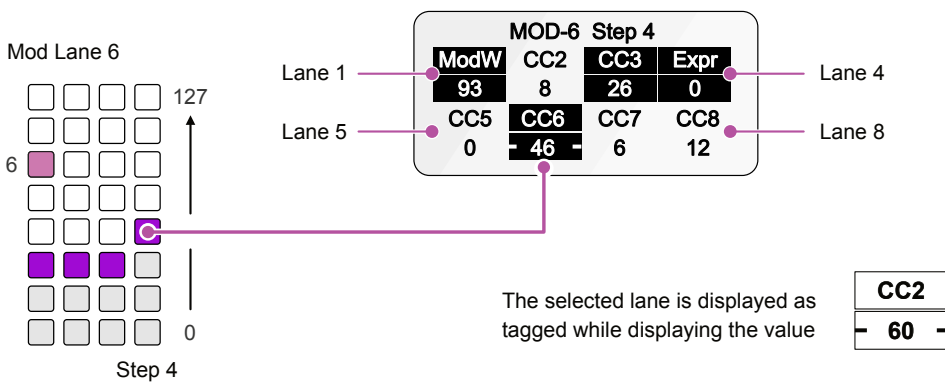

**Reset Value.**  
To reset the value to '0' double tap the bottom pad.

While holding the [Pad], Turn the respective knob to edit the lanes column value. Tap the knob to switch between the upper 1-4 lanes and lower 5-8 lanes.



**Edit Column Value**  
Hold [Pad] + turn respective (Knob)

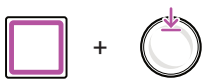

**Reset Column Value**  
Hold [Pad] + tap respective (Knob).  
Resets to the value but retains the global offset value

### Randomizing the Modulation Grid Values



In the [Mod] page, Hold [Shift] + Press [Randomize].  
A random value will be applied to each modulation step column.

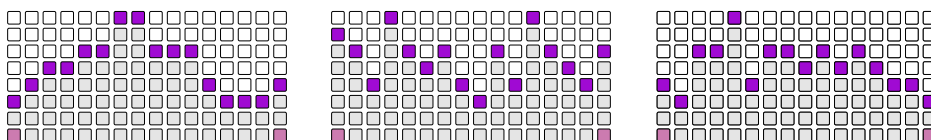

A new modulation profile is applied based on random values and within the Min/Max range in the settings for each combo press of shift + randomize.



## 7.4 Recording Modulation

It is possible to record automation values in real-time while the sequencer plays by using the modulation rotary knobs or by sending MIDI CC or Pitch Bend in from an external controller on the relevant channel. Recordings can be made for the sequence duration and as the sequencer loops the automation can be recorded continuously.

Guide to recording a modulation curve.

- Modulation Mode  Tap [Mod] to open the main modulation page and select a modulation lane to record into. For example Tap Knob 2.
- Play the sequencer  Tap [Play] to start the sequencer playing.
- Start recording  Tap [Rec] to start recording into the modulation lanes. This will continue and overwrite existing data while recording.

-  Turn a knob for the parameter lane to record. Any edits to any lanes will be recorded.

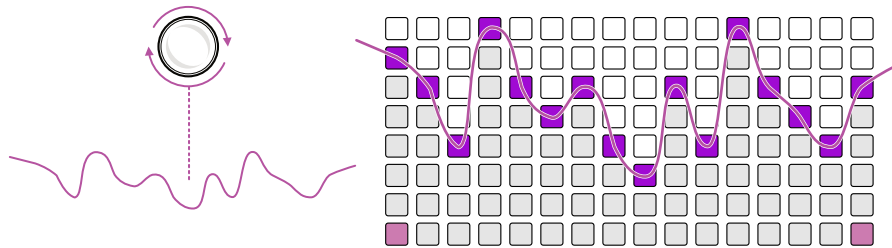

**Mod Recording Behavior:** The standard recording setting for a sequencer does not apply in full to the recordings made in MOD mode. Mod recording behavior is a combination of latch and touch. Recording will also continue for a fixed latch period after modulation ends for example stop tuning a knob. Values are overwritten while ever manual or latched recording is in progress. The latched recording time will end when the displayed 'Recording' message for the parameter is no longer visible.

Be aware that automation can be overwritten as the modulation sequence loops during recording. It is important to be aware of the recording length required while recording and avoid overwriting data already captured.

- Stop recording  Tap [Stop] to conclude modulation recording.

# 7 Modulation

## External MIDI Recording

External MIDI devices can also be used to record automation into ONE. Ensure the MIDI settings on ONE and the external device are set appropriately, including the MIDI channel. Follow the same steps to record as with internal modulation recording.

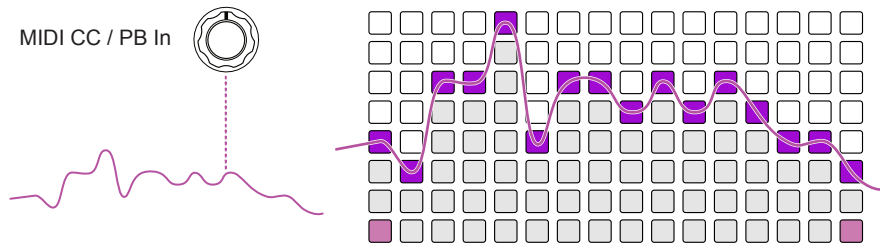

## External MIDI Latch

While strictly speaking, MIDI latch is not a recording tool, it does take priority over existing modulation. Any incoming MIDI CC (or PB, Aftertouch) message will temporarily override the currently active modulation values. The musical window is scaled using BPM and the lane division. This means that the incoming MIDI will control the destination and the existing modulation will automatically take back control when the MIDI CC/PB input message ceases.

The pre-requisites for External MIDI latch to operate are:

1. The incoming MIDI must be on the same channel as the modulation output.
2. The MIDI Thru parameter is set to ON for the specific MIDI input connection.
3. MOD Recording is not active.

## 7.5 Modulation Matrix

The modulation matrix allows routing of external MIDI and CV inputs to ONE's internal destinations in or to pass through to external gear. This can use the MIDI TRS, USB, Bluetooth ports or the CV connections and allows re-routing of devices in and out or to connect external devices in order to modulate ONE's parameters. Each sequencer has its own mod matrix.

### Project Map

Maps internal functions and external MIDI and defines the routing. The modulation mapped and applied in a project map will apply to all patterns in the project. Use the mapping slot for the current project, for example GLB1 for Project slot 1, in order to create or edit the mapping. Changing patterns in the defined project will still use the same project mapping but changing projects will not. Mapping is used for MIDI and Internal destinations.



### Pattern Map

Maps internal functions and external MIDI and defines the routing. The modulation mapped and applied in a pattern map will apply to only the selected pattern in the project. Use the mapping slot for the current pattern, for example PAT2 for Pattern slot 2, in order to create or edit the mapping. Changing patterns within the project will switch to the respective map for the new pattern. Mapping is used for MIDI and Internal destinations.

### CV Inputs

This is used to map incoming CV values to internal parameters or to external MIDI or CV.

Access the mappings in the 'Ext Mod' matrix.

**Mod Matrix**  +  Open the modulation matrix, Hold [Shift] + Press [Mod].  
Access to the project and pattern mappings and CV.



## Project &amp; Pattern MIDI Modulation Mapping - 1-16

Setting	Options	Description
Type	Off, CC, Note, LFO1, LFO2, Note - On Toggle, Random, Mod Lane	The type of input message for it to be recognised and processed in the mapping. Off means it is not used.
Number	CC or Note Number.	The CC value or the MIDI standard note number that must be recognised for the mapping.
MIDI In Chan	Same, All, 1-16	Same listens to the same MIDI channel as the sequencer (not the track). All, listens to all channels for inf CC or note matches otherwise set a specific channel number 1-16.
Learn	<i>Utility</i>	Sets ONE to listen to the incoming MIDI messages in order to auto map to the input message recognised.
Track	Matriceal & Multi Tracks only	Select the track affected by the incoming signal.
CC Out	CC Number	Sets the CC number or message that is externally forwarded to the same MIDI channel assigned to the sequencer or a multitrack's 1 <sup>st</sup> track or a matriceal track.
CC - Int Amt 1	-100 to +100%	Amount of modulation applied to the CC forwarded message or Internal destination 1 depending on which is active.
CC - Int Ofst 1	-100 to +100%	Applies an offset to the CC forwarded message or Internal destination 1 depending on which is active.
Int Dest 1	Internal destinations	Internal destination 1. Sets the target for the non-destructive modulation from the list of internal destinations.
Int Dest 2	Internal destinations	Internal destination 2. Sets the target for the non-destructive modulation from the list of internal destinations.
Int Amt 2	-100 to +100%	Amount of modulation applied to the Internal destination 2.
Int Ofst 2	-100 to +100%	Applies an offset to the Internal destination 2.
Para Dest 1	Global destinations	Internal global destination 1. Target for the destructive modulation from the list of global sequencer destinations.
Para Amt 1	-100 to +100%	Amount of modulation applied to the global destination 1.
Para Ofst 1	-100 to +100%	Applies an offset to the Internal global destination 1.
Para Dest 2	Global destinations	Internal global destination 2. Target for the destructive modulation from the list of global sequencer destinations.
Para Amt 2	-100 to +100%	Amount of modulation applied to the global destination 2.
Para Ofst 2	-100 to +100%	Applies an offset to the Internal global destination 2.
Consume	Yes / No	Yes will consume MIDI meaning it is not passed on to other MIDI mappings or outputs. Set to no to pass MIDI onwards.
Copy Map	<i>Utility</i> . Current or All	Copies the settings for the currently selected mapping or all mappings for the sequencer. Allows coping to another mapping in the project or pattern.
Paste Map	<i>Utility</i> . Current or All	Pastes the copied settings for the currently selected mapping or all mappings for the sequencer.
Clear Map	<i>Utility</i> .	Resets the currently selected mapping to the defaults.
Last Value	<i>Utility</i> .	Displays the last value that was received for the mapping. This must be a recognisable MIDI message. CC - actual value, Note On value 127 and Note Off value is 0.

# 7 Modulation

NOTES

## 7.6 CV Input Modulation

There are two CV inputs on the OXI ONE that are connected through the single 3.5mm CV input port. A standard TR patch cable will give access to CV In 1 while a stereo TRS input split to two TR Mono inputs will access both CV In 1 and 2. The hardware CV Input range of ONE is -3v to + 5v. This is covered in the connectivity section.

CV input can be used to modulate an internal parameter, either in the sequencer mode parameters or can be routed to modulate the MIDI CC output by configuring in the modulation matrix.

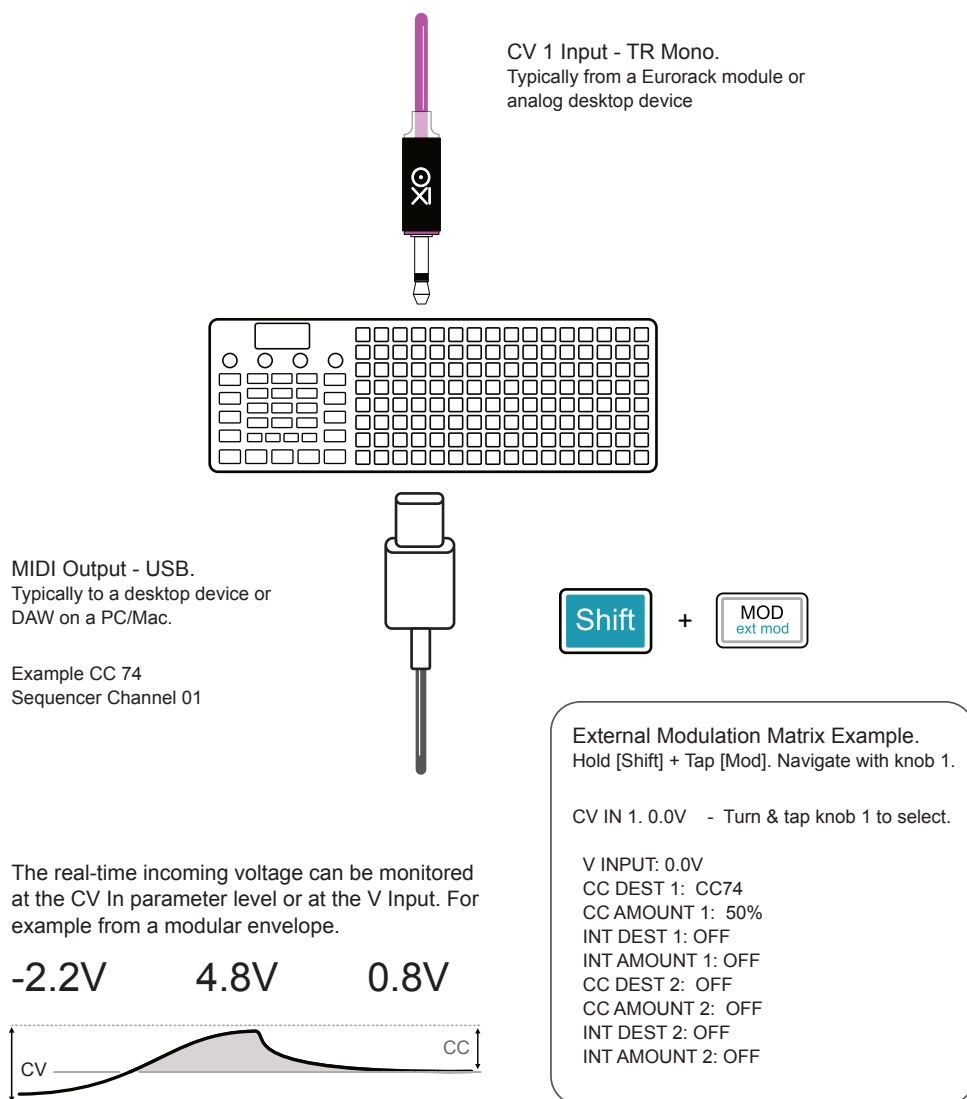

When using incoming CV as the modulation source, internal parameters can be assigned as the destination, but not the global sequencer parameter destinations. Also external CC can also be set as a modulation destination where the CV is effectively converted to MIDI CC. There are 2 internal and 2 MIDI destination options available. The MIDI channel is assigned per sequencer or track.

Only positive values are converted to MIDI so any negative CV values will be clipped at 0V. Pitch bend is the exception which will send bipolar MIDI output.

## 7.7 MIDI Modulation

MIDI CC can also be used as a modulation source. This is configurable in the modulation matrix where up to 16 incoming MIDI signals. MIDI inputs can be accessed from USB, TRS or Bluetooth.

MIDI input can be used to modulate an internal parameter, either in the sequencer mode parameters or can be routed to modulate MIDI CC output by using the modulation matrix. Unlike CV, MIDI can also control the global sequencer parameters.

Example: MIDI Matrix

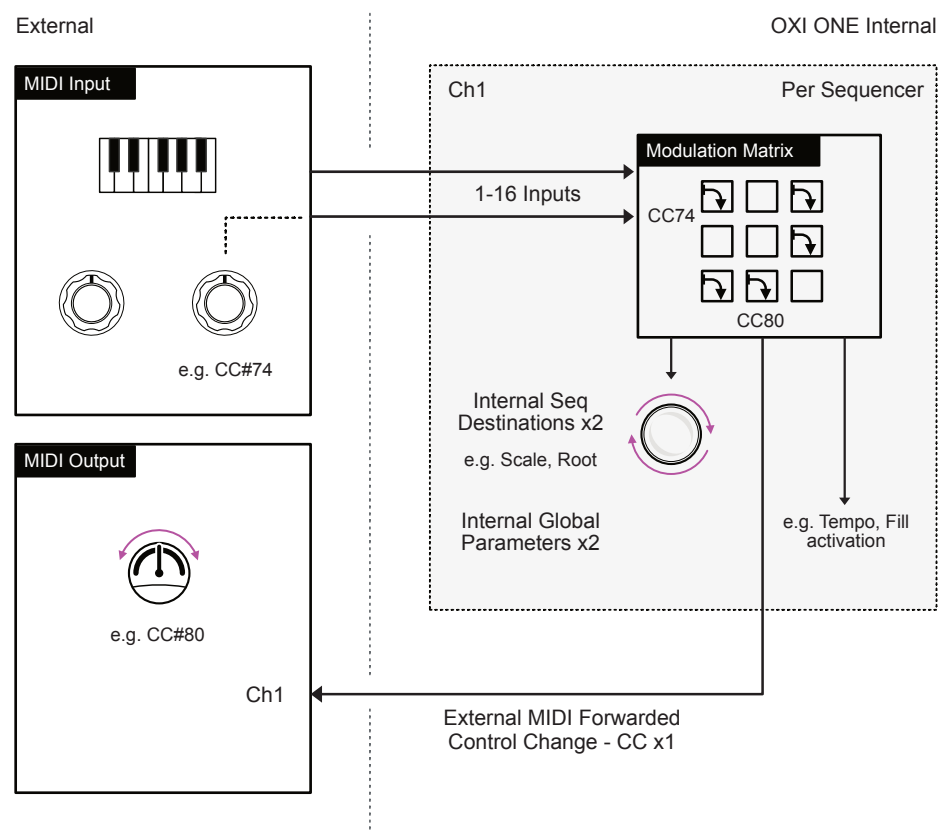

—Note—

The data over a MIDI ports can be merged across all ports A, B and C. This will ensure all messages are transmitted through each port on the equivalent channel. This is configured in the Config > MIDI > MIDI Port Merge setting.

# 7 Modulation

## 7.8 LFO Modulation

OXI ONE has 2 LFOs per sequencer each of which can be used as the modulation source. An LFO is a Low Frequency Oscillator, which generates a slow cycle waveform used to modulate or change a parameter value across the LFO wave shape at a defined speed. Each LFO can be configured in the LFO page to modulate one internal and one external MIDI parameter. CV can also be set as a destination in the CV Gate routing.



Press [LFO] to access the low frequency oscillator pages 1 and 2.  
Press [Page] to cycle through LFO 1 and 2 pages.

Page 1 - LFO 1

LFO 1/2			
Wave	Rate	Amt	InDst
Tri	1/2	OFF	OFF
Retrig	Phase	Offst	⊙Dst
OFF	0%	+0	OFF

Page 2 - LFO 2

LFO 2/2			
Wave	Rate	Amt	InDst
Sqr	1/4	OFF	OFF
Retrig	Phase	Offst	⊙Dst
OFF	0%	+0	ModW

Tap any knob to switch focus between the upper parameter and the lower parameter. Turn knob (1) - (4) to edit the values, Press knob to confirm.

Hold any knob to reset the value to default.

LFO Settings				Page 1 & 2
Wave	Rate	Amt	InDst	
Wave shape	Speed	Amount of modulation *	Internal Destination	
Selects the wave shape for the oscillator.	Speed of the LFO. Free running clockwise, counter clockwise is clocked to tempo.	Amount of modulation range applied to both external and internal destinations.	Sets the internal destination parameter for the LFO to modulate based on seq mode.	
Retrig	Phase	Offst	Dst	
Oscillator retrigger	Oscillation phase	Offset	MIDI Out Destination	
On - Retrigger the osc on each sequence note. Off - runs free, no retrig.	Sets the +/- phase position of the LFO cycles.	Sets an offset amount to the LFO value. Useful for unipolar applications. Not applied to CV.	Sets the external MIDI message destination for the LFO to modulate. CC, PC, Pitch bend etc.	

\* The amount of modulation is adjusted for both internal and external destinations when turning knob 3 (Amt). Hold Shift + Turn (Amt) Knob 3 to set the MIDI External amount individually.

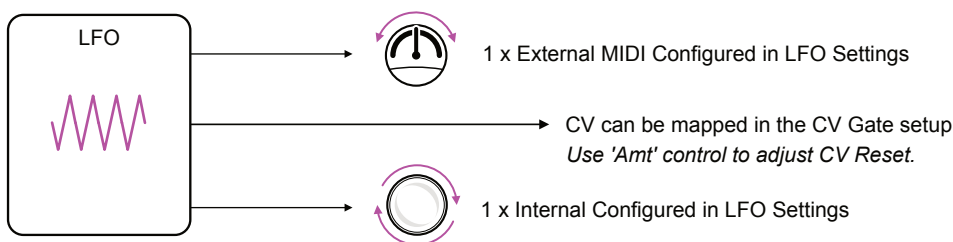

—Note—

The LFOs only operate while the sequencers are running. If the sequencers are stopped, the LFO will not run. Press play to experience the LFO output results.

## Wave Shapes

Tri - Triangle Wave

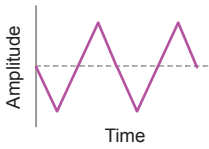

Squr - Square Wave

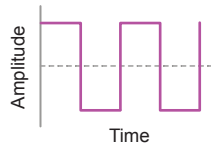

S\_H - Sample & Hold \*

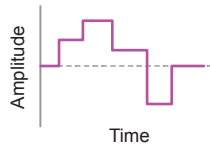

Ramp

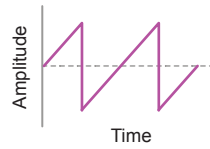

Fall

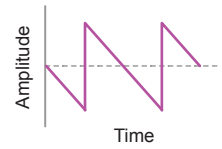

Sine

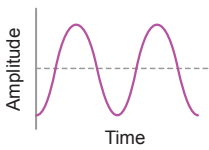

Line \*

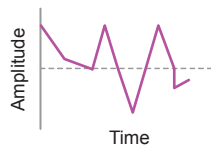

Gate - Gated Wave \*

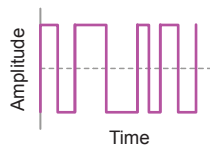

Nois - Noise \*

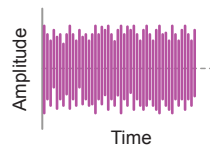

Wav1 - Wave 1

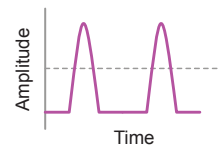

Wav2 - Wave 2

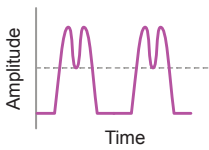

Wav3 - Wave 3

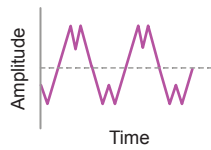

Wav4 - Wave 4

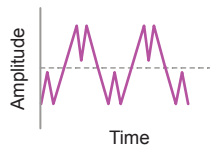

Wav5 - Wave 5

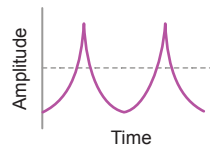

Wav6 - Wave 6

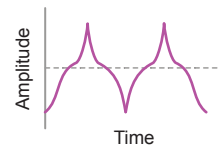

Wav7 - Wave 7

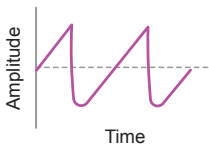

Wav8 - Wave 8

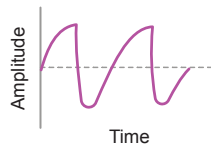

Wav9 - Wave 9

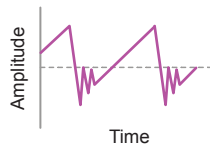

Wav10 - Wave 10

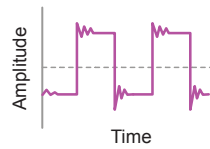

Wav11 - Wave 11

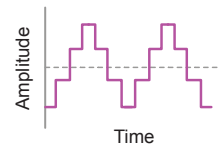

Wav12 - Wave 12

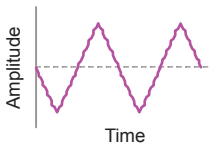

Wav13 - Wave 13

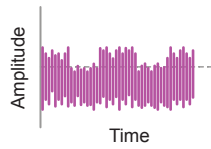

Wav14 - Wave 14



\* Randomly generated

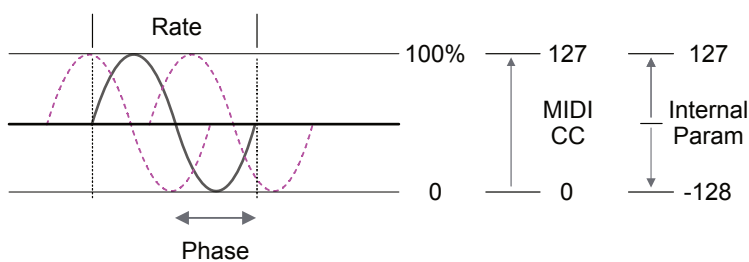

LFO range will depend on the destination. In general, CC MIDI will operate over a range of 0-127 to match the 0-100% setting. On the other hand, internal parameters will operate as bi-polar over -128 to 127. Offset for CC can be used to shift the range. Amount is not normalized across destinations.

# 7 Modulation

## 7.9 Modulation Destination Reference

### CC & MIDI Destinations - External MIDI

The MIDI destinations are based on the MIDI standard assignments plus the ONE MIDI destination options as a reference. Refer to the MIDI mappings in the manual for the connected device in order to target the destination specific to the device. Many devices will be mapped differently to the assigned functions in the MIDI standard - especially in the higher CC range. MIDI Instrument definitions are useful for quick and accurate assignment.

MIDI Standard	CC #
Aftertouch	
Program Change	
Channel Pressure	
Pitch Bend	
Off	
Bank Select MSB	CC 0
Mod Wheel	CC 1
Breath Control	CC 2
Controller 3	CC 3
Foot Control	CC 4
Portamento Time	CC 5
Data Entry	CC 6
Channel Volume	CC 7
Balance	CC 8
Controller 9	CC 9
Pan	CC 10
Expression	CC 11
FX Control 1	CC 12
FX Control 2	CC 13
Controller 14	CC 14
Controller 15	CC 15
Gen Purpose 1	CC 16

MIDI Standard	CC #
Gen Purpose 2	CC 17
Gen Purpose 3	CC 18
Gen Purpose 4	CC 19
Controller 20	CC 20
Controller 21	CC 21
Controller 22	CC 22
Controller 23	CC 23
Controller 24	CC 24
Controller 25	CC 25
Controller 26	CC 26
Controller 27	CC 27
Controller 28	CC 28
Controller 29	CC 29
Controller 30	CC 30
Controller 31	CC 31
Bank Select LSB	CC 32
Mod Wheel LSB	CC 33
Breath Control LSB	CC 34
Controller 35	CC 35
Foot Control LSB	CC 36
Portamento LSB	CC 37
Data Entry LSB	CC 38

MIDI Standard	CC #
Chan Vol LSB	CC 39
Balance LSB	CC 40
Controller 9 LSB	CC 41
Pan LSB	CC 42
Exp controller LSB	CC 43
FX Control 1 LSB	CC 44
FX Control 2 LSB	CC 45
Controller 14 LSB	CC 46
Controller 15 LSB	CC 47
Gen Purp Ctrl 1 LSB	CC 48
Gen Purp Ctrl 2 LSB	CC 49
Gen Purp Ctrl 3 LSB	CC 50
Gen Purp Ctrl 4 LSB	CC 51
Controller 20 LSB	CC 52
Controller 21 LSB	CC 53
Controller 22 LSB	CC 54
Controller 23 LSB	CC 55
Controller 24 LSB	CC 56
Controller 25 LSB	CC 57
Controller 26 LSB	CC 58
Controller 27 LSB	CC 59
Controller 28 LSB	CC 60

Controller options are effectively undefined in the MIDI 1.0 standard. Other generic, non-specific CC are called general purpose. Values are MSB orientated which are typically used with MIDI gear. Any LSB values are stated as such.

MIDI Standard	CC #
Controller 29 LSB	CC 61
Controller 30 LSB	CC 62
Controller 31 LSB	CC 63
Damp/Sustain Pedal	CC 64
Portamento On/Off	CC 66
Sostenuto On/Off	CC 66
Soft Pedal On/Off	CC 67
Legato foot switch	CC 68
Hold 2	CC 69
Sound Controller 1	CC 70
Sound Controller 2	CC 71
Sound Controller 3	CC 72
Sound Controller 4	CC 73
Sound Controller 5	CC 74
Sound Controller 6	CC 75
Sound Controller 7	CC 76
Sound Controller 8	CC 77
Sound Controller 9	CC 78
Sound Controller 10	CC 79
Gen Purpose 5	CC 80
Gen Purpose 6	CC 81
Gen Purpose 7	CC 82

MIDI Standard	CC #
Gen Purpose 8	CC 83
Portamento ctrl	CC 84
Undefined	CC 85
Undefined	CC 86
Undefined	CC 87
Hi res velocity prefix	CC 88
Undefined	CC 89
Undefined	CC 90
FX 1 Depth	CC 91
FX 2 Depth	CC 92
FX 3 Depth	CC 93
FX 4 Depth	CC 94
FX 5 Depth	CC 95
Data Increment +1	CC 96
Data Decrement -1	CC 97
NRPN LSB	CC 98
NRPN MSB	CC 99
RPN LSB	CC 100
RPN MSB	CC 101
Undefined	CC 102
Undefined	CC 103
Undefined	CC 104

MIDI Standard	CC #
Undefined	CC 105
Undefined	CC 106
Undefined	CC 107
Undefined	CC 108
Undefined	CC 109
Undefined	CC 110
Undefined	CC 111
Undefined	CC 112
Undefined	CC 113
Undefined	CC 114
Undefined	CC 115
Undefined	CC 116
Undefined	CC 117
Undefined	CC 118
Undefined	CC 119
All Sound off	CC 120
Reset All Ctrls	CC 121
Local Ctrl On/Off	CC 122
All notes off	CC 123
Omni mode off	CC 124
Omni mode on	CC 125
Mono mode on	CC 126
Poly mode on	CC 127

CC120 - CC127 are reserved for channel mode messages which affect operating mode and not the sound.

# 7 Modulation

## Internal Sequencer Destinations

Internal destinations are parameters which exist in the currently selected sequencer that hosts the modulator being edited. As such the available parameters will be based on the Mode of the specific sequencer. Mod lanes, LFO and Ext CV are bipolar.

### All Modes

Parameter	LFO	Mod Lane	Mod Matrix Project MIDI	Mod Matrix Pattern MIDI	Mod Matrix CV
Off					
Velocity	Available	Available	Available	Available	Available
Pitch (scale quantized)	Available	Available	Available	Available	Available
Octave	Available	Available	Available	Available	Available
Gate	Available	Available	Available	Available	Available
CV Pitchbend	Available	Available	Available	Available	Available
Division Modulation	Available	Available	Available	Available	Available
Repeat Pulse Count	Available	Available	Available	Available	Available
Repeat Pulse Length	Available	Available	Available	Available	Available
Repeat Velocity Groove	Available	Available	Available	Available	Available
Repeat Time Groove	Available	Available	Available	Available	Available
Trig Probability	Available	Available	Available	Available	Available
CV Glide Time	Available	Available	Available	Available	Available
Keyboard Arp Division	Available	Available	Available	Available	Available
Keyboard Arp Voices	Available	Available	Available	Available	Available
Keyboard Arp Octave Type	Available	Available	Available	Available	Available
Keyboard Arp Gate Time	Available	Available	Available	Available	Available
Keyboard Arp Accent	Available	Available	Available	Available	Available
Keyboard Arp Euclidean Length	Available	Available	Available	Available	Available
Keyboard Arp Euclidean Pulses	Available	Available	Available	Available	Available
Keyboard Arp Repeat	Available	Available	Available	Available	Available
LFO 1 Wave	Available	Available	Available	Available	Available
LFO 1 Rate	Available	Available	Available	Available	Available
LFO 1 Amount	Available	Available	Available	Available	Available
LFO 2 Wave	Available	Available	Available	Available	Available
LFO 2 Rate	Available	Available	Available	Available	Available
LFO 2 Amount	Available	Available	Available	Available	Available

## All Modes Continued

Parameter	LFO	Mod Lane	MOD Matrix Project MIDI	MOD Matrix Pattern MIDI	Mod Matrix CV
Generator Pulse Length	Available	Available	Available	Available	Available
Generator Pulse Count	Available	Available	Available	Available	Available
Generator Rotation	Available	Available	Available	Available	Available
Generator Density	Available	Available	Available	Available	Available
Generator Invert	Available	Available	Available	Available	Available
Generator Note Range	Available	Available	Available	Available	Available
Generator Octave Range	Available	Available	Available	Available	Available
Groove Velocity Amount	Available	Available	Available	Available	Available
Groove Time Amount	Available	Available	Available	Available	Available
Random Perform Velocity	Available	Available	Available	Available	Available
Random Perform Octave	Available	Available	Available	Available	Available
Random Perform Gate	Available	Available	Available	Available	Available
Random Perform Repeat	Available	Available	Available	Available	Available
Random Perform Retrigger	Available	Available	Available	Available	Available
Random Perform Trig	Available	Available	Available	Available	Available
Random Perform Note	Available	Available	Available	Available	Available

## Mono Mode - Additional options

Parameter	LFO	Mod Lane	Mod Matrix Project MIDI	Mod Matrix Pattern MIDI	Mod Matrix CV
Accumulator Amount	Available	Available	Available	Available	Available
Accumulator Positive Limit	Available	Available	Available	Available	Available
Accumulator Negative Limit	Available	Available	Available	Available	Available

## Domino - Additional options

Parameter	LFO	Mod Lane	Mod Matrix Project MIDI	Mod Matrix Pattern MIDI	Mod Matrix CV
Accumulator Amount	Available	Available	Available	Available	Available
Accumulator Positive Limit	Available	Available	Available	Available	Available
Accumulator Negative Limit	Available	Available	Available	Available	Available

## 7 Modulation

---

### Poly Mode - Additional options

---



Parameter	LFO	Mod Lane	Mod Matrix Project MIDI	Mod Matrix Pattern MIDI	Mod Matrix CV
Poly Arp Division	Available	Available	Available	Available	Available
Poly Arp Octave	Available	Available	Available	Available	Available
Poly Arp Type	Available	Available	Available	Available	Available
Poly Arp Accent	Available	Available	Available	Available	Available
Poly Arp Euclidean Length	Available	Available	Available	Available	Available
Poly Arp Euclidean Pulses	Available	Available	Available	Available	Available
Poly Arp Euclidean Repeats	Available	Available	Available	Available	Available
Poly Arp Euclidean Rotation	Available	Available	Available	Available	Available

### Chord Mode - Additional options

---

Parameter	LFO	Mod Lane	Mod Matrix Project MIDI	Mod Matrix Pattern MIDI	Mod Matrix CV
Chord Root	Available	Available	Available	Available	Available
Chord Type	Available	Available	Available	Available	Available
Chord Voicing	Available	Available	Available	Available	Available
Chord Spread	Available	Available	Available	Available	Available
Chord Strum	Available	Available	Available	Available	Available
Chord Arp Division	Available	Available	Available	Available	Available
Chord Arp Octave	Available	Available	Available	Available	Available
Chord Arp Type	Available	Available	Available	Available	Available
Chord Arp Accent	Available	Available	Available	Available	Available
Chord Arp Euclidean Length	Available	Available	Available	Available	Available
Chord Arp Euclidean Pulses	Available	Available	Available	Available	Available
Chord Arp Euclidean Repeats	Available	Available	Available	Available	Available
Chord Arp Euclidean Rotation	Available	Available	Available	Available	Available

## Multitrack - Additional options

Parameter	LFO	Mod Lane	Mod Matrix Project MIDI	Mod Matrix Pattern MIDI	Mod Matrix CV
Euclidean Pulse	Available	Available	Available	Available	Available
Euclidean Rotation	Available	Available	Available	Available	Available
Pattern Density  kick	Available	Available	Available	Available	Available
Pattern Density  snare	Available	Available	Available	Available	Available
Pattern Density  hat	Available	Available	Available	Available	Available
Pattern X	Available	Available	Available	Available	Available
Pattern Y	Available	Available	Available	Available	Available
Pattern Chaos	Available	Available	Available	Available	Available

## Stochastic - Additional options

Parameter	LFO	Mod Lane	Mod Matrix Project MIDI	Mod Matrix Pattern MIDI	Mod Matrix CV
Note Probability	Available	Available	Available	Available	Available
Pitch Lock %	Available	Available	Available	Available	Available
Rhythm Lock %	Available	Available	Available	Available	Available
Positive Div %	Available	Available	Available	Available	Available
Negative Div %	Available	Available	Available	Available	Available
Higher Octave %	Available	Available	Available	Available	Available
Lower Octave %	Available	Available	Available	Available	Available

## Matriceal - Additional options

Parameter	LFO	Mod Lane	Mod Matrix Project MIDI	Mod Matrix Pattern MIDI	Mod Matrix CV
Note Interval	Available	Available	Available	Available	Available

## Saga - Additional options

Parameter	LFO	Mod Lane	Mod Matrix Project MIDI	Mod Matrix Pattern MIDI	Mod Matrix CV
Accumulator Amount	Available	Available	Available	Available	Available
Accumulator Positive Limit	Available	Available	Available	Available	Available
Accumulator Negative Limit	Available	Available	Available	Available	Available

## 7 Modulation

### Global Parameters Mod Matrix Options

Parameter	Optimal Range	LFO	Mod Lane	Mod Matrix Project MIDI	Mod Matrix Pattern MIDI	Mod Matrix CV
Off						
Seq Enable On/Off	0-127 >Offset = disabled, otherwise enabled	-	-	Available	Available	-
Seq Mute	0-127 >Offset = muted, otherwise unmuted	-	-	Available	Available	-
Seq Division	0-8 1Bar, 1/2, 1/4, 1/8, 1/12, 1/16, 1/24, 1/32, 1/64	-	-	Available	Available	-
Seq Direction	0-3 Fwd, Back, Alternate Random	-	-	Available	Available	-
Seq Scale	0-31 Based on scale list	-	-	Available	Available	-
Seq Root	0-11 C, C#, D, D#, E, F#, G, G#, A, A#, B	-	-	Available	Available	-
Seq Swing	-40 to +40	-	-	Available	Available	-
Seq Roll	0-8 Off, 1/4, 1/6, 1/8, 1/12, 1/16, 1/24, 1/32, 1/64	-	-	Available	Available	-
Seq Loop	0-127 from start	-	-	Available	Available	-
Seq Loop Release	Independent of value	-	-	Available	Available	-
Seq Time Stretch	-120 to +120	-	-	Available	Available	-
Seq Time Offset	-100 to +100	-	-	Available	Available	-
Track Init (& Euc Length)	0-127	-	-	Available	Available	-
Track End (& Euc Length)	0-127	-	-	Available	Available	-
MOD Lane Enable	0-1	-	-	Available	Available	-
MOD Lane Offset	-100 to +100	-	-	Available	Available	-
MOD Lane Division	0-8 1Bar, 1/2, 1/4, 1/8, 1/12, 1/16, 1/24, 1/32, 1/64	-	-	Available	Available	-
MOD Lane Init	0-127	-	-	Available	Available	-
MOD Lane End	0-127	-	-	Available	Available	-
Random Velocity	-100 to +100	-	-	Available	Available	-
Random Oct/Gate	-100 to +100	-	-	Available	Available	-
Random Trig Probability	0-100	-	-	Available	Available	-
Random Retrigger	-100 to +100	-	-	Available	Available	-
Global Tempo	0-127 offset set to lowest bpm with CC at 0	-	-	Available	Available	-
Global Fill	0-1	-	-	Available	Available	-
Global Reset	0-1	-	-	Available	Available	-
Random Generator	0-1	-	-	Available	Available	-
Pattern Reload	0-1	-	-	Available	Available	-
Tap Tempo	0-1	-	-	Available	Available	-
REC Toggle	0-1	-	-	Available	Available	-

### 7.10 Quick Assign

Quick assign is a feature which adds an additional layer of configuration for setting up modulation destinations. This speeds up the workflow of connecting a modulation source to a destination as well as giving more life and character to the sequence. Quick assign is available at the destination parameter level for all parameters that are declared as modulatable.

Simply hold [Shift] + long press (Knob) for a destination parameter and the quick assign pop-up page will enable quick configuration of the source modulation. Press [Back] to backup and exit.

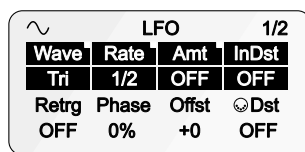

#### Modulatable Parameters

Parameters which can be set as a modulation destination are shown corner tagged on its page.

Example: LFO1 Wave, Rate, Amount are tagged as modulatable.



Quick assign and setup a modulation source. Hold [Shift] + Hold (Knob) > 1s for a modulatable parameter. See modulation destination list as a reference.

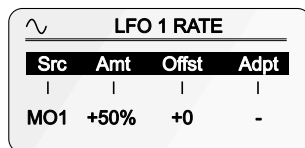

#### Quick Assign Page

The source and modulation settings that will be applied to the selected destination can be configured. The destination selected is displayed in the header.

Example: LFO1 Rate modulated by a patter Modulation lane 1.

Quick Assign Options			
Src	Amt	Offst	Adpt
Modulation Source	Modulation Amount	Modulation Offset	Adapt
Project or Pattern Modulation options. Includes Off, LFO 1 & 2, Random (S&H), Mod Lane 1-8, MIDI Learn.	Amount of modulation applied.	Amount of modulation offset applied.	Automatically aligns the ranges with the selected parameter, for example Velocity is +/-127 and octave is -/+7.

#### MIDI Learn

This is an option useful when quickly assigning external MIDI parameters as the source. With MIDI Learn selected, ONE will listen for incoming MIDI messages. Turn a knob on the external MIDI device and the parameter CC or Note will be recognised and assigned to the 'Src'.

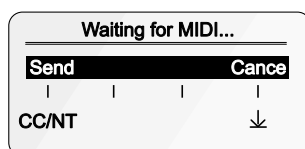

Adjust a connected controller or play a note. Tap knob 4 to cancel.



#### Pattern or Project

The source can be applied as a project source, where the source will remain even if a pattern is changed or pattern level which will only operate within the selected project.



# Arranger

The arranger is used to create, manage, and perform songs. A song is a complete production of multiple patterns representing the instruments assigned to sequencers and organized in a musical format. For example, assembling an intro, verse, chorus, and outro type of arrangement is a familiar song structure. The arranger has two primary uses. The first is creating a whole song sequence from start to finish, letting it play automatically through the patterns you've programmed. It is ideal for exporting a full production and making complete tracks. The other scenario is for live performances, ad-libs, and improvisations where patterns can be set up that loop indefinitely, and control of the progression is handled manually. Maybe a middle ground between total manual control and full song mode is another user case. It is worth exploring to see which approach fits your workflow best. The arranger is here to help structure, organize, and play full song arrangements. It's a tool that lets you stay focused on the music while OXI ONE takes care of the transitions in the background. It is essential to recognize that a prerequisite to using the arranger is to have a set of patterns saved first. The arranger will draw from a selection of existing patterns to build the composition, so good housekeeping and discipline in saving patterns earlier in the workflow is recommended. Up to 4 songs are available per project and these can be saved and loaded or will be saved when saving a project.

### 8.1 Arranger Terminology

The arranger is a tool that manages the complete process of assembling patterns into songs. Some new terminology is introduced and it will speed up your workflow to understand these topics early in this section.

#### **Song.**

A song is a state of an arrangement that can be saved as a complete composition created by assembling saved patterns into a musical structure. The song would therefore cover multiple instrument sections, controlled by each sequencer and laid out over time in relevant sections, for example intro, verse, build up, drop, breakdown etc. 4 Songs per project are available.

#### **Arranger.**

The OXI ONE tool used to build, manage and play a collection of patterns into the full arrangement. Often, this is called song mode. The arranger can be considered both a composition and a performance tool.

#### **Pattern.**

Pattern isn't a new term but is an important element of the arranger. A pattern is the core building block for musical passages and phrases. It contains the information that plays the instruments notes, parameters, timing etc.

#### **Slot.**

A slot is represented in the arranger by a column of pads which manages a specific section of patterns in a complete song composition. Each pad slot controls the pattern playback and transitions for each sequencer and its instrument.

#### **Clip Launch.**

Each pattern can be manually triggered and played in a slot or can be set to play automatically and repeat. The process of playing manually the patterns within the arranger slots is called clip launch. Great for improvisations or jamming sessions.

#### **Launch Quantization.**

Launch quantization applies only when the arranger is 'ON'. It is responsible for managing transitions between slots ensuring timing and sync is managed.

#### **Master Lane.**

The master lane is a single sequencer lane used as the primary controller for the other lanes. A lane is essentially the musical sections for an individual instrument represented by one of the eight sequencers over the duration of the song.

## 8.2 Songs & Arrangement Structure

Songs are created in the arranger. The arranger is used to build the compositions but also to playback an arranged song. The arranger must be 'ON' to play a song as opposed to playing an individual pattern. Each pattern and slot section can then be manually or automatically controlled with repeat count settings.

Example: Typical EDM Song Arrangement.

Arrangement Slots & Song Sections

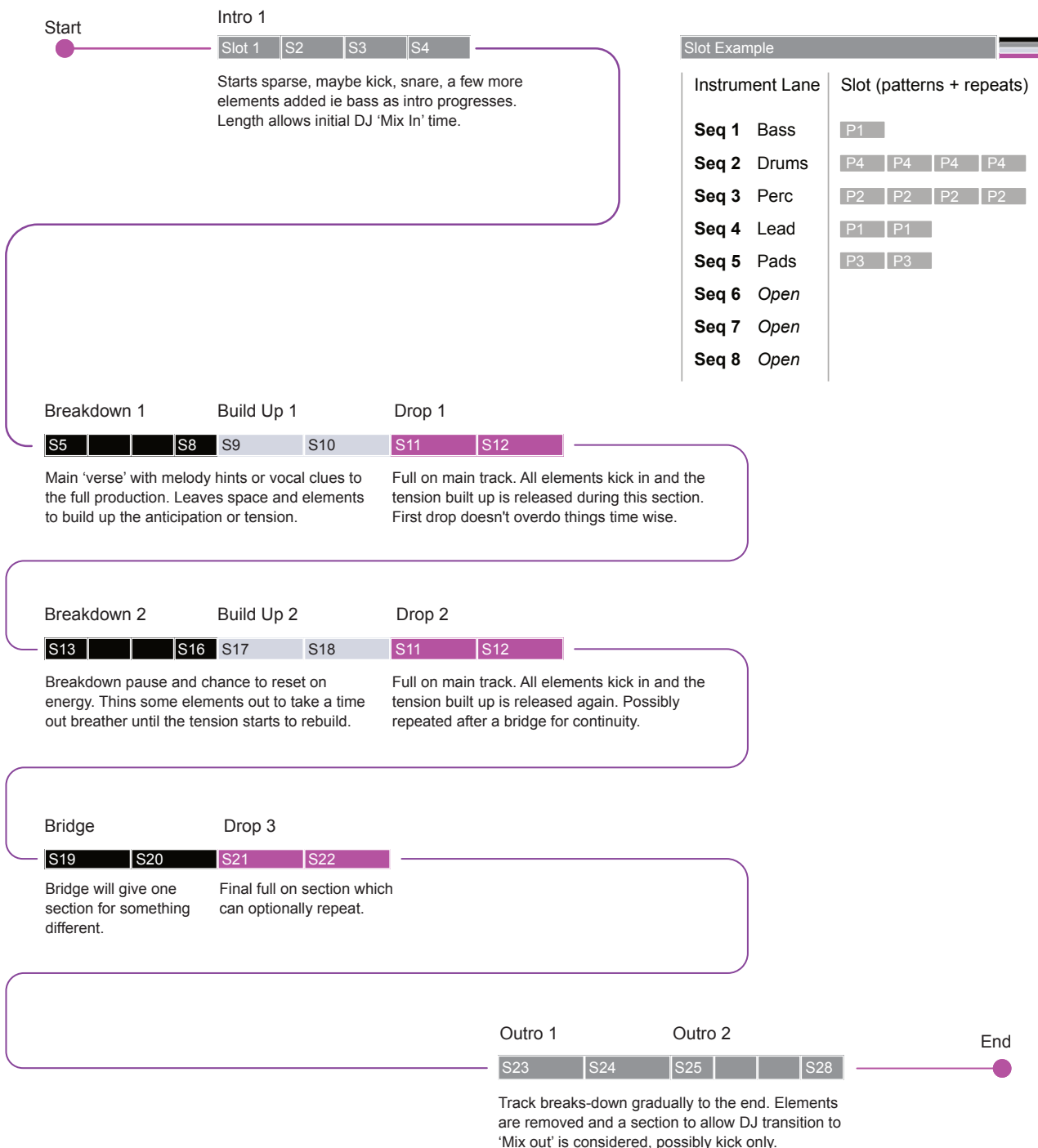

# 8 Arranger

## 8.3 Arranger View

The arranger is a tool for managing songs. This is accessed using the dedicated [Arranger] button. Selecting the arranger does not turn the song arranger playback on but only opens the tool. This is a separate step in the process and the arranger is turned 'ON' by holding [Shift] + [Arranger].

Select Arranger  Selects the arranger tool, pages and grid view in order to build and edit songs. Button will be lit white.

### Arranger Grid View.

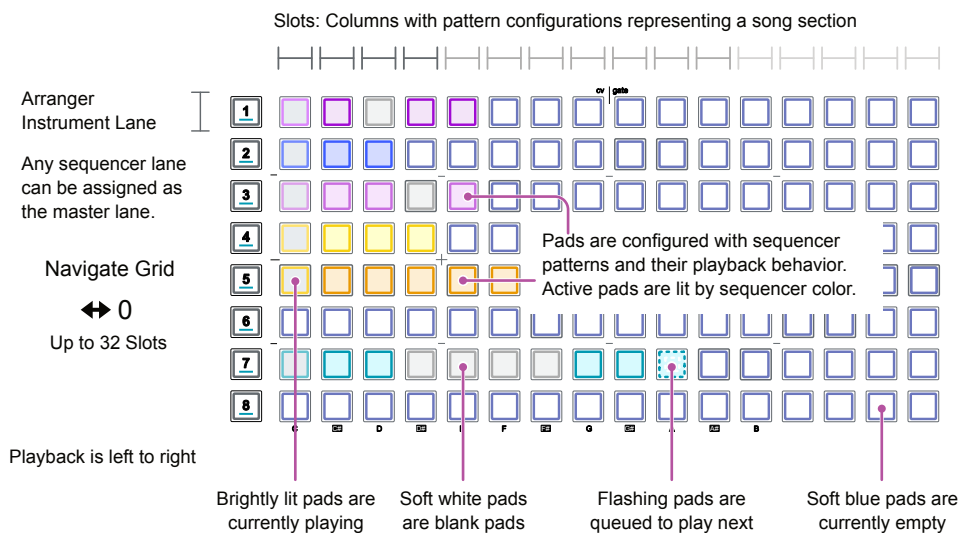

Blank  There is a difference between a blank slot pad and an empty pad. An empty pad is open and freely available. A blank pad is specifically placed to act as a spacer between patterns and also affects the playback behavior. Blanks are applied automatically when spacing out pattern slot pads.

Empty 

### Global Arranger Pages

Main Page 1.

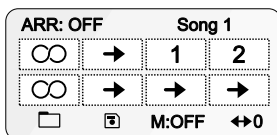

Editor Page 2.

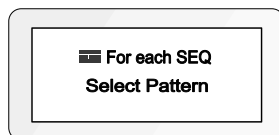

Navigate Pages



Button will flash when multiple pages exist. Press [Page] to navigate pages.

### 8.4 Creating and Editing a Song



The main arranger page is the place to select and structure patterns into full compositions or songs as well as clustering patterns into smaller groups for ad-libs and to use in live performances. A state of an arrangement is called a song. Songs can be saved and loaded individually and up to 4 can be saved with patterns and projects.



To edit a slot in the arranger, hold a pad to change the pattern, repeats, program change and bank settings. Press [Arranger] to set up the generic options and hold [Pad] for a pattern slot / instrument lane to edit the specific parameters.



Select Arranger  Selects the arranger tool, pages and grid view in order to build and edit songs. Button will be lit white.

#### Creating or Selecting a Song.

The currently loaded song will be the one edited when working in the arranger. This is shown in the header of the display. Songs cannot be renamed. Saving songs will save the project.

Save Song    In the arranger, tap (Save) knob 2 then turn knob 2 to select a song slot. Press (Save) knob 2 again to save the song to the selected slot.

Load Song    In the arranger, tap (Load) knob 1 then turn knob 1 to select a song slot to load. Press (Load) knob 1 again to load the selected song.

Clear Song  +  In the arranger, Hold [Shift] + [Paste] to clear the current song to a blank state. Undo is available.

#### Slot / Pattern Page.

While the global arrangement settings are available in arranger view, holding a slot pad will also give access to its pattern specific options. These are set specifically for each pattern slot when building the full song arrangement. Hold [Pad] to access these individual settings.

Best practice is to set the slot settings before constructing the arrangement. For example set repeats as the default which will then be applied when adding patterns to the track arrangement.



Hold [Pad] to edit pattern options

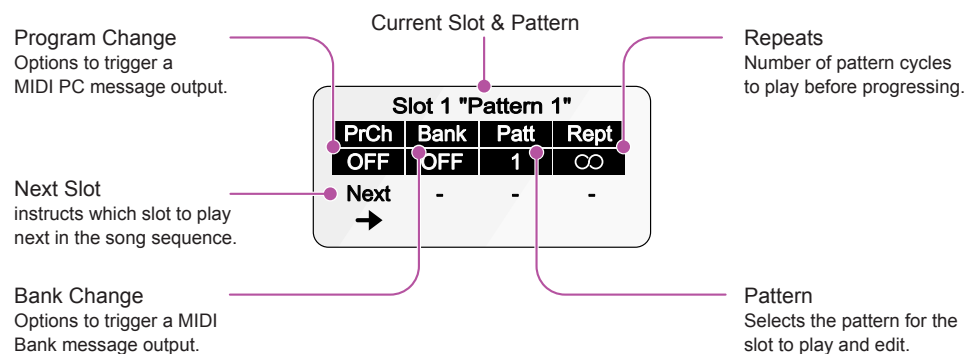

# 8 Arranger

## Constructing a Song with Patterns.

There are several ways to add patterns to a song. The approach that is used will depend on your personal preference and workflow. It is of course a prerequisite that patterns have already been created and that you have a documented or mental view of what patterns to select. These can be edited later if needed.

Remember, each row represents a sequencer arrangement lane 1-8. Each column represents the 1-8 pattern slots for each sequencer. Hold an arrangement slot to view the pattern assigned.

Assign Patterns  
By grid pattern



In the arranger view, open the pattern grid selection page by pressing [Page].

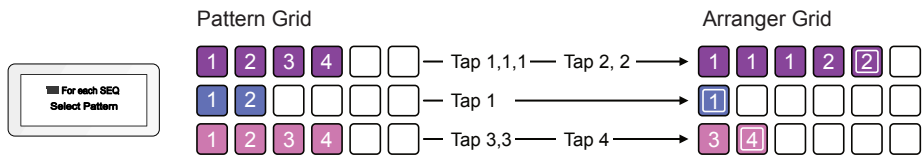

Press any pad to add it to the arranger. Patterns are added to the arranger in the order selected from its sequencer lane. Tap a pattern several times to continuously add. Multiple patterns can be iteratively selected.

Change a Pattern  
By grid pattern



To open the pattern grid, hold the arranger [Pad] + tap [Page] to open the pattern selection grid.

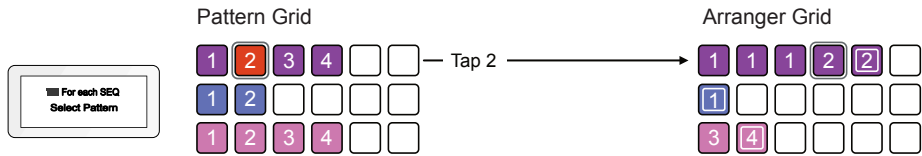

The current pattern will be lit red. Press any pad in the selected sequencer lane to choose a pattern for the selected arranger slot.

Change Pattern  
By slot number



Select a pattern by its pattern slot number from the current project and sequencer pattern list.

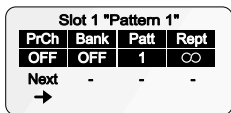

Current Slot and Pattern is displayed in the arranger slot display.

Create  
Slot Column



In the arranger view, create an entire slot column by holding [Arranger] + Tap any column [Pad].

The slots are created using the current default settings. So, for example, set the repeats prior to creating a slot column. Muted sequencers will create empty slots.

## Configuring How the Arrangement Slots Play.

Once patterns have been placed into the slots for each of the sequencer lanes, their individual behavior should be set to determine how each pattern will play. This process requires the parameters to be set for each slot. These include the repeat cycle and direction of progression. This activity is performed in the Arrangement view. Settings can be set prior or after creating pattern slots.

Hold Slot Pad



While holding an arranger slot pad the parameters for the pattern assigned to the slot are displayed and made available to edit.

Slot 1 "Pattern 1"			
PrCh	Bank	Patt	Rept
OFF	OFF	1	∞
Next	-	-	-
→			

Pattern - Slot Parameters			
PrCh	Bank	Patt	Rept
Program Change	Bank Change	Pattern Assigned	Pattern Repeat Behavior
Sets the program change options. Sends the MIDI PC message 2 tics before the pattern transition.	Sets the banks select CC message. Sends a MIDI CC#0 or #32 message 2 tics before the pattern transition.	Pattern number for the selected sequencer slot to launch.	Sets the behavior of how many times pattern will play. This is the number of repeat cycles between 1-19 or play infinitely.
Next			
Pattern Transition			
Selects the next slot to play. Can be the next, prior or 1 <sup>st</sup> slot as well as random or other which is similar to random.			

## Repeat.

Repeat sets how the pattern plays before it moves to the next pattern slot. Setting repeat to 'Infinite' which will constantly repeat without progressing. This is symbolised by the infinity icon. Another option is to set to 'Off' which sets the pattern as empty and a such the slot will be skipped when playing the arrangement. The number of playback cycles can also be set between 1-19. This can be set for slots with a pattern or slots with no pattern assigned which then become blank slots and are lit white. Blank slots will still be activated for 1 bar of 16 step duration (1/16<sup>th</sup>) and the set number of repeats but without playing an actual pattern notes or modulation. The difference between blank slots and empty slots is that empty slots are skipped while blank slots are useful to hold the arranger position playback silently at the selected slot for a defined period or infinitely until manually progressed.

Repeats



Hold [Pad] + Tap (Rept) Knob 4 to quickly toggle between 1 and Infinite setting. Hold [Pad] + Turn (Rept) Knob 4 to select an specific option.

Infinite



Plays indefinitely with no repeat countdown. Progression is performed by manually tapping another slot pad. Can be used for blank slots which are lit white.

Countdown

1-19



Plays and counts down the number of repeats. Can be progressed earlier by manually tapping another slot pad. Can be used with blank slots, lit white.

Off

OFF





Off sets the pad slot to 'empty' meaning that arrangement playback will skip this step in the song progression.

# 8 Arranger

## Next.

Next sets the transition behavior of the slot and determines which slot is played next in the song sequence. Once the pattern and its repeats are completed the song will progress to the next slot.

Next  +  Hold [Pad] + Tap (Next) Knob 1 to toggle between PrCh and Next options. With 'Next' selected turn (Next) Knob 1. Hold knob to reset.

### Next Slot



During the slots last repeat cycle, the next slot will flash signifying that it is cued. When the repeats and pattern are complete, the next slot available in the song sequence will play next.

### Previous Slot

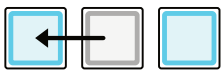

During the slots last repeat cycle, the prior slot will flash signifying that it is cued. When the repeats and pattern are complete, the previous slot in the song sequence will play next.

### First Slot **1st**



During the slots last repeat cycle, the first slot will flash signifying that it is cued. When the repeats and pattern are complete, the first slot in the song sequence will play next.

### Random Slot



During the slots last repeat cycle, a random slot will flash signifying that it is cued next. When the repeats and pattern are complete, the cued slot will play next. Randomly plays any pattern.

### Other Slot **OTHR**



During the slots last repeat cycle, a random slot will flash signifying that it is cued next. When the repeats and pattern are complete, the cued slot will play next. Does not repeat its own pattern.

## 8.5 Playing and Controlling a Song

Press [Arranger] to open the arranger options. However to play a song arrangement, the arranger must be turned on / armed. The arranger will automatically disarm when stopped. Saved patterns are loaded when playing songs. As such it is important to save ant edited patterns to avoid loss.

Arranger on or off  
[Shift] + [Arranger]  +  Press [Shift] + [Arranger] to turn on.  
Arranger button is lit blue when armed.

To play a song the arranger must be turned 'ON' to arm it before pressing play.  
The arranger will automatically turn off and reset to unarmed when it is stopped.

**Play the Song**  
Tap [Play]  Press [Play] to play the selected song. The arranger must be set to On/Armed in order to play a song as opposed to only the patterns.

**Stop the Song**  
Tap [Stop]  Press [Stop] to stop and reset the selected song. The arranger will automatically turn to Off/Disarmed.

### Arranger: Main Page 1.

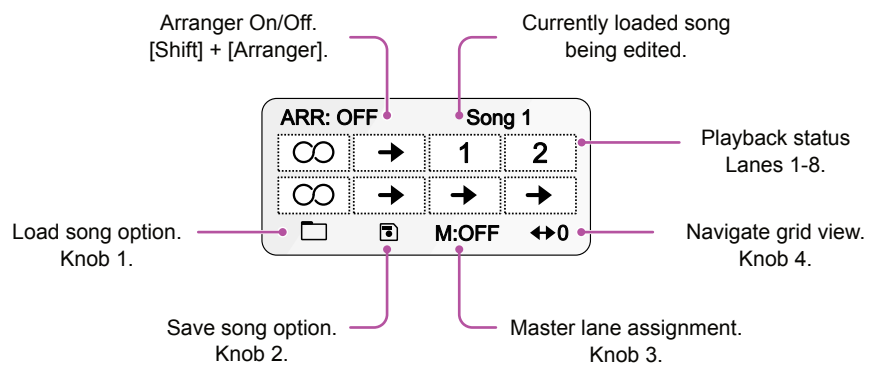

Lanes represented by the sequencer row.  
The display shows lanes ordered as below.

1	2	3	4
5	6	7	8

### Page Lane Symbols



Current slot is operating in an infinite playback cycle.



Transition to the next cued pattern imminent. Currently playing the last repeat cycle for the slot.



The 'M' indicates the lane is assigned as the master lane.



Repeat playback cycle countdown for the pattern before progressing.

Patterns in an infinite cycle will continue to play indefinitely unless another slot is manually selected.

Patterns set on a repeat cycle will automatically progress to the next slot in the song. They can also be manually transitioned.

# 8 Arranger

Pattern playback behavior can be controlled individually. Remember each pad represents a pattern for the arranger instrument lane assigned to play or can be setup to play a set number of times before progressing, infinitely or not at all. Patterns are played in the slot columns left to right or as manually selected.

Play slot.  
Tap [Pad]  While playing, tap the pad for the slot and instrument lane to play. Playback will start based on the launch quantization. **ONE** manages the pattern synchronisation and timing in the background.

Play slot column.  
Tap [Pad]  +  While playing, hold [Shift] + tap the pad to cue and play full column.

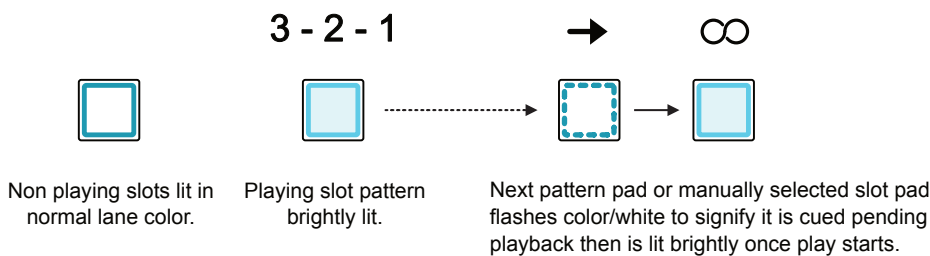

### Launch Quantization

OXI **ONE** Arranger manages the synchronization and transition of patterns throughout the song in the background, simplifying the user experience when playing and creating songs. The function that manages this is arranger launch quantization, and the arranger must be set to On/Armed for it to be active.

The arranger launch quantization setting is found in the 'Project' configuration, accessed with [Shift] + [Perf]. Options are P.End - Pattern End, ½ Bar, 1 Bar, 2 Bars, 4 Bars, 8 Bars, 16 Bars, 32 Bars.

Launch quantization sets the number of bars, based on the internal clock, to complete one pattern repetition cycle. The launch quantization is displayed as a progress bar on the arrangement main page. This function controls the transition timing between patterns in a song.

Note that an alternate version exists called global or load quantization, which is applied when the arranger is off for things such as pattern loading behavior.

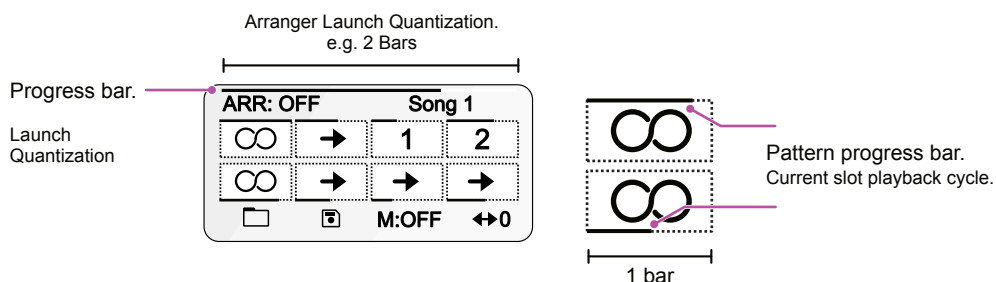

### 8.6 Master Lane & Clip Launch

A master lane is available for each song and can be assigned to any one of the sequencer lanes. A master lane operates as the primary controller for all other lanes. The master will dictate the progression of all slots ignoring repetition and pattern length settings of other lanes. For example, selecting a slot to play on the master lane will also select the equivalent slots on other lanes.

Master Lane  Turn Knob 3, (M:OFF) to select a master lane. Double tap to reset its value to OFF.

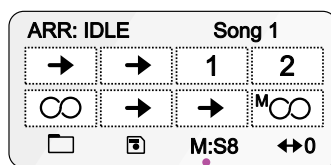

Options are Off, Lanes 1-8. An 'M' Symbol will also indicate the selected lane. Example, lane 8.

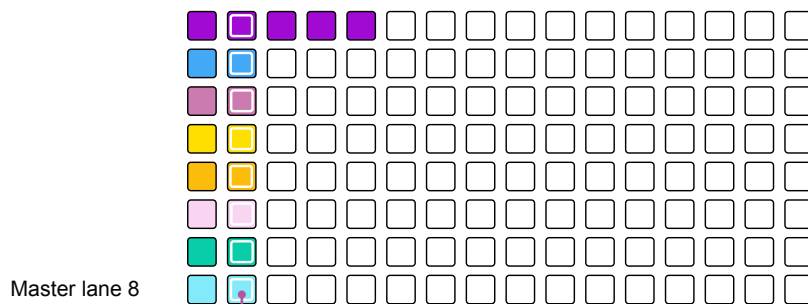

Master lane assignment.

Repeat settings and pattern lengths are ignored. Only the master lane controls the progression.



Playback of the song slots will be synchronised to the master track.

Clip Launch  Tap any arrangement slot [Pad]s to launch pattern playback manually. Transition is governed by the launch quantization. Tapping a slot pad on the master lane will trigger its playback and the slot on all other lanes.

Pattern Override  +  While the arranger is on and a song is playing, Hold [Load] + [Pad] for the pattern to change.

## 8.7 Program Change & Bank Change

As well as controlling pattern playback, each slot also has the option of being set to trigger a MIDI Program Change or PC message. Program changes are used to change presents, patches or sounds in a destination device.

Most presets are organised in banks. A bank change message can also be configured for each slot. The MIDI standard protocol uses Control Change CC#0 MSB or CC#32 LSB to initiate a bank change.

### PrCh

- = Use pattern PC value.
- Off** No PC transmitted.
- 1-128** PC Message value.

Slot 1 "Pattern 1"			
PrCh	Bank	Patt	Rept
OFF	OFF	1	∞
Next			
→			

### Bank

- = Use pattern bank value.
- Off** No bank transmitted.
- 1-128 L or M** PC LSB or MSB message.

Arranger Grid

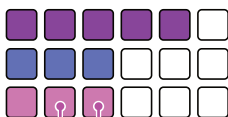

MIDI Channel should be set for the sequencer. Blank slots can also send PC and Bank changes without playing a pattern.

Slot will trigger a PC and Bank message 2 clock tics before activating the next pattern

Pattern will play the new preset or sound activated by the program and bank change.

Program Change and Bank options are also available for each sequencer pattern. Default is '=' to use the pattern settings. These are set with [Shift] + Seq [1] + [8] and the PC and Bank options found in settings pages 1 and 2 respectively.

### Incoming Program Change

The pattern column slots, displayed on the grid in page 2 of the arranger, can be selected using incoming MIDI PC messages. The columns are numbered from left to right so the first column is selected with PC 1, second column PC 2 and so forth.











As a prerequisite, set the MIDI Channel used for incoming program change in the configuration settings: Config > MIDI > PC (Program Change) receive global Channel

— Note —

It may need some experimentation and testing with the external device in order to match the program change and bank change messaging. Some preset structures start at 0, some at 1 and some may not count to 128. Try variations in order to find the right alignment between ONE and the device.

## 8.8 Editing Slots

The pads on the grid represent the patterns in the song slot. Each slot can be shifted left or right on the grid, copied, pasted and cleared. The sequencer lane color matches the sequencer color and can be changed in the main sequencer view. The following edits are performed in the arranger.

- |                  |   |   |   |   |
|------------------|---|---|---|---|
| Copy Slot        |    | + |    | Hold [Copy] + [Pad] to copy the pattern slot.<br>Only individual pattern slots can be copied.         |
| Paste Slot       |    | + |    | Hold [Paste] + [Pad] to paste the previously copied pattern slot into the same lane.                  |
| Clear Song       |    | + |    | Hold [Shift] + [Paste] to clear the entire song.  |
| Shift Slot Right |   | + |   | Hold [Pad] + Page [64] to move the pattern right.<br>Also moves or rearranges blanks and empty slots. |
| Shift Slot Left  |  | + |  | Hold [Pad] + Page [16] to move the pattern left.<br>Also moves or rearranges blanks and empty slots.  |



# Connectivity

The connectivity options for OXI ONE are what makes it the perfect device as a centre piece in the studio, for a live rig, or anywhere that inspiration strikes. Firstly, ONE has 8 CV inputs and 8 Gate outputs which can be easily configured to connect with analog gear such as Eurorack modules or desktop devices. It is equally comfortable controlling monophonic modules and polyphonic voices or simply modulating an external control. The CV and Gates can be configured or set on/off on the fly, allowing the grid to act as a performance interface. An analog clock, reset and 2 CV inputs are also available. MIDI inputs and outputs are also supported including CC, but not NRPN. CC mappings are shown in the LFO Modulation section. This can be set up using the TRS connectors directly with a stereo cable or the TRS to MIDI DIN Type-A adapter. In addition, MIDI is available over the USB-C connection as well as the BLE - Bluetooth Low-Energy wireless interface. The interface options are, therefore, comprehensive and versatile. But there's more! The MIDI ports can be expanded further using OXI Split, and the OXI Pipe interface connects seamlessly to a Eurorack system using the HDMI pipe connection. This creates a powerful and flexible sequencer ecosystem, bringing together many devices and creating almost infinite configurations.

## 9.1 CV & Gate Output Configuration

OXI ONE has 8 CV and 8 Gate outputs which can be configured for each of the sequencers. The CV output range is limited by the hardware to -3V to 5V. The CV Gate configuration can be setup using the grid pad configurator and as this configuration covers all sequencers it is saved with the project.

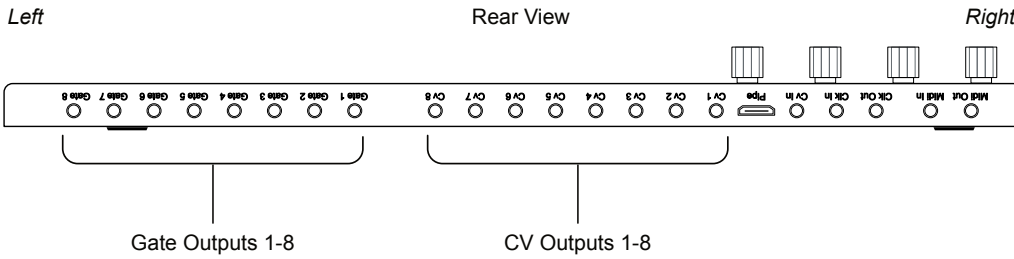

CV Gate  +  Open the CV Gate configuration menu. Hold [Shift] + press [Gen].

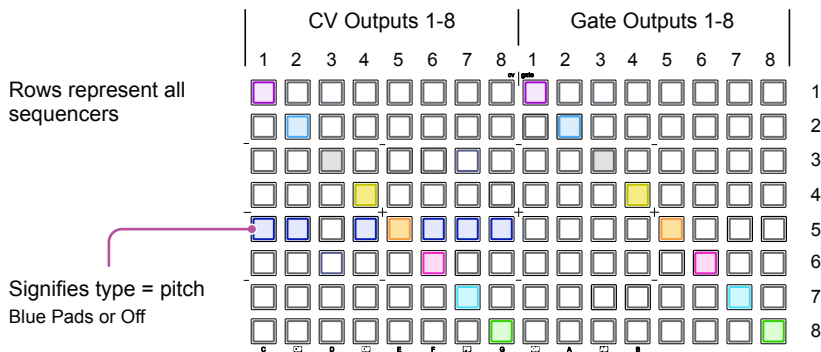

 Tap a pad to activate or deactivate the CV or Gate output for sequencers 1-8. The display will indicate current setting.

Example shows the CV & Gate outs 1 configured for sequencer 1, CV & Gate outs 2 for sequencer 2, through to CV & Gate 8 set to sequencer 8, all CV set to pitch, shown as blue pads, except CV3 with the pad unlit.

While playing a pattern the pad columns representing the outputs will indicate any real-time activity.

Each of the outputs can be configured using the available parameter options for the CV and the Gate. The output edited is selected using the pad columns. Press a pad for the selected sequencer to edit either CV or Gate out.



In the CV Gate grid, tap a pad to activate or deactivate the CV or Gate output for sequencers 1-8. The display will indicate current setting and enable the parameters to be edited for the selected step

### CV options

displayed when tapping a column 1-8 pad  
Selected sequencer is also displayed

CV 1 - SEQ 1			
Type	Voice	Ofst	Frmt
Pitch	1	Ost	V/Oct
-	-	-	-
-	-	-	-

### Gate options

displayed when tapping a column 9-16 pad  
Selected sequencer is also displayed

GATE 1 - SEQ 1			
Type	Voice	-	Mode
Trig	1	-	VTrig
-	-	-	-
-	-	-	-

Selecting a pad will turn the output for the sequencer on or off. The output behaviour will also need to be set up. This starts by setting a 'Type' for the CV output which will also determine what additional parameters are available to setup.

The CV options that are available are Pitch, Velocity, Trig Envelope, LFO 1, LFO 2, MOD 1 to MOD 8. The physical output voltage range for the CV outputs is -3V to +5V. This is adjusted depending on the configured output and setup needs considering based on the destination device.

The Gate options that are available are Trig, Clock, Accent and Threshold.

## ► Configuring the CV & Gate Output

1. Open the CV Gate configuration. Hold [Shift] + tap [Gen]. The grid represents all sequencers by row and the CV and Gate in the columns.
2. Tap a pad to select the output, indicated by the lit pad. The first 8 columns represent CV 1-8 and the next 9-16 columns represent the Gate outputs. Tapping the pad therefore links the output from the sequencer to the selected CV or Gate output.
3. Hold a pad to configure the CV or Gate output behaviour. The settings will be displayed, labelled for the selected CV or Gate and the sequencer.
4. Adjust the parameters using the knobs for each function.
5. Also consider the CV / Gate Voicing allocation settings found in the 'Config > Analog' options. Sets the behavior of how the outputs are allocated polyphonically.
6. Save the project in order to save the configuration.  
Quick save by holding [Shift] + press [Save].

## 9.2 CV Output Options

The output behaviour needs to be set up. This starts by setting a 'Type' for the CV output which will also determine what additional parameters are available to setup. The CV options that are available are Pitch, Velocity, Trig Envelope, LFO 1, LFO 2, MOD 1 to MOD 8. The physical output voltage range for the CV outputs is -3V to +5V. This is adjusted depending on the configured output and setup needs considering based on the destination device.

### CV Output Types

Refers to the type of output that the CV will be used for. The options that are available are Pitch, Velocity, Trig Envelope, LFO 1, LFO 2, MOD 1, MOD 2, MOD 3, MOD 4. The configuration of each will offer a set of parameters exclusive to the type selected. Type is selected with Knob 1.

### Voices

Think of a voice as representing a track or note output from a sequencer and is the parameter that controls how polyphonic notes are played alone or together. For example a mono mode sequencer only uses one note while a chord mode sequencer can use up to 8. The voice options are therefore sequencer mode dependant. For analog outputs, each voice will require an allocated physical CV / Gate output. So a triad chord will require 3 x CV Outputs. But chords are not only triads and more voices may be needed.

Mode	Mono	Poly	Multi	Chord	Stochastic	Matriceal	Domino	Saga	MIDI Player
Max Voices	1	7	8	8	1	4	4	4	7

### Voice Allocation Rules - Config

OXI ONE also has to take care of the behavior of the voice allocation under various scenarios. For example, how are voices allocated if four notes are played when only 3 x CV/Gates are assigned? Which notes take precedence when changing the chords? Which notes to steal to re-allocate a new note? The rules applied for voice allocation are defined in the Config menu, under the Analog sub-menu. The parameter to edit is 'CV & Gate voice allocation'.

Config > Analog - 'CV & Gate voice allocation'

Option	Notes stolen	Description
LRU	Least Recently Used	If a new note is played while others in a chord are still active, the output voices needed may exceed the available CV/Gate voices allocated. With a setting of LRU, the oldest note will be cancelled, also called 'stolen' and replaced with the newest note played. This behavior continues as notes are added to existing chords.
LOW	Lowest note	If a new note is played while others in a chord are still active, the output voices needed may exceed the available CV/Gate voices allocated. With a setting of LOW, the lowest active note value will be cancelled or 'stolen' and replaced with the newest note played. This behavior continues as notes are added to existing chords.
Unison	Sort by Last played	All available CV and Gates voices configured for the sequencer play in unison for single notes. Further notes are divided among the voices to maximize the use of the assigned CVs and Gates. If there are more notes than the available CVs or Gates, the voices will still be sorted by the last played.

**Type - Pitch**

Sets the CV output to control pitch of an external device. The output requires the voltage to be calibrated to the pitch. This ensures that the sequenced notes in ONE play on the external device as the correct note. The calibration varies depending on the device being controlled.

CV 1 - SEQ 1			
Type	Voice	Ofst	Frmt
Pitch	1	0st	V/Oct
-	-	-	-
-	-	-	-

Type set to pitch along with associated parameter options. Turn (Type) Knob 1 to select the option.

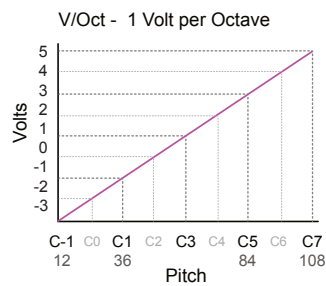

**Hz/Volt**

An alternative pitch tracking model is the Hertz per volt calibration, a linear calibration typically used by Korg and Yamaha. Output is calibrated at 0v to +5V.

**1.2Volt**

Another supported model is 1.2 Volt pitch tracking. This is typically used in Buchla systems. Designed to cover an even 0.1V semitone representation in a western 12 note scale. Output is calibrated at 0V to +5V.

V/Oct is typically used by modular, semi-modular, Eurorack, Moog devices. OXI ONE CV outputs are calibrated to the -3V to +5V range across C-1 to C7. A re-calibration can be performed but this is not recommended for normal operation as ONE is already pre-calibrated. The diagram above is shown with the MIDI note values for reference and simplified for illustration purposes as frequency perception of pitch in reality is logarithmic.

Pitch Settings			
Type	Voice	Ofst	Format
Pitch	Voice Index	Note Offset	Voltage format
Pitch is the configured output to control as defined by the available parameter settings.	Voice index based on sequencer mode. For example, Mono has 1 voice, chord up to 8.	Adjust the pitch by applying an offset in semitones. Range is -48 to + 48 semitones.	Format set to match the receiving device. Eurorack V/Oct, Korg Hz/Volt, Buchla 1.2V.

## Type - Velocity

The velocity value of the steps can be transmitted out through CV. This is a directly accessible feature when working with the CV Gate options. This is useful for adding some expression or modulation to an analog device for example controlling note attack or release or decay.

Configuring a CV output for velocity is similar to setting up pitch. The grid is used to assign outputs to sequencers in CV Gate view. Each velocity output requires 1 voice and hence 1 CV output.

CV 1 - SEQ 1			
Type	Voice	Gated	-
Vel	1	OFF	-
-	-	-	-
-	-	-	-

Type is set to velocity, along with associated parameter options. Turn (Type) Knob 1 to select the option.

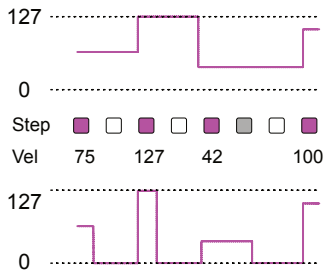

### Gated - OFF *Default*

The velocity CV output will be retained at the value set by the last note. Any change to the velocity value will only be triggered when a new note plus velocity value is recognised.

### Gated ON

Velocity will be output only for the duration of the individual or tied note. When the note ends the velocity will be set to 0. Any new notes will update the velocity.

Velocity Settings			
Type	Voice	Gated	
Velocity	Voice Index	Gated Velocity On/Off	
Velocity is the output to control as defined by the available parameter settings.	Voice index based on sequencer mode. Velocity needs 1 voice.	Retains velocity between any played notes or resets to zero each time a note ends.	

**Type - T.Env**

The trigger envelope acts as an ADSR - Attack / Decay / Sustain / Release style CV output envelope. The attack and sustain can be edited. This is useful for adding some modulation or control to an analog device for example controlling a voltage controlled amplifier, low pass gate or filter cutoff. The envelope is triggered by a step note and its amplitude is proportional to the velocity meaning 127 for note velocity will output the maximum 5V.

Configuring a CV output for T.Env is similar to setting up velocity. The grid is used to assign outputs to sequencers in CV Gate view. Each envelope output requires 1 voice and hence 1 CV output.

CV 1 - SEQ 1			
Type	Voice	Attk	Sust
T.Env	1	0	0%
%Amt	-	-	-
100%	-	-	-

T.Env selected as type and associated parameter options. Turn (Type) Knob 1 to select the option.

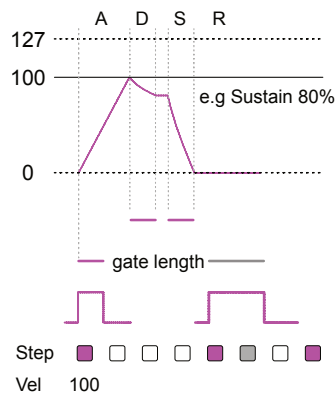

Attack - time 0-100

Attack time can be set manually in the settings or as an LFO or Mod lane destination. Time to reach maximum.

Sustain - level 0-100%

Set as a percentage of the max amplitude of the envelope. Amplitude is set by the default velocity or the actual, altered velocity value for example after modulation. The decay curve is determined between max and the sustain level.

Decay / Release - time

Both decay and release are automatically derived from the gate length for the triggering step. When a note is tied, the release value is based on the last note triggered by a tie..

T.Env Settings			
Type	Voice	Attk	Sust
T.Env	Voice Index	Attack time	Sustain level
Envelope is the output to control as defined by the available parameter settings.	Voice index based on sequencer mode. The envelope needs 1 voice.	Time for the envelope to reach full value. Full value determined by the triggered note velocity.	Level that the envelope is held while the note is active. Set as a % of the amplitude.
<b>%Amt</b>			
Envelope Amount			
Sets the amount of envelope applies to the trigger output.			

Modulating gate and velocity will also affect the decay and amplitude. This could be by using modulation lanes. LFO's or by also using randomization.

### Type - LFO & MOD

The modulation functions of LFO and MOD operate in the CV outputs in a similar way. There are 2 LFOs and the 8 modulation lanes per sequencer mode which can be used to send modulation to CV outputs. Each would be selected individually. The grid is used to assign outputs to sequencers in CV Gate view.

CV 1 - SEQ 1			
Type	Offst	-	-
LFO 1	0	-	-

LFO 1 or 2 is selected as type  
Turn (Type) Knob 1 to select the option.

CV 1 - SEQ 1			
Type	Offst	-	-
MOD 1	0	-	-

MOD 1-8 are selected as type  
Turn (Type) Knob 1 to select the option.

### Modulation CV Output example

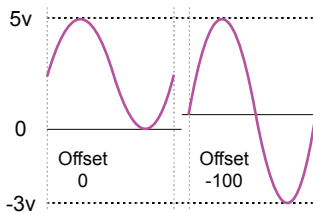

### Offset

The CV output from LFO and MOD modulation will cover a 0-5V range, unipolar at 0 offset. The ONE hardware range is 8V, starting from -3V up to +5V. To get the output to operate over the full -/+ve range then offset should be adjusted. Setting an offset to -100 will operate over the -3V to 5V range. A +40 offset would typically cycle an LFO around a +1V centre ref, over a -/+4V range.

T.Env Settings	
Type	Offset
LFO or MOD	Offset
Selects an LFO or Modulation lan source to output to the CV port.	Adjust the voltage range of the modulation output.

The LFO settings can be edited in the LFO pages. The parameters will affect the behaviour of the CV output although the LFO parameter destination is independent and therefore is not affected by the CV routing set up in the CV Gate page.

### 9.3 Gate Output Options

Gates are typically used to trigger an event. For example to trigger a note on signal. So for a mono mode sequencer 1 note can trigger 1 gate and 1 CV to activate the note. For chord mode, say triggering a 3 note triad, the chord would need 1 gate to trigger all of the notes and 3 x CVs to set the value of each note in the chord. Having said that gates can also be set to multiple voices if desired, limited by the sequencer mode.

As well as note triggers, the gates in ONE can be configured as a clock, accent or as an LFO threshold using the gate 'type' parameter.

The setup process for gates is the same as for CVs where the grid is used to activate and deactivate the outputs and the parameters can be set with the knobs.

CV Gate  +  Open the CV Gate configuration menu.  
Hold [Shift] + press [Gen].



In the CV Gate grid, tap a pad to activate or deactivate the CV or Gate output for sequencers 1-8. The display will indicate current setting and enable the parameters to be edited for the selected step

The gate voltage output is typically at 0-5V. default This can also be set to 0-10V. The option to set this globally for all gate outputs is found in the configuration settings. Config > Analog > Gate V Out.

The voice can be selected on many of the options. For multitrack mode sequencers a track can be selected as the alternative option to voice.

### Type - Trig

Sets the gate output behavior when controlling a trigger. The trigger will remain active while a note is held. Gates can be configured to operate at 5V or 10V and has two operating formats which allows the output to be matched to one of the two main standards.

GATE 1 - SEQ 1			
Type	Voice	-	Mode
Trig	1	-	VTrig
-	-	-	-
-	-	-	-

Trig selected as type and associated parameter options. Turn (Type) Knob 1 to select the option.

### Gate Triggers

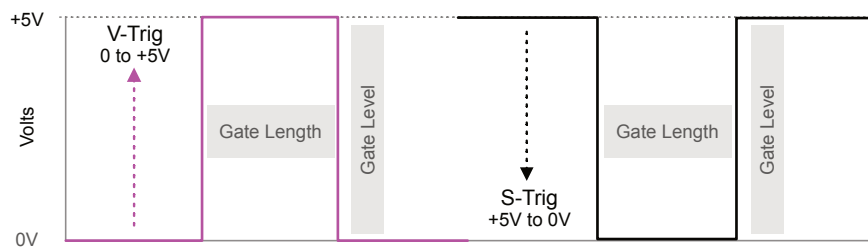

V-Trig. The output is high when triggering. The range is typically 0V to 5V. When a trigger is off the voltage will remain low.

S-Trig. The output is low when triggering. The range is typically 5V to 0V. When a trigger is off the voltage will be high. Can also be used as an inverted gate.

Trig Settings		
Type	Voice or Track	Mode
Trig	Seq Voice / Track	Voltage format
Sets the output to operate as a trigger. Typically used for notes.	Depends on sequencer mode. Selects a voice or track to monitor.	Format set V-Trig, high represents a trigger. This is default. S-Trig when low is a trigger.

**Type - Clock**

Sets the gate output to operate as a clock. A pulse is output based on the defined rate configured in the settings. The rate value is independent from other sequencer rates.

GATE 1 - SEQ 1			
Type	-	Rate	-
Clock	-	1/16	-
-	-	-	-
-	-	-	-

Clock selected as type and associated parameter options. Turn (Type) Knob 1 to select the option.

Clock Pulses

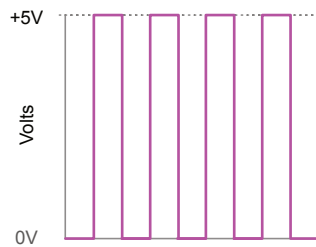

Clock pulse has 50% duty cycle, duration of pulse based on the rate. So for example, with the default rate of 1/16<sup>th</sup>, each pulse width is 1/32<sup>nd</sup> duration.

Rate options  
Bar, 1/2, 1/4, 1/8, 1/8t, 1/16, 1/16t, 1/32, 1/32t, 1/64

Clock Settings			
Type			Rate
Clock			Clock speed
Sets the output to operate as a clock pulse.			Independent rate from sequencer, but set in time divisions.

The sequencer must be running for the clock output to be active.

### Type - Accent

Accents allows a gate output to be configured to trigger when the velocity value exceeds a defined value. This allows destination parameters such as triggering hat or rim sound, sub bass or affecting a parameter. The output will only be triggered when the threshold of the velocity of a note in the current pattern is exceeded. This can be set per voice or aligned to a track in multi track mode.

GATE 1 - SEQ 1			
Type	Voice	Trhld	-
Accnt	1	64	-
-	-	-	-
-	-	-	-

Accnt selected as type and associated parameter options. Turn (Type) Knob 1 to select the option.

### Accent Trigger

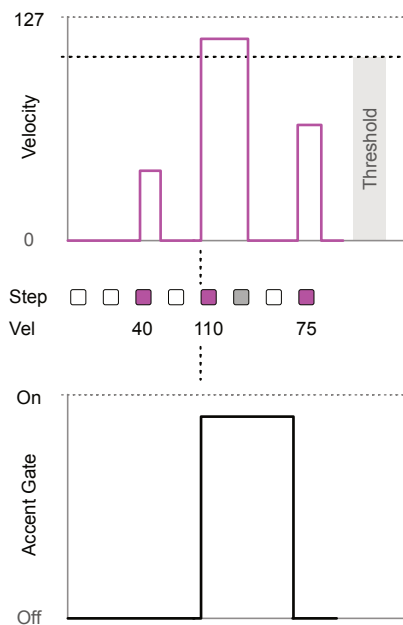

The accent function monitors the velocity of the notes in a sequencer pattern. The track or voice can be assigned for the accent monitoring.

When a velocity value for a note in the sequencer pattern exceeds the threshold a gate is triggered. The trigger will stay high until the next trigger update. If the next trigger update is below the threshold, it will reset.

Accent Settings			
Type	Voice / Track	Trshld	
Trig	Seq Voice / Tracks	Threshold	
Sets the output to operate as a trigger. Typically used for notes.	Selects a voice or track to monitor. The velocity value is checked against threshold value.	Sets the threshold value for the velocity check. When exceeded the gate will be triggered.	

**Type - Threshold**

Threshold allows a gate output to be configured to trigger when the value of an LFO or Mod lane source exceeds a defined value. This allows destination functions to be triggered based on the modulation value, for example turning on a filter if modulation is above a certain level. The output will only be triggered when the threshold of the modulation in the pattern is exceeded. This can be set per voice or aligned to a track in multi track mode.

GATE 1 - SEQ 1			
Type	Src	Trhld	-
Thrsh	Lfo 1	64	-
-	-	-	-
-	-	-	-

Threshold selected as type and associated parameter options. Turn (Type) Knob 1 to select the option.

**Threshold Trigger**

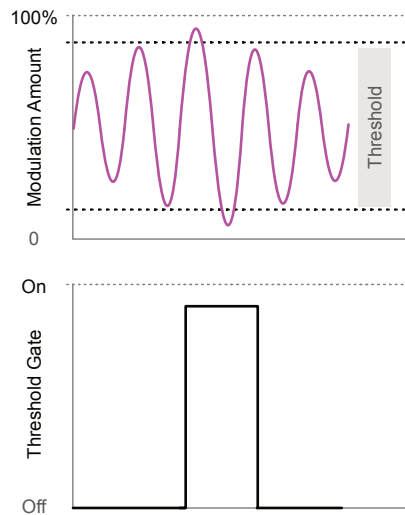

The threshold function monitors a selected LFO or Mod lane amount in a sequencer. The track or voice can be assigned for monitoring.

When an LFO or Mod amount in the sequencer exceeds the threshold a gate is triggered. The trigger will stay high until the value falls below the threshold and then it will reset.

Threshold Settings			
Type	Src	Trhld	
Thrsh	Modulation Source	Threshold	
Sets the output to operate as a trigger. Typically used for notes.	Selects an LFO or Mod lane as the modulation source to monitor the amount.	Sets the threshold amount for the modulation check. When exceeded the gate will be triggered.	

## 9 Connectivity

### 9.4 Analog Drum Application

This example application demonstrates a single voice using individual gate outputs. A simple example is to illustrate gate outputs to control a drum module. OXI ONE is coupled with a Eurorack drum module, Trinity from Modbap Modular.

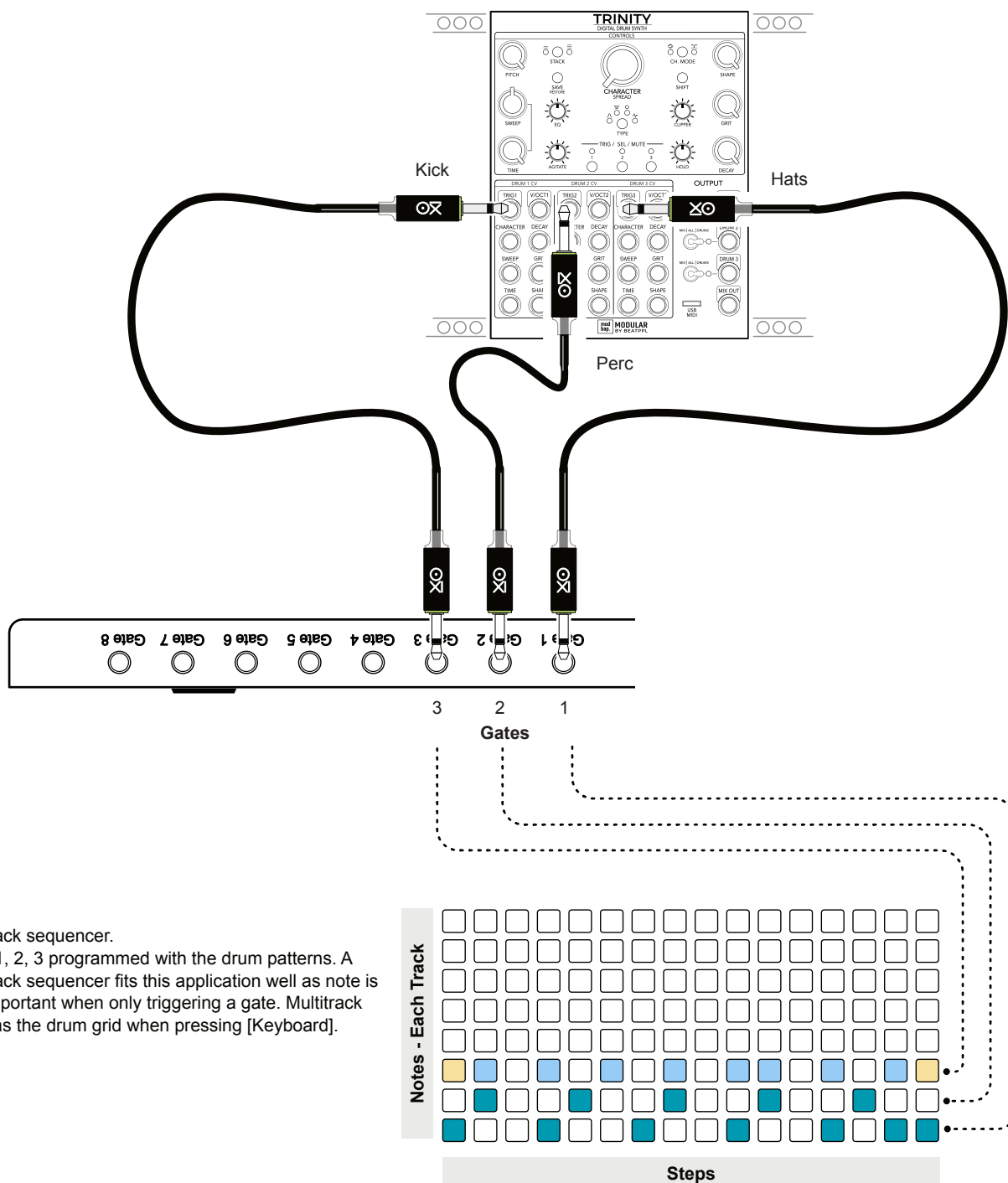

Multitrack sequencer.

Track 1, 2, 3 programmed with the drum patterns. A multitrack sequencer fits this application well as note is less important when only triggering a gate. Multitrack also has the drum grid when pressing [Keyboard].

### 9.5 Analog Synth Voice

This example application demonstrates a mono synth voice application using a CV and gate output. A simple example is to illustrate gate outputs to control OXI Coral in a Eurorack setup. If a polyphonic voice is required, multiple CVs can be configured and one gate based on the rack setup to control. Coral has the unique ability to play polyphonically from one CV based on note values so one CV & Gate works well with Coral. Multiple oscillators or modules may be needed when using other setups for polyphonic voices. This example can be followed for mono setups (or Poly with Coral).

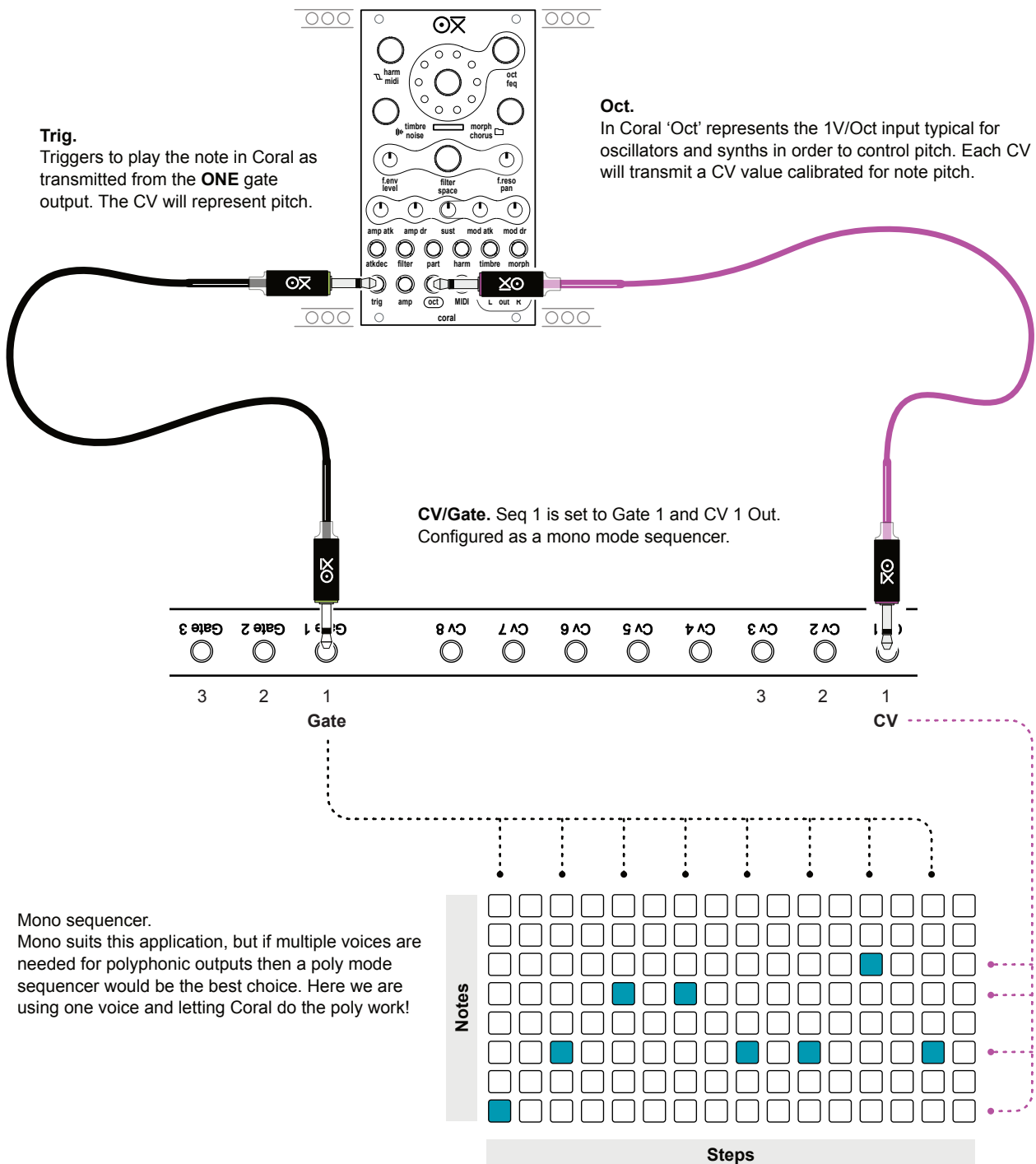

## 9.6 Analog Clock I/O

OXI ONE has both a clock input, for synchronising ONE to external gear, and a clock output where ONE can be the primary clock lead for other external gear. These I/O options follow the classic analog clock models, but ONE can also operate by using a MIDI clock. Clk In is also available from CV Input 2 which is used as a Reset / Stop-Start input by using a TRS to TR-TR splitter and can be routed using the mod matrix. It is important to ensure that the CV In 2 is not used for modulation if it is used for synchronisation. The clock timing in PPQN can be set in the config > analog settings. This must be matched up between devices.

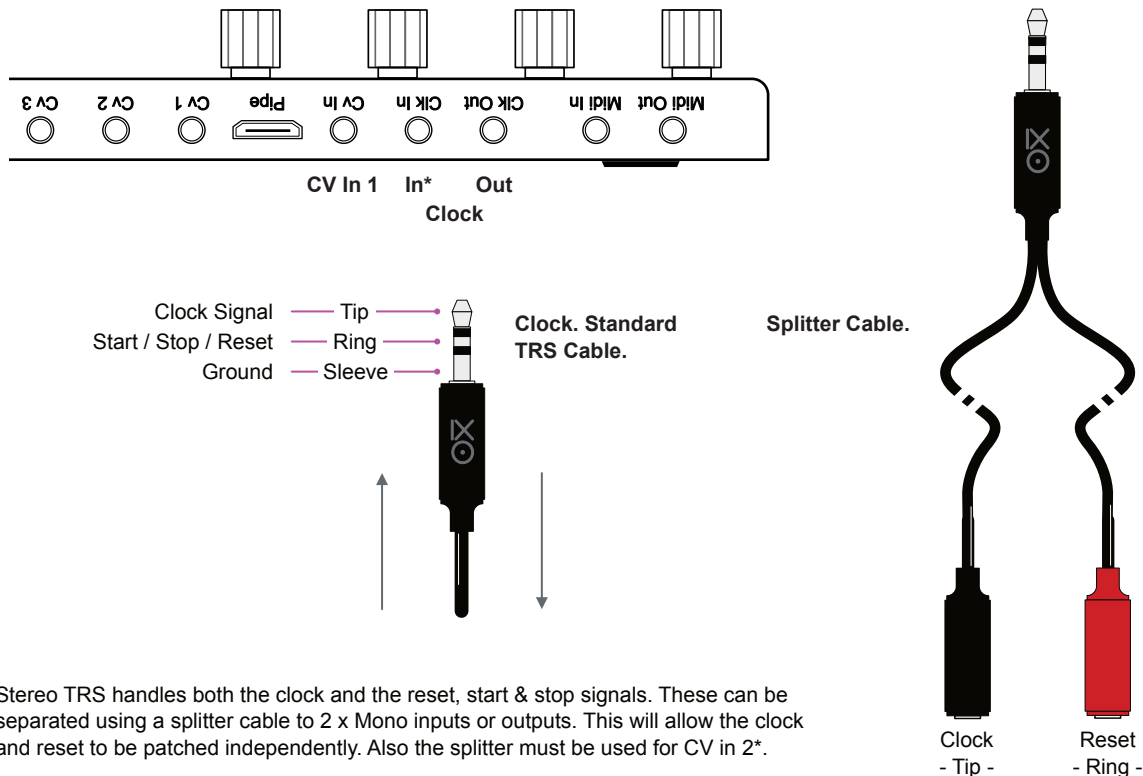

Stereo TRS handles both the clock and the reset, start & stop signals. These can be separated using a splitter cable to 2 x Mono inputs or outputs. This will allow the clock and reset to be patched independently. Also the splitter must be used for CV in 2\*.

### Clock Start / Stop / Reset

The behavior of the clock input and output can be configured in the config > Analog > Reset / Start - Stop (IN & OUT) Settings. Ensure this setting for is 'OFF' if using the Clk input, CV In 2 for modulation\*.

Config > Analog setting	Input	Output
Off	Reset is ignored. With OXI ONE 'Sync' set to Clk, the sequencer will start as soon as a clock signal is received. Does not use Start/Stop/Reset, typically mono TR patch cabled.	Reset signals deactivated. With OXI ONE 'Sync' set to Clk, the sequencer will start as soon as a clock signal is received. Does not use Start/Stop/Reset, typically mono TR patch cabled.
Pulse Reset	Input behaves as a reset signal. When OXI ONE 'Sync' is set to Clk and a reset pulse is received at the reset input, ONE will reset. Seq playheads are reset.	Output behaves as a reset signal. Short 4ms pulse is sent out as the reset signal just before the first clock signal when ONE starts or continues playing.
Run - Stop	When OXI ONE 'Sync' is set to Clk, ONE will only play is run-stop or start-stop is high. Otherwise, of low the sequencer is stopped. Some synths and gear expect this alternate reset operating model.	Run-stop or start-stop output signal is high when the sequencers are playing and low when stopped. Some synths and gear expect this alternate reset operating model.

### 9.7 OXI Pipe MKII Connections

OXI Pipe MKII is a Eurorack module which works exclusively with ONE MKII. Pipe replicates all 8 CV and Gate outputs from those on the rear of ONE onto the Pipe module front panel. Pipe connects to ONE using a supplied, single mini HDMI to standard HDMI cable. Pipe also splits the clock and reset inputs making these also available as individual inputs. Pipe can also be used to link two racks using a full size 2.0 HDMI or 4K cable.

Pipe is 6HP size modules and is a passive device, needing no power.

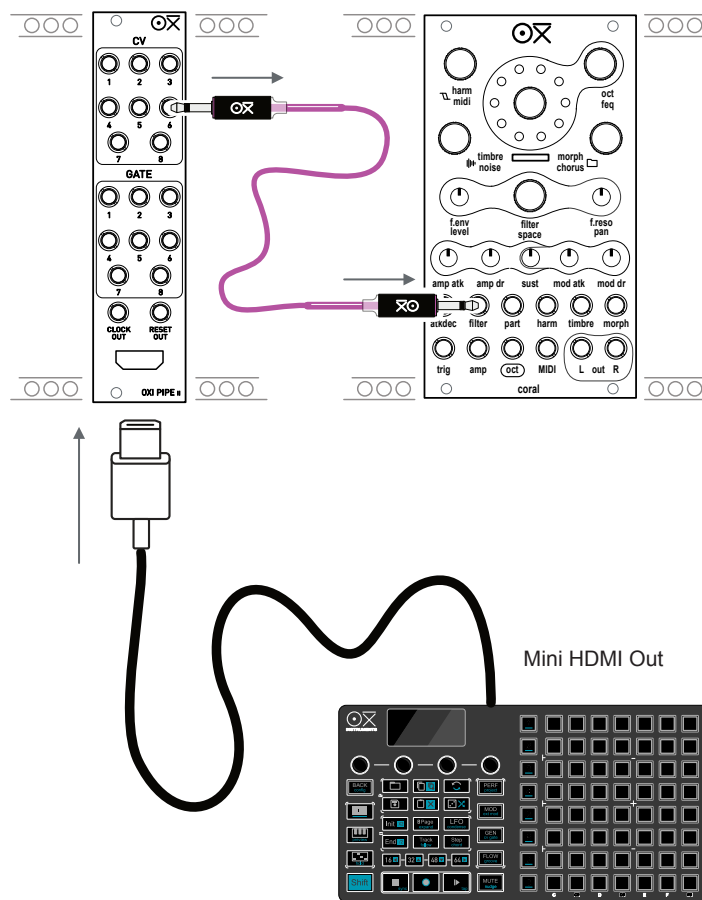

– Note

It is recommended to keep the HDMI cable between ONE and the Pipe module or between two Pipe modules as short as possible in order to retain a high quality and reliable communication link. Also ensure the cable is 2.0 standard. Pipe is not compatible with other Eurorack devices or modules and is exclusively used with ONE.

## 9 Connectivity

### 9.8 MIDI Connectivity

OXI ONE can be used to control MIDI devices, both through note messages and by using CC and PC messages. MIDI can be connected using 3 methods. Firstly by using a TRS MIDI connection in and out. This can also connect to the classic MIDI 5 Pin Din style connections with a type 'A' adapter. Secondly MIDI over USB using the type C connector is possible. Finally, MIDI over bluetooth low energy, also called BLE, is possible for wireless communications.

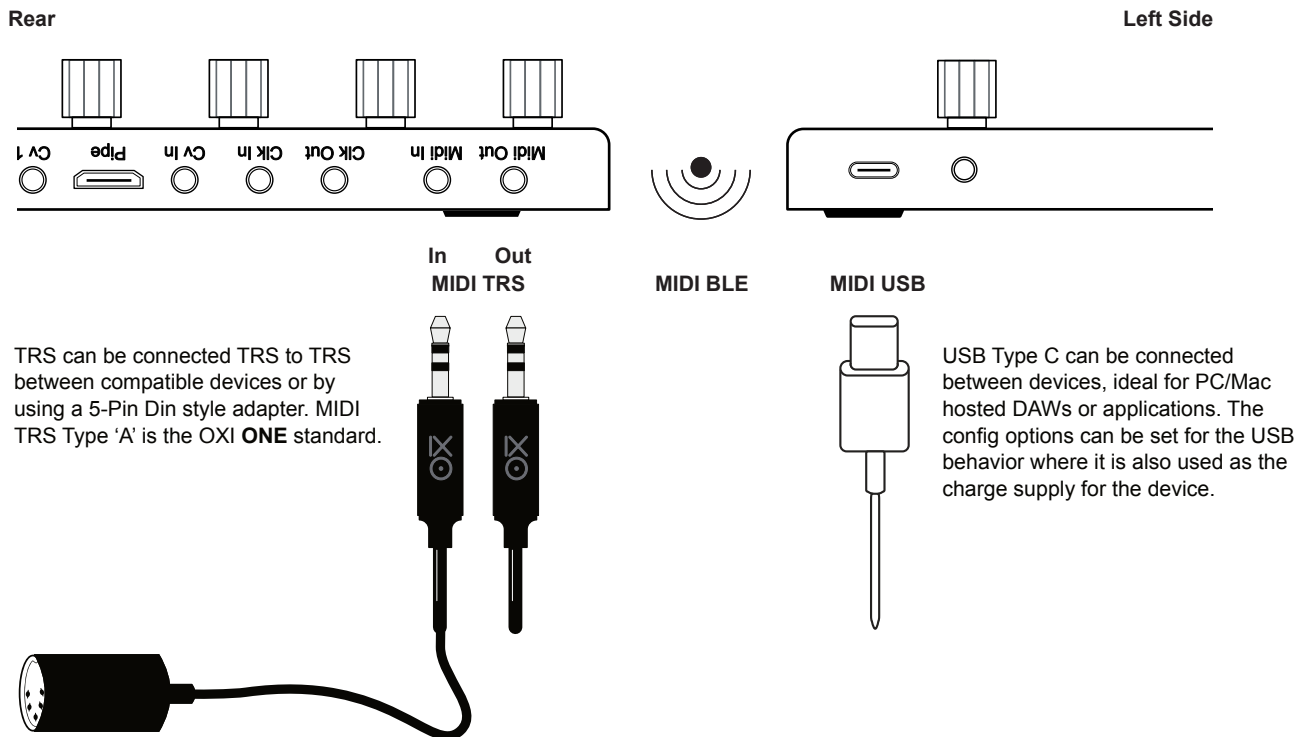

#### MIDI In / Out / Thru

MIDI Thru can be set in the config > MIDI settings for TRS, USB or BLE. If set to On, MIDI messages from this input will be echoed to the other MIDI outputs. If set to off MIDI will not be automatically be passed through the device to an output.

## MIDI USB

When working with USB MIDI the system setting 'USB Mode' must be set appropriately for the application. The most common option is device mode but others are also available.

On the OXI ONE, USB Mode settings: Config > System > USB Mode.

**Device:** OXI Acts as a USB MIDI Device, taking power through the USB interface.

**Host + Power:** OXI Acts as a USB MIDI Host, supplying power through the USB interface to other devices. This may affect OXI ONE battery charge life due to the additional power consumption. Some devices supported include: Roli Seaboard, Arturia Keystep, Akai LPK25 & MPD218, Korg NanoKONTROL2, ASM Hydrasynth, OXI ONE, Miditech Minicontrol32, TE TX-6, TE OP-1 Field, Roland MC101 & MC707, Moog One, 16 & 5, Waldorf Streichfett & Blofeld, Novation 25 SL MkII, Launch Control XL, Launchpad Pro Mk3 & S, QuNexus, Conductive Labs NDLR, Elektron Syntakt.

**Host No Power:** OXI Acts as a USB MIDI Host, but without supplying power to other devices. Some USB adapters require this configuration to operate.

Device mode normally acts like a peripheral device where another item governs and controls the MIDI activity. Think of a device like a keyboard or mouse taking their lead from a PC which acts as the host. A host is the primary MIDI control where MIDI messages are interpreted and governs any other connected MIDI devices.

### Example: MIDI USB OXI ONE to Mac / PC DAW

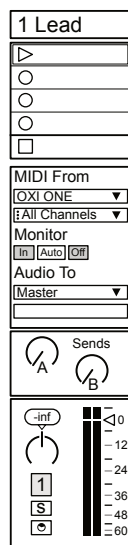
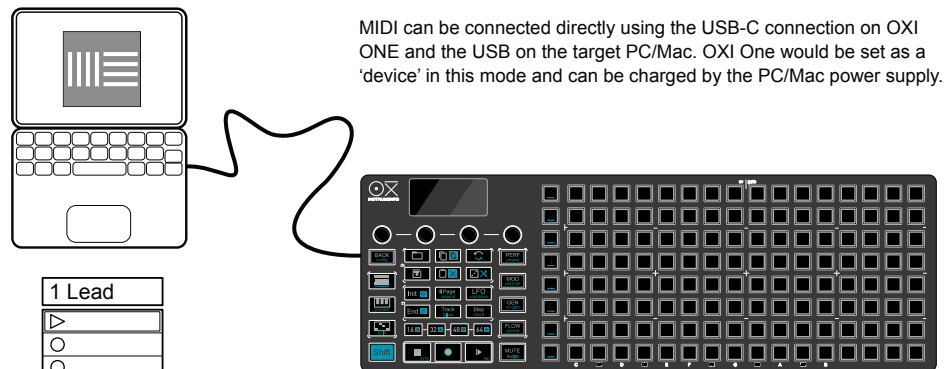

MIDI input can be selected in the PC/Mac DAW to control the virtual instruments and plug ins.

### USB Performance Solutions

USB can be used to charge / power as well as carry digital data in and out of the devices. It is essential to use a compatible cable for MIDI. Some USB cables are designed for power only and can be problematic. Ensure the cable is fully data compliant. A few other tips are provided which may help improve performance or overcome issues with USB communications.

### OXI ONE in Device Mode

Use a [USB Isolator](#) with external supply input to avoid supply/ground loop noises. The isolator requires an external power source, such as a wall charger. Without this, the power supplied to the OXI One will be insufficient, resulting in a gradual depletion of its charge. An example can be [found here](#).

Alternatively to avoid grounding noise you can set the OXI One in "[Device Self Powered](#)" mode. This may not work with some hosts.

### OXI ONE in Host Mode

Tested setups:

- Some devices like the Roli Seaboard work with a USB C to C cable. No need for any adaptor.
- A simple USB C to A adaptor is another great solution to use the OXI One as a USB Host and power supply. The OXI One has to be set in "Host + Power" in this case. Note the power and battery limitations in this case when connecting "hungry" devices. Examples can be [found here](#).
- USB C Power splitter. Use this kind of adaptor when you want to power the OXI One and have a USB MIDI device connected at the same time. The OXI One should be set to "[Host No Power](#)". The USB C male port should be connected to the OXI One which is the Host, the MIDI device should be connected to the USB A female plug (it can be a USB C in some splitters and should be identified with a "data" (instead of power) symbol) and the USB C female plug is the power input.

Here are some examples for this kind of adaptor.

[BCLink](#)

[Ruxely](#)

[Moswag](#)

[Mogood](#)

## MIDI Bluetooth

OXI ONE uses BLE MIDI or Bluetooth Low Energy for wireless communications. BLE can be sometimes technically challenging to set up on some devices so it is advised to use a MIDI dongle such as WIDI Master, WIDI Jack or WIDI uHost when using devices like iPads. Android can be more robust for MIDI BLE.

OXI **ONE** is a dual role device and can operate with BLE as:-

- **Central Role.** OXI ONE acts as a central hub for bluetooth MIDI when connecting peripherals such as keyboards (e.g. ROLI Seaboard, CME Xkey Air etc), BLE Dongles (e.g. CME WIDI BUD), BLE MIDI adapters (e.g. WIDI Jack), controllers (e.g. Korg Nanokey, Akai LPD8) or devices like the Teenage Engineering OP-Z. ONE will automatically look for a peripheral device to pair with directly. Only one device connection is supported.
- **Peripheral Role.** Connects to a central device such as an iOS or Android device, PC, Mac, and devices like CME WIDI Master.

Ensure the external device has bluetooth turned on in order to pair. The pairing process will be determined by the device itself and may be different between devices.

On the OXI ONE, turn Bluetooth on in: Config > System > Bluetooth On/Off.

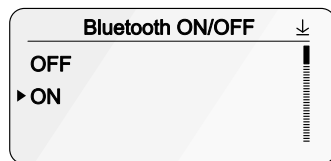

Once the option is selected, tap knob to confirm section and make the bluetooth connection active or inactive.

**Example:** MIDI Bluetooth OXI ONE to iPad AUM App.

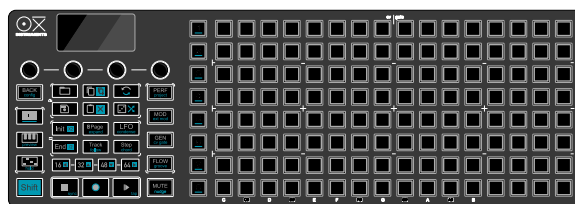

Config > System > Bluetooth On/Off = ON



In AUM: Wireless MIDI Bluetooth Central = OXI ONE MKII BLE iPad is the peripheral device

In the AUM MIDI Routing matrix connect between OXI ONE BLE and the loaded device in the track

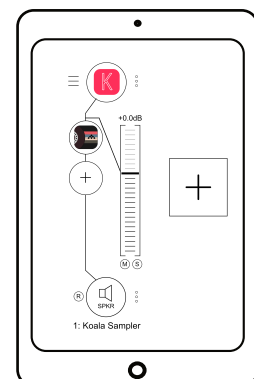

## 9 Connectivity

### 9.9 MIDI Ports & Channels

OXI ONE has the ability to interface with multiple MIDI ports, each with 16 MIDI channels. Port A and B are the default port integral to the ONE device. These may be identified as 1 and 2 on some external DAWs and devices. The 16 channels in ONE are assigned per sequencer, using the [Shift] + Seq [1] - [8] settings menu. The first page allows channels to be assigned by sequencer or by track for a multitrack sequencer.

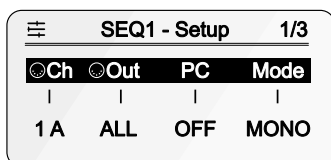
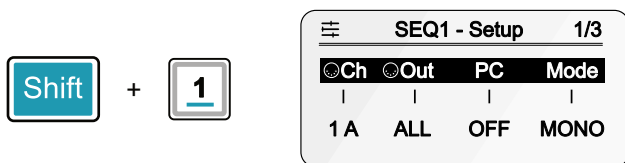

The MIDI Channel is set per sequencer or per track. Options are 1-16, for each port A, B etc. Turn (Type) Knob 1 to select the option.

#### OXI Split 2

The ports can be expanded from the defaults by using OXI Split. This is a low cost option that increases the channel count to 96 by expanding the ports. Split is designed exclusively for expanding OXI ONE and is not generically compatible with other MIDI devices. Incoming MIDI to ONE can be passed thru to the other MIDI output channels using split.

In order to work, set OXI Split II must be configured in: Config > MIDI > OXI Split selection. This can be selected to the original OXI Split V1 which had 3 outs or to OXI Split V2 with 6 outs. This choice will depend on the OXI Split version connected. If Split is removed, the setting must be restored to 'OFF' to use the standard MIDI ports.

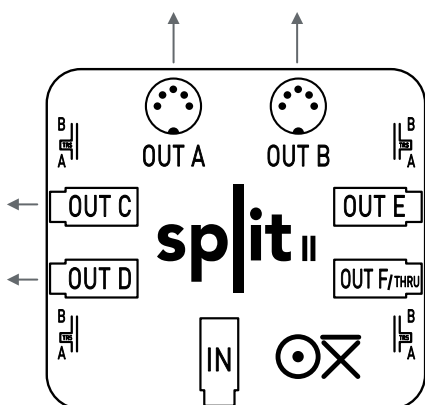

OXI Split is connected using a TRS cable between ONE MIDI Out and Split In port.

Other devices can then be connected using the 2 x 5-Pin DIN style outputs or the 4 x TRS MIDI Outputs. MIDI out or thru is selectable in ONE while the TRS type A or B is selectable on the split device for each of the TRS outputs.

Each output has 16 channels.

- Port A - Channels 1-16 A / 1
- Port B - Channels 1-16 B / 2
- Port C - Channels 1-16 C / 3
- Port D - Channels 1-16 D / 4
- Port E - Channels 1-16 E / 5
- Port F - Channels 1-16 F / 6 - Thru

Important: Cable length for Split 2 should be a maximum of 40cm.

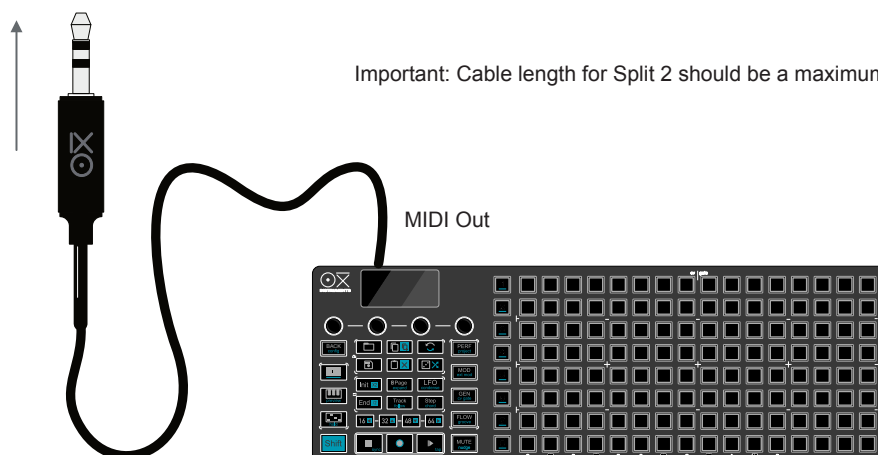

## 9.10 Synchronization

Synchronization refers to the alignment of transport control and especially the clock timing between devices. The assignment of a device as a master clock would set the tempo as a primary lead for other secondary devices to follow.

The default on start up is for sequencer 1 to be selected and the OXI ONE synchronization set to 'Internal'. This can be changed depending on the application and setup required.

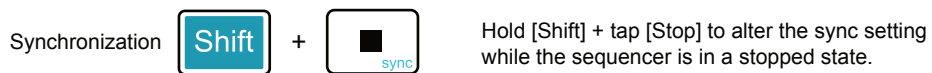

MIDI clock timing is sent and recognised as 24 ppqn - pulses per quarter note in OXI ONE. This is standard for MIDI Clocks and will synchronize easily with most MIDI devices. Analog clock timing can be adjusted in the OXI ONE config menu.

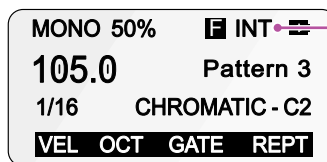

The synchronization option is displayed in the page header. Example shows internal sync.

### Sync Options

Using [Shift] + [Stop] while the sequencer is stopped, the following sync options are available:-

- **INT.** OXI ONE uses its own internal clock. ONE can act as a primary lead in this situation, sending its clock for other devices to follow and the Tempo BPM is controlled in ONE.
- **USB.** OXI ONE uses an external clock, but only the clock received on the USB MIDI port. ONE can act as a secondary follower in this situation, following the clock from another device. Tempo BPM is controlled externally and cannot be adjusted in ONE.
- **MIDI.** OXI ONE uses an external clock, but only the clock received on the TRS MIDI input port or by MIDI Bluetooth. ONE can act as a secondary follower in this situation, following the clock from another device. Tempo BPM is controlled externally and cannot be adjusted in ONE.
- **CLK.** OXI ONE uses an external clock, but only the clock received on the analog CLK input port. ONE can act as a secondary follower in this situation, following the clock from another device. Tempo BPM is controlled externally and cannot be adjusted in ONE.
- **BLE.** OXI ONE uses an external clock, but only the clock received on the bluetooth input port. ONE can act as a secondary follower in this situation, following the clock from another device. Tempo BPM is controlled externally and cannot be adjusted in ONE. Ensure bluetooth is enabled in the system settings. The bluetooth ⌘ symbol is displayed on ONE when connected.

### Latency & DAWs

Latency is the delay which can occur when communicating between connected devices. This is not normally a noticeable issue with hardware devices but with PC/Mac based DAW's it can be a problem. For this reason most DAWs have a compensation option for clocks. If ONE or the DAW acts as a master clock it is worth checking latency and adjusting the delay compensation. In Ableton Live this is called 'MIDI Clock Sync Delay' and is found in the DAW's MIDI settings.

### Auto Sync

Auto sync allows ONE to respond to incoming transport messages. Auto sync is set in the config > performance menu and options are:-

- **ON.** Auto sync is enabled. When ONE is stopped it will respond to a MIDI Start message received from an external device by automatically playing. This applies to incoming messages via the MIDI TRS, MIDI USB, or MIDI Bluetooth. The Analog clk input can also trigger a start. The external clock will control tempo.
- **OFF.** Auto sync is disabled. ONE will not respond to any incoming transport start message.

### Internal Clock Fallback

If a MIDI stop message is received or the external synchronization source is lost, ONE will revert to internal synchronization. This only applies to the MIDI clock and not to the analog clk input.

---

— Note —

OXI ONE has two analog clock ports, one input and one output. Typically these are used with modular gear. The behavior of these is controlled with the Start-Stop/Reset options found in the config menu.



---

### 9.11 MIDI Input Monitor

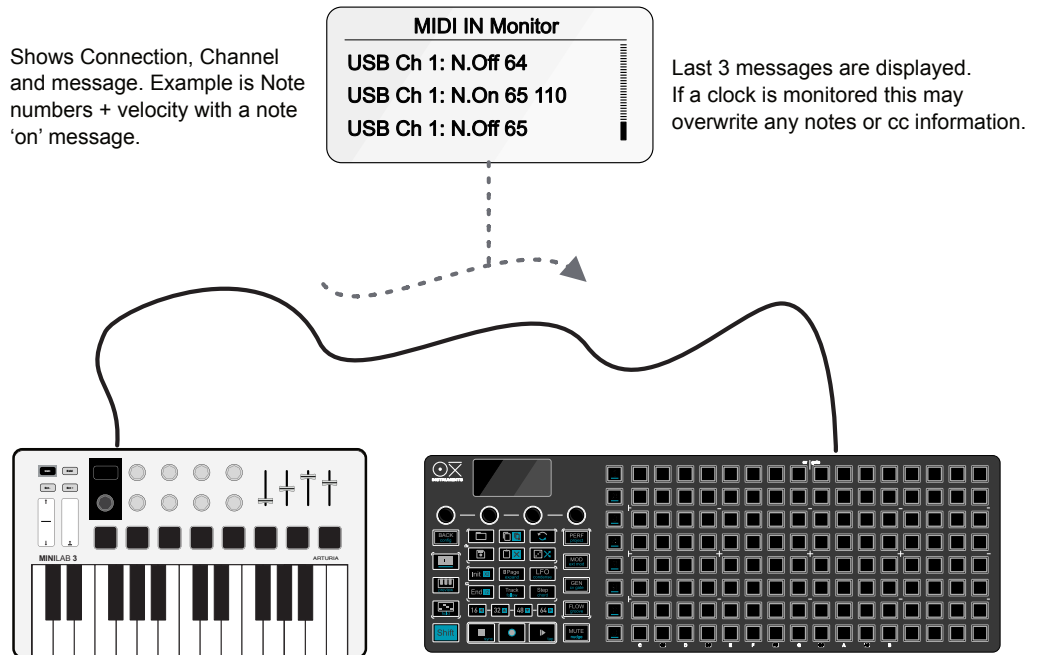
MIDI Monitor is a utility used for checking incoming MIDI activity within OXI ONE from all routes and channels. It is a simple, yet highly useful tool available when needed from the config menu or directly on the user panel.



Turn MIDI Monitor on in: Config > System > MIDI IN Monitor.

MIDI IN Monitor  +  Hold [Shift] + hold [Back] > 2 seconds to open the MIDI Monitor. Alternatively it can be accessed in the config menu.

## 9.12 Instrument Definitions

An instrument definition is a predefined configuration for MIDI CC mapping to external devices. Instead of manually setting up each CC to control an external device parameter, the instrument definition for that selected equipment will map the parameters automatically and apply their names. This saves time and is an efficient way to work with MIDI continuous control messages for external gear.

OXI ONE Instrument definition is selected in the sequencer settings. This examples show Audiothingsies MicroMonsta2 connected by MIDI and CC control can be performed from ONE without manual configuration.

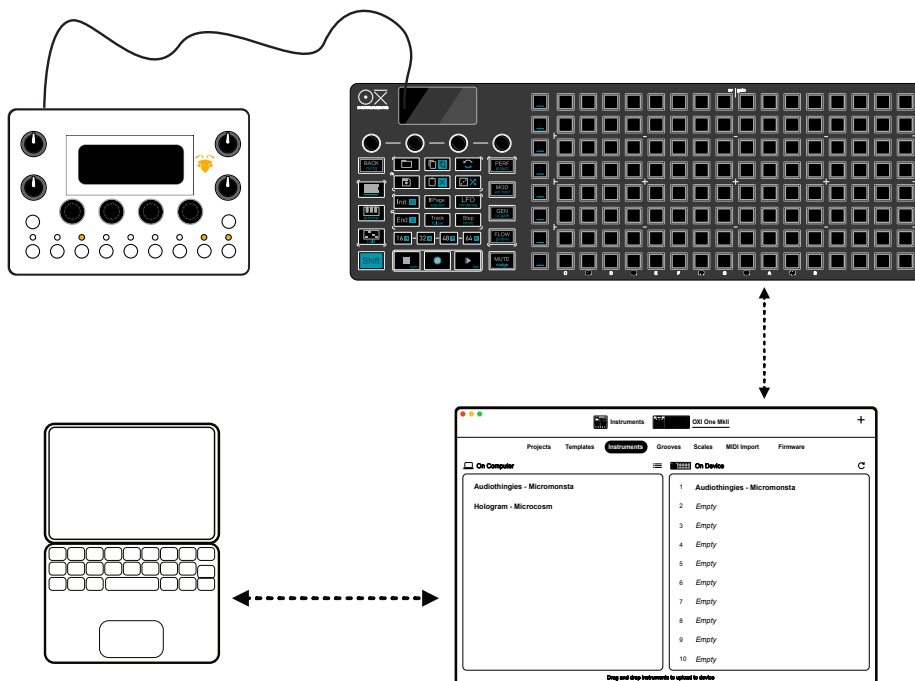

The OXI App can be used to transfer instrument definition files between OXI ONE and a PC/Mac.

The instrument definition for a device is selected in the main sequencer settings, page 3, parameter 'Instr' for the sequencer.

SEQ1 - Setup 3/3			
-	-	Instr	Color
-	-	AdMc	79

— Note —

Instrument definitions are not user configurable on the device but can be created in the OXI App. These can be created individually and then loaded to OXI ONE using the app. If the manufacturer changes the CC mapping of the device the instrument definition may not work as originally configured. Instrument definitions are saved with the pattern and can be backed up with the app.

### Instrument Definitions

The currently available instrument definitions to download via the App are listed. The list captures most definitions available but is always likely to change at any time :-

Manufacturer	Device
ASM	Hydrasynth
Abildgaard	Droid-3
Access	Virus A
Access	Virus T1
Arturia	Microfreak
Arturia	Minifreak
Arturia	Polybrute
Audiothingies	Doctor A
Audiothingies	Micromonsta
Behringer	Deepmind 12
Behringer	Neutron
Behringer	Pro 800
Behringer	TD-3-MO
Black Corporation	Deckard's Dream
Black Corporation	Deckard's Dream Mk2
Conductive Labs	NDLR
Dave Smith Instruments	Evolver
Dave Smith Instruments	OB-6
Dave Smith Instruments	Prophet '08
Dave Smith Instruments	Prophet 12
Dave Smith Instruments	Prophet Rev 2
Dave Smith Instruments	Prophet X (XL)
Dreadbox	Nymphes
Dreadbox	Typhon
Elektron	Analog 4 MKII
Elektron	Analog Heat
Elektron	Analog Heat +FX
Elektron	Analog Rtm MKII
Elektron	Digitakt
Elektron	Digitakt II
Elektron	Digitone
Elektron	MachineDrum
Elektron	Model Cycles
Elektron	MonoMachine
Elektron	Octatrack
Elektron	Syntakt
Elektron	Model Samples
Empress	Echosystem
Empress	Reverb
Ensoniq	ASR-X Pro
Erica Synths	LXR-02
Expert Sleepers	FH-2
Flame	Curve
Flame	Maander
Fred's Lab	Buzzy!
GEM	rp-x
GSmusic	E7
Gotharman	Spazedrum Black

Manufacturer	Device
Hologram	Microcosm
IK Multimedia	Uno Synth Pro X
IK Multimedia	Uno Drum
IK Multimedia	Uno Synth
Intellijel	uMidi
Jomox	Airbase 99
Korg	Arp 2600 M
Korg	Electribe ER-1
Korg	MS2000
Korg	NTS-1
Korg	Opsix
Korg	Wavestate
Korg	Minilogue
Korg	Minilogue XD
Korg	Monologue
Korg	Volca Bass
Korg	Volca Beats
Korg	Volca Drum
Korg	Volca FM
Korg	Volca Keys
Korg	Volca Kick
Korg	Volca Nubass
Korg	Volca Sample
Korg	Prologue
Kodamo	Essence FM
Kurzweil	K2661
LPZW	Tram 8
MFB	Synth II
MFB	Tanzbar 1
MFB	TanzbarLite
MFB	Tanzmous
Make Noise	O-Coast
MeeBlip	Geode
MeeBlip	Triode
Melbourne Instruments	Nina
Meris	LVX
Meris	Ottobit Jr
Meris	Polymoon
Modal Electronics	ARGON8M
Modal Electronics	COBALT5S
Modal Electronics	CRAFTsynth2
Modal Electronics	Craft
Modal Electronics	Skulpt
Modor	NF-1
Moog	Grandmother
Moog	Matriarch
Moog	Minitaur
Moog	Mother 32

## 9 Connectivity

Manufacturer	Device
Moog	Sirin
Moog	Sub-Phatty
Moog	Subsequent 25
Moog	Subsequent 37
Moog	Voyager
Mutable Instruments	Shruthi
Norand	Mono
Nord	Drum 2
Nord	Drum 3P
Nord	Lead (Rack)
Nord	Lead (Rack) 2x
Nord	Wave 2
Novation	Bass Station II
Novation	Bass Station Rack
Novation	Circuit
Novation	Nova
Novation	Summit
Novation	Peak
OTO Machines FX	BAM
OTO Machines FX	BIM
OTO Machines FX	BOUM
OXI Instruments	Coral
Oberheim	OB-6
Oberheim	OB-X8
Pioneer	Toraiz AS-1
Polyend	Tracker
Red Panda	Particle
Red Panda	Raster
Roland	D-05
Roland	GAIA SH-01
Roland	JD-XA
Roland	JD-XI
Roland	JP-08
Roland	JU-06
Roland	JU-06A
Roland	JV1010
Roland	JX-03
Roland	JX-08
Roland	Juno 60 Minerva
Roland	Jupiter X (xM)
Roland	MC-101
Roland	MC-2oh2
Roland	MKS-50
Roland	MX-1
Roland	S-1
Roland	SE-02
Roland	SH-01A
Roland	SH-4d
Roland	System 1 (1M)
Roland	System 8

Manufacturer	Device
Roland	TB-03
Roland	TB-3
Roland	TR-06
Roland	TR-08
Roland	TR-09
Roland	TR-6S
Roland	TR-8
Roland	TR-8S
Roland	VP-03
Roland	XV-5050
Sequential	Pro 3
Sequential	Prophet-6
Sequential	TAKE 5
Sherman	Filterbank
Sonicware	Liven Lofi 12
Sonicware	Liven XFM
Sonicware	Smpltrek
Strymon	Nightsky
Strymon	Volante
Studio Electronics	ATC-1
Studio Electronics	SE-1X
Studiologic	Sledge
TC Electronic	D-Two
Tasty Chips	Gr-1
Teenage Engineering	OP-1
Teenage Engineering	OP-Z
Twisted Electronics	MEGAfm
Twisted Electronics	TherapSID
UDO Audio	Super 6
Waldorf	Blofeld
Waldorf	Iridium
Waldorf	M
Waldorf	Pulse 2
Waldorf	Rocket
Waldorf	Streichfett
Yamaha	Reface CP
Yamaha	Reface CS
Yamaha	Reface DX
Yamaha	Reface YC





# System

As we draw to the final chapter of the manual supporting OXI ONE MKII, we hope the journey has been interesting, creative, and fun. This section may fit into the housekeeping category and be less interesting when the urge to make music quickly arises. Here, the firmware updates are covered along with the OXI App and a complete overview of the configuration options. There are some useful elements that will be important to know, if not now, then certainly in the future. It is recommended that you at least familiarise yourself with the content and features covered here for future reference and awareness. For people interested in the OXI remote control and scripting information, please visit this [OXI Remote Control Reference](#) link. The shortcut summary for control commands is also included as a reference, useful to print. To finish, OXI Instruments would like to issue a heartfelt and big thank you for buying OXI ONE and following our journey from the original ONE to the ONE MkII and its associated ecosystem of gear. Good luck with your musical adventures; hopefully, OXI ONE will play a part in them. Remember, things don't end here; only the manual does. The real journey is only just starting. Have fun!

## 10.1 OXI App

Most device management activities when working with the OXI gear is handled using the OXI App. This is a stand alone utility that, when connected to an OXI device will help update, backup and transfer data between the device and a PC or Mac. The app can be downloaded from the OXI site.



The OXI ONE App can manage operations between a PC / Mac and ONE:-

- Manage and backup projects.
- Transfer templates between the PC/Mac and ONE.
- Create and transfer grooves between the PC/Mac and ONE.
- Manage instrument CC definition files between devices.
- Transfer scale files between the PC/Mac and ONE.
- Import MIDI files to ONE.
- Check the available firmware in comparison with the OS installed on the connected ONE and perform an update to the firmware on the device.

**Project Backup & Transfer**

Projects can be downloaded from the OXI App and stored in a location assigned in the App. The option to set a storage directory is available which assigned a folder on the PC/Mac as the storage location for ONE files and data

Projects can be downloaded as a full collection or individually by dragging from the device across to the computer within the app. Projects can in addition be copied from ONE to the microSD Card using the options in the 'Project' menu accessed using [Shift] + [Perf].

**Projects Tab**

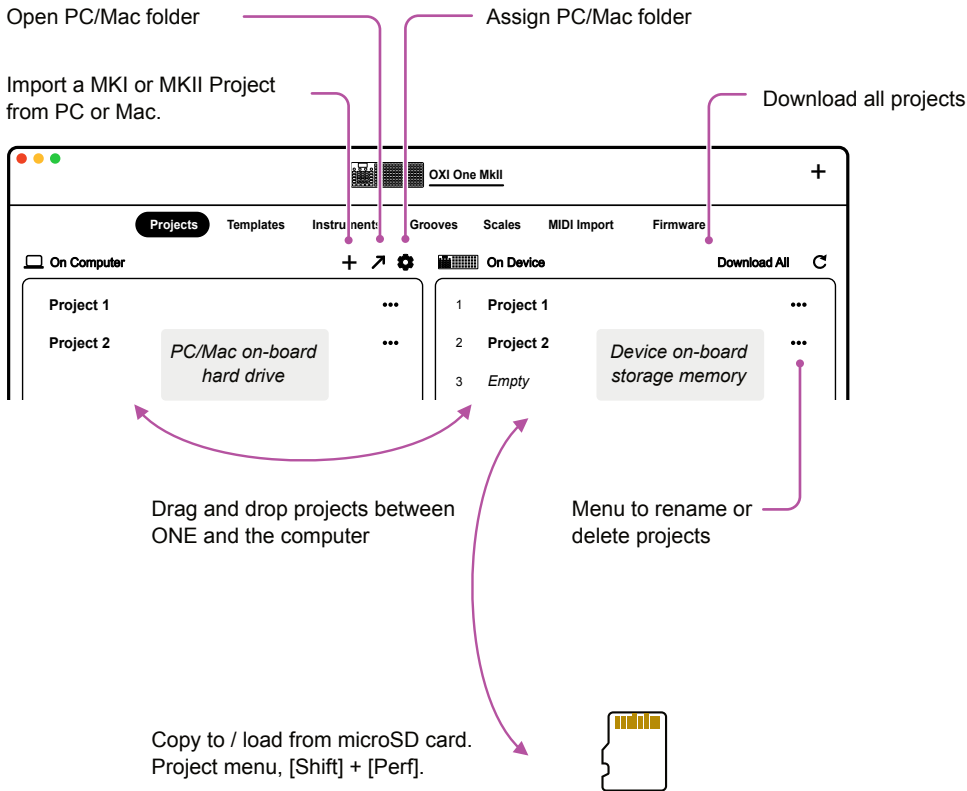

**MIDI Import**

It is possible to import MIDI files into OXI ONE using the App. When importing files they will need to reside on the PC or Mac. An example is a MIDI file exported from Ableton Live: File > Export MIDI Clip and stored ready to import to ONE. The following considerations are important when creating external MIDI files for importing.

- Files can be imported to a mono or poly pattern in ONE. Consider the dynamics and scope of these sequencer when creating external MIDI.
- Patterns will be imported to the currently selected sequencer and pattern in OXI ONE.
- Maximum length is 8 bars.
- Note polyphony. Must have 1 track with maximum note polyphony of 7 notes.

## Grooves, Instruments & Scales

Templates as well as grooves, instruments and scales can also be dragged and dropped in the app. In addition the groove, instrument and scale functions have built in utilities for creating new grooves, user scales and definitions. Look for the 'Pencil' icon to signify access to the editors or '+' to create new from their main pages.

### Groove Editor

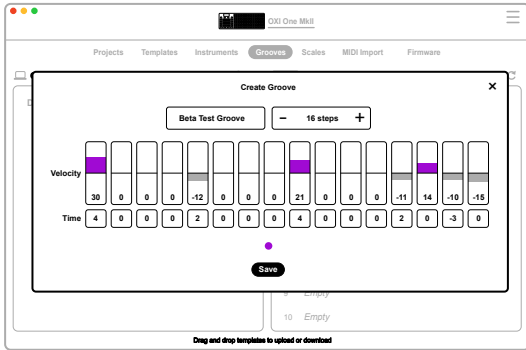

Grooves consist of step variations for velocity and micro-timing. Groove templates can be created in the app, named, transferred to ONE and then used in several groove orientated applications, for example the arp.

### Scale Editor

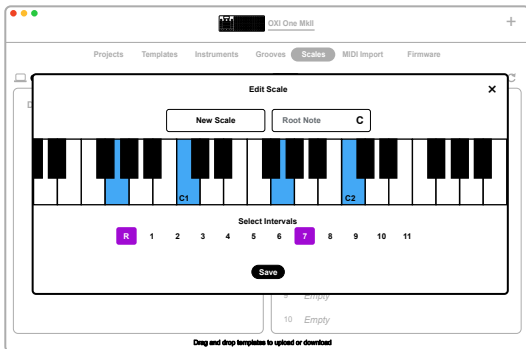

User scales can be created starting with a root note and setting the interval or note selection options. Scales can be created in the app, named, transferred to ONE and then used in several scale applications.

### Instrument Definition Editor

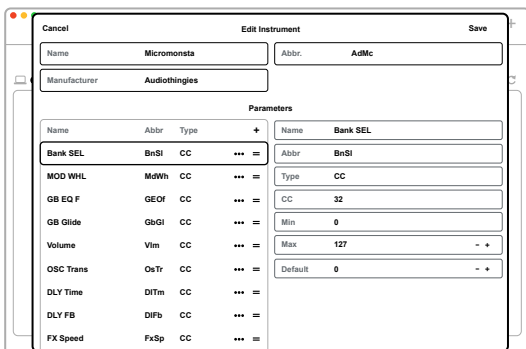

Instrument definitions can be built that act as a preset template for the control configuration of external devices from ONE. The instrument definition editor will help create new definitions, save and load them.

Definitions can also be downloaded and imported from OXI Instruments or MIDI Guide CSV files.

### 10.2 SD Card

The OXI ONE microSD Card socket is located on the left side of the device. Only microSD Cards should be used, inserted with pins facing up. Upon start up ONE will create or check the configuration of the microSD Card folder structure.

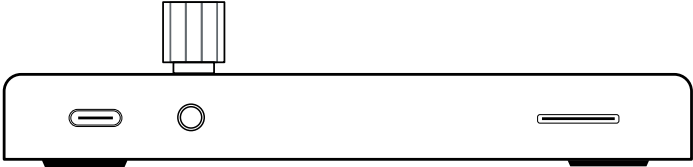

Insert pins facing up. To retract the card push gently in, until the click sound signifies its latch is released.

The microSD should be formatted to FAT32 or exFAT standard.

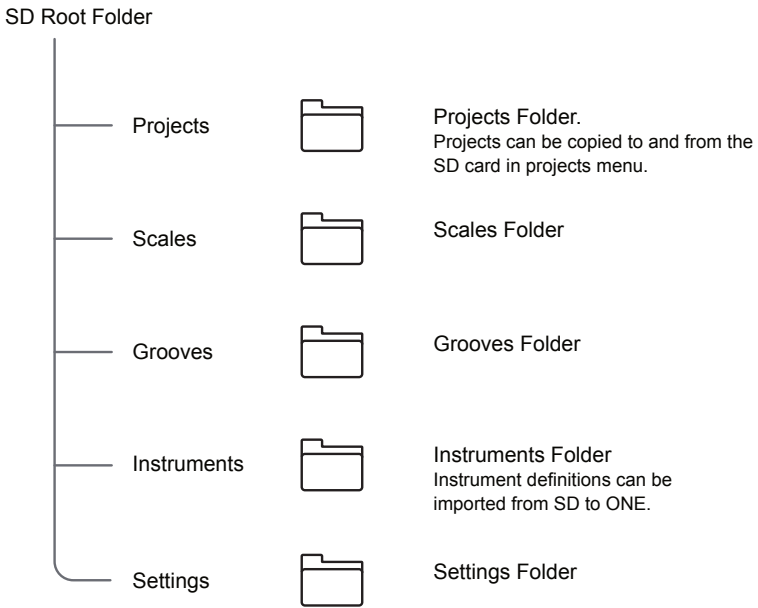

The microSD folder format is setup when powering up OXI ONE. If the folder structure already exists it will be checked and verified during start up.

## 10.3 Firmware Update

Updates to OXI ONE firmware are released from time to time to add new features, improve performance and fix bugs. The update process is automated within the OXI App. Simply connect the PC/Mac to OXI ONE and open the 'Firmware' page. The current status of the device and any available firmware versions will be displayed.

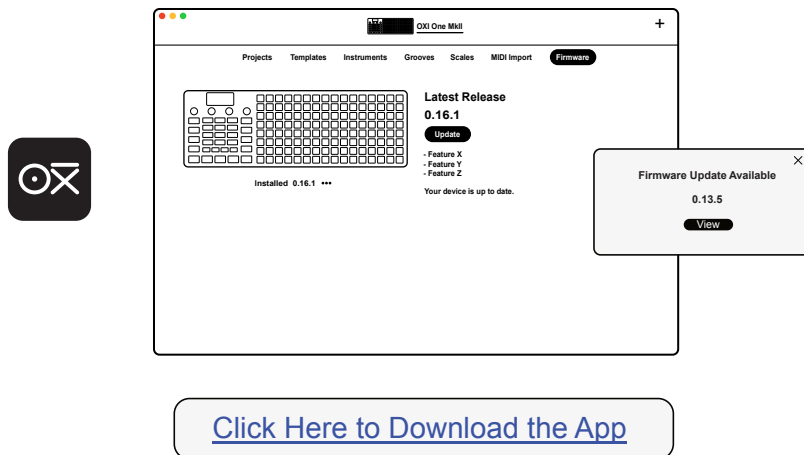

The currently installed firmware version and hardware version can be viewed in the Config > System > FW & HW Option menu.

Manual update from a file is possible. Open the sub-menu by clicking **...**.

### ► Update Firmware

1. Connect OXI ONE to the PC or Mac which hosts the OXI App using the USB connection. Also ensure the PC / Mac is connected to the internet and ONE is in USB device mode, set in the config > system > USB mode settings.
2. Open the OXI App.
3. In the 'Firmware' page the currently installed firmware will be displayed as well as the latest available firmware. It is possible to update from this page.
4. Any newly available updates will be displayed in the pop-up message. Click 'View' to see more information and to proceed to perform the update.
5. While updating the update progress bar will be displayed on ONE. Do not disconnect the devices while updating.
6. Once complete, ONE will reboot. Update takes between 15 - 60 seconds.
7. Note that the option to update a specific firmware version from a update file is also possible. Click the 3 dots under the ONE image and the options to update the firmware or bluetooth driver from a file will be available. The file must have been previously downloaded to a location on the PC/Mac.

## 10.4 Troubleshooting Updates

It is unusual for the OXI ONE to freeze or to get locked into a 'bricked' condition while updating. Should this situation occur the following steps should be followed.

### ► Failed Update

1. Connect OXI ONE to the PC or Mac which hosts the OXI App using the USB connection. Also ensure the PC / Mac is connected to the internet.
2. Push and hold the power button of OXI ONE to force it to off.
3. Power up in update mode. Hold [Mute] while pressing the power on button. ONE should power up in update mode.
4. Try updating again using the App but use a downloaded OS version. This could be an older revision or the latest version.
5. Try powering off / on. Repeat the procedure.

—Note—

The Sysex Librarian utility can be used if the PC/Mac OS doesn't support the App.

## 10.5 Sequencer Interface LEDs & Colors

The grid pad LED colors can be changed for the sequencers. This is changed in in the main sequencer settings, page 3. Also the sequencer button colors can operate as turquoise scheme or colored. This is set in the config > workflow.

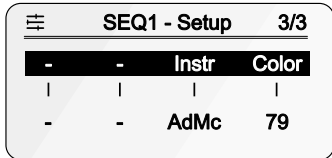

The color setting can be adjusted with knob 4 (color). Colors are defined by a number which can be changed to a recognized color or tweaked to suit personal taste.

### Defined Grid Colors

The table indicates the defined colors for OXI **ONE** scheme. Other values can also be set.

OXI Color	Code Number	
Purple	0	
Blue	10	
Lilac	23	
Violet	30	
Baby Pink	34	
Yellow	39	
Magenta	49	
Pink	61	
Orange	69	
White	77	
Turquoise	79	
Aquamarine	90	
Light Blue	100	

In addition to the colors the following grid interface presentation can also be edited as follows:

LEDs Animations: High, Low, Off.

LEDs Brightness: Low, High, Very High.

LEDs Backlight: OFF, Low, High.

All of these settings are options found in Config > System.

### Sequencer Button Colors

There are two scheme options for the grid buttons, multi-colored when set to 'Yes' or white / turquoise for the default when the setting is 'No'. The option is found in: Config > Workflow > LEDs Colored SEQuencer Buttons. This only affects the 8 sequencer buttons.

**1** Default is the white / turquoise scheme. Option is set to 'No'.

**1** Option is the multi-colored scheme. Option is set to 'Yes'.



### 10.6 Analog Calibration

The OXI One comes factory calibrated when supplied. The calibration has been made using high precision equipment. If for any reason the calibration procedure has to be repeated, please follow these instructions. Make sure to use a good reference like a 5 digit multimeter or a well tuned VCO (with V/Oct CV input) along with a Tuner. Only perform a calibration if it is absolutely necessary.

Enter calibration mode, hold [Shift] + [Gen] for until OXI ONE switches to calibration mode as indicated on the display screen.



The OXI ONE's CV's have a range from -3V to +5V which represent the octaves from note C-1 to C7 in the V/Oct format. The MIDI note 12 represents C-1 in OXI ONE.

#### Calibration Table

The values that OXI ONE should output for each octave are presented in the following table. This applies to each of the eight CV outputs.

Note	Expected Voltage
C-1 (12)	-3V
C-0 (24)	-2V
C 1 (36)	-1V
C 2 (48)	0V
C 3 (60)	1V
C 4 (72)	2V
C 5 (84)	3V
C 6 (96)	4V
C 7 (108)	5V

Every point in the range must be calibrated and checked for each CV.

Follow the process below in order to perform a full calibration. Calibrate every point in the table for every CV output. Note that the note value played on a keyboard will generate a voltage level that represents the note played. Higher notes send a higher CV, It is this voltage level with respect to the note that is being calibrated.

## ► CV Calibration Process

1. Configure the CV outputs to a track in order to play notes that send a CV to the output which is being calibrated. For example a mono sequencer 1 set to CV 1.
2. Set up a measurement device ideally a precise multimeter with 3 decimal places to measure the voltage at the CV output.
3. Every CV listens to a different MIDI channel, CV1 listens to MIDI Channel 1 and CV2, to the MIDI channel 2 and so on, until CV8 in channel 8. You can do it with any keyboard connected to the MIDI IN port, but we recommend doing it in your DAW to better see the octave range. If you are an Ableton user, you can download the project linked below.
4. Calibration mode is selected by holding [Shift] + [Gen] for 2 seconds. Hold until the calibration page appears.
5. Check calibration, play C2. The output voltage should be 0V. Any values above or beyond this, for example if it measures 0.123V, demonstrates an uncalibrated output
6. To adjust it down you should press the immediate key below C2 which is B1. The output voltage would decrease around -0.002V (+2mV).
7. To adjust it up, you should press the immediate key above C2 which is C#2. The output voltage would increase around +0.002V (-2mV).
8. If your meter does not have many decimal places, you will need to press several times until you start to see the voltage change.
9. If you press A#1 (instead of B1) or D2 (instead of C#2) the jump is bigger (20mV instead of 2mV) to speed up the process.
10. Press it repeatedly until the voltage offset is within  $\pm 0.003V$  ( $\pm 3mV$ ) off the expected value.
11. Continue through all points of the calibration curve, then press C8
12. Repeat the process with all the CV outputs.

Ableton Live Calibration Project - [Download Here](#).

## 10.7 System Settings & Config Summary

A collective set of parameters provided here. These are accessed using [Shift] + [Config]. The usage details are explained in the relevant sections of the manual.

When in the config menu, hold [Shift] + [Back] to save the configuration settings.

### MIDI

Option	Topic	Description
OXI Split selection	OXI Split	On sets the MIDI TRS to be compatible with Split and Bluetooth bandwidth.
MIDI Transport Msgs Send	Transport Out	On sends clock, start, stop, continue messages out through TRS, USB and Bluetooth.
Start Stop Msgs Ignore	Transport In	Set to 'Yes' to ignore any incoming start and stop commands. Set to 'No' for external transport control.
MIDI TRS Thru	Thru	On allows incoming TRS MIDI messages to be echoed back out.
MIDI USB Thru	Thru	On allows incoming USB MIDI messages to be echoed back out.
MIDI BLE Thru	Thru	On allows incoming bluetooth MIDI messages to be echoed back out.
MIDI In channel filter	Channel	Sets the behaviour of how the MIDI channel operates. Options are Off, MIDI Channel or Channel & Note.
MIDI In Port (A-F) Merge	OXI Split / Channels	On will replicate data from all MIDI inputs to port A - F, for the same channels.
Keyb Scale note quantize	Quantize	On will quantize incoming notes to the scale set for the receiving sequencer.
Send CC of MULTI muted tracks	Multitrack Mode	Set to 'Yes' to send CC modulation information out even from muted tracks.
MOD default Smooth Factor	Mod Lanes	Smooth amount for the automation values between step columns for the modulation curve. Range 1-30.
CC Transport Msgs transmit channel	Transport Out	Set to off or select the channel 1-16 to send the transport CC start, stop, continue, rec out.
PC (Program Change) receive global channel	Program Change	Sets the channel to allow incoming PC messages to change the sequencer patterns. Can be set to off.

## 10 System

### Analog

Option	Topic	Description
PPQ Out	Analog Out	Configures the pulses per quarter note setting for the analog clock output. 24PPQN, 1PP16, 2PPQ, 1PPQ.
PPQ In	Analog In	Configures the pulses per quarter note setting for the analog clock input. 24PPQN, 1PP16, 2PPQ, 1PPQ.
Reset / Start-Stop (IN & OUT)	Analog Transport	Sets the behavior of the reset / stop-start input and outputs. Off, pulse reset, run-stop options.
Gate V Out	Gate Output Range	Sets the gate voltage output range to either 5V or 10V. Use will depend on the connected gear.
Remember Params when On/Off individual outs	Outputs	Set to 'Yes' to remember the output values when turning an output off / on. Otherwise outputs are reset.
CV & Gate voice allocation	Voicing	Select the voicing mode between LRU - Least Recently Used, LOW and Unison - Play together.
Pitch Bend Range	Pitch bend	Sets the semitone range of the CV pitch bend value.
Gate ALL retrigger	Analog Out	Sets whether the output gates can retrigger on or off.

### Performance

Option	Topic	Description
Play/Pause behavior	Transport	Behavior of the play button while playing. Off - doesn't pause, On - play will pause, Reset seqs play head.
Mute behavior	Mute	Sets the mute button behavior to toggle instantly or on release of the button. Also keeps seq running or not.
Keep Mutes in Multi mode when loading pattern	Mute - Multi track	Set 'Yes' to preserve current mute state when patterns are loaded. Empty patterns always reset mute.
Keyboard Layout	Grid Keyboard	Sets the grid keyboard to be presented in Classic, Isomorphic 5ths or Isomorphic 4ths layout.
Auto Sync	Transport	On enables auto sync meaning ONE will respond to incoming start messages over MIDI or CV.
Taps count for tempo	Tempo	Sets the number of taps to establish a tempo change 2-5. Infinite allows for smoother, visible transition.
Keyb Arp Velocity	Arp	Uses the global velocity value for the arp notes or uses note velocity as played in - per played note.
Latch notes when Keyboard Hold is active (by default)	Arp	Sets the default for the arp shift + keybd hold. On will add new notes and off will only apply new notes.
Arp patt Reset on note change (by default)	Arp	Set to 'Yes' to reset the arp to the start when the arp notes are changed.
Loop Sync release	Loop	The loop when released will either continue from the release point - no sync, from the next beat or bar.
Harmonized seq Octave Max	Harmonizer	Sets the maximum octave range 1,2 or 3 that the follower sequencer can make when harmonized.
Harmonized seq stays in base octave	Harmonizer	Set to 'Yes' for the follower sequencer to ignore octave pitch offsets. All notes play in base octave.
Load Project BPM update during playback	Tempo	Set to 'Yes' to update the BPM from a newly loaded project or otherwise retain existing project BPM.

## Workflow

Option	Optimal Range	Description
Lock root and scale during playback	Playback	Set on to lock the root and scale to prevent changes.
Confirm scale change and quantize notes	Scale Quantize	On to apply scale quantization directly while editing or needs to be confirmed to become active.
Lock sequencer steps with previous ON	Steps	When on, prevents steps being edited when 'preview' is set on, otherwise steps can be edited anytime.
Latch SHIFT with double tap	Shift	When set to 'Yes' the shift button will stay on when double tapped. Otherwise will need to be held.
Track select priority in multitrack	Multi track	When 'On' the first pad tap will select the track, then steps can be set otherwise tapping a pad sets a step.
Reset step parameters when clearing	Steps	Set to 'No' to avoid resetting to default a step when applying new notes or chords. Yes retains existing values. Applies to mono, chord and multitrack modes.
Default Velocity value	Velocity	Default velocity value for notes and keyboard.
Default Gate value	Gate	Default gate value for notes and keyboard arp.
Selected track indicator in Multitrack	Multi track	Set to 'Yes' to display the yellow track selection indicators in multi track mode.
LEDs Colored SEQuencer Buttons	Sequencers	Set to 'Yes' to set the sequencer buttons to a multi-color scheme. No retains the turquoise buttons.
LEDs Transport bar keyboard	Sequencers	Set to 'On' to show the transport playhead in the grid keyboard view. Otherwise the playhead is not shown.
Inverted TIE gesture for Fills or Randomizing	Steps	Sets the behavior of the hold last + first pad command. Off, Fills to add repeats or Randomize to apply random notes between the two pads, same row.
Disable pick and place	Various	Pick and place option can be disabled by setting to off

## System

Option	Topic	Description
MIDI IN Monitor	Utility	Display monitors incoming real-time MIDI messages.
LEDs Animations	Utility	Sets the amount of fade and animation of pads.
LEDs Brightness	Utility	Low, High, Very high Pad LED brightness setting.
LEDs Backlight	Utility	Sets backlight level of command button LEDs.
Screensaver Animation	Utility	Enable or disable the screen saver animation.
Inactivity Power-Off Time	Utility	Sets the device time duration before power off when not in use. 1 hr, 2 hr, 4 hr, 8 hrs, 12hrs.
Bluetooth ON/OFF	Utility	Sets the bluetooth on or off.
Battery charge enabled	Utility	On - charges via USB. Otherwise USB is data only.
USB Mode	Utility	Selects how the USB operates. Device or host options.
FW & HW Version	Utility	Displays hardware, firmware and bluetooth versions.
RESET (All but calibration)	Utility	Resets the OXI ONE to factory settings. Retains calibration settings.

## 10.8 Quick Reference Shortcuts

A selection of key commands is available here. This is a useful resource to keep alongside ONE as a reference and perhaps even print separately and add your own notes to make it even more complete.

Global Commands		
Shortcut	Command	Description
[On/Off]	Power up <b>ONE</b>	Push the left side power on/off button to turn <b>ONE</b> on / off.
[Mute] + [On/Off]	Update mode	Power up <b>ONE</b> in update mode. This is an alternate process for performing a firmware update.
[Shift] + ....	Secondary Command	Access to a secondary command, typically colored options. Access while holding 'shift' and selecting the commands.
[Shift] x 2	Latch shift on	Double tap to latch the shift button on. Needs to be setup first in the config menu.
[Back]	Back up	In menus and functions press 'back' to navigate back.
[Load]	Load a project	Press 'load' then turn knob 1 to browse the projects to load. Press knob to load the highlighted project.
[Save]	Save a project	Press 'save' then turn knob 1 to browse. Press knob to save. The project rename option is also in the save menu.
[Shift] + [Save]	Quick save the project	Saves and overwrites the previously saved project with the current version.
[Shift] + [Load]	Quick reload the pattern	Reload and overwrite the current pattern with the previously saved version.
[Load]	Load menu	Knob 1 navigates projects and knob 2 patterns. Grid represents pattern slots 1-16 per sequencer.
[Save]	Save menu	Knob 1 navigates projects and knob 2 patterns. Grid represents pattern slots 1-16 per sequencer.
[Copy] + [Pad]	Copy Pattern	In the load or save menu. Copies a pattern from the slot represented by the selected pad.
[Paste] + [Pad]	Paste Pattern	In the load or save menu. Pastes a pattern to a slot represented by the selected pad. Project is updated.
[Mute] x 2	Latch mute on	Double tap to latch the mute button on. Useful when working with multiple mute orientated options.
[Shift] + [Keyboard]	Audio preview	Auditions the audio on the external device while playing notes in sequencer view.
[Page]	Change page	The page button will flash when multiple pages exist. Tapping the button will navigate through, selecting the next page.
[Load] + [Save]	Capture Snapshot	Temporarily saves the sequencer settings and state. Allows edits and performance ad libs to be reset.
[Load] or [Undo]	Release Snapshot	Restores original state, pre snapshot.
[Load] + [Save]	Cancel a snapshot	Cancels and clears an active snapshot. Also can be cancelled with [Shift] + [Undo].
[Shift] + [Back]	MIDI Monitor	Opens the MIDI input monitoring utility. Displays last 3 incoming MIDI messages.

Generic Sequencer Commands		
Shortcut	Command	Description
[Play]	Play sequencers	Start playing all sequencers from step 1. Button flashes green to indicate play is active.
[Stop]	Stop sequencers.	Stop playing the sequencers and reset the playhead to the first step.
[Rec]	Arm recording	Select recording. Sets the sequencer ready to start recording once [Play] is pressed.
[Rec] + [Stop]	Arm recording	Arm recording. Will recording start when a note from the keyboard or MIDI input is received.

Generic Sequencer Commands - continued		
Shortcut	Command	Description
[Rec] + [Play]	Step recording	Selects step recording. SH101 style step by step sequencing of notes.
[Shift] + [Play]	Tap tempo	Tap the tempo beats per minute value. Number of taps can be set in the config > performance menu.
[Shift] + (Knob 1)	Tempo BPM	Turn to adjust the global beats per minute to a value between 20-300 BPM. Available sequencer main page.
Seq [1] - [8]	Select sequencer	Select a sequencer to edit.
[Mute] + Seq [1] - [8]	Sequencer On/Off	Activate or deactivate the selected sequencer for playback. Unlit = deactivated.
[Shift] + Seq [1] - [8]	Sequencer On/Off	When mute mode is latched on using double tap, select a sequencer using shift.
[Mute] + Column 1	Sequencer On/Off	Activate or deactivate the playback for the selected track when in a multitrack sequencer. Unlit = deactivated.
[Shift] + [Stop] - stopped	Sync mode	Play must be stopped. Synchronisation mode. Internal, External MIDI TRS & BLE, USB MIDI or Analog Clk.
[Shift] + [Stop] - playing	Sequencer reset	Only when playing. Resets the sequencer on the punch in quantization interval.
[Shift] + (Knob 3)	Set Scale	Choose a scale from the library of options. Scale can be copied with copy + tap knob 3. Hold paste + knob 3 to paste.
[Shift] + (Knob 4)	Set Root Note	Choose a root note. Root can be copied with copy + tap knob 4. Hold paste + knob 4 to paste.
[Page]	Select step range page	Tap page to show step range. Pages 16, 32, 48 and 64 lit white Tap again for 80, 96, 112, 128 lit turquoise.
Seq [1] - [8] + [Page]	Select step range page	Selects Pages 80, 96, 112, 128 lit turquoise.
[Shift] + [Track]	Follow mode on/off	Selects the visual tracking to keep the playhead across each page in view while playing.
Tap & Turn (Oct)	Adjust grid note range	Knob 2 changes the grid octave range by scrolling up/down. Note pitch remains the same but the grid view is changed.
[Track] + (Knob 1)	Adjust grid note range	Knob 1 changes the grid octave range by scrolling up/down. Note pitch remains the same but the grid view is changed.
[Init] + [Page]	Set start page	Sets the start point to a page for steps 16, 32, 48, 64. Example [Init] + [32] starts at step 17 on page '32'.
[Init] + [Pad]	Set start step	Sets the step start point within the page. Example, [End] + Col 2 [Pad] on page '16' sets start to step 2.
[End] + [Page]	Set length/end page	Sets the end point and hence the length to a page for steps 16, 32, 48, 64 etc. Example [End] + [32].
[End] + [Pad]	Set length/end step	Sets the end point hence the length in steps within the page. Example, [End] + Col 8 [Pad].
[Init] or [End] + (Knob 2)	Set the start step	Select the precise start point step.
[Init] or [End] + (Knob 3)	Set the end step	Select the precise end point step.
[Init] + [End]	Loop mode	Loop on/off. Hold start [Pad] + end [Pad] of each column to set the loop range. Use same pad columns to loop 1 step.
Seq [1] - [8] + [Copy]	Copy sequencer	Copy the selected sequencer to the clipboard.
Seq [1] - [8] + [Paste]	Paste sequencer	Paste the previously copied sequencer from the clipboard into the selected sequencer. Depends on seq mode.
[Shift] + [Paste]	Clear sequencer	Hold and quick press to clear of the sequencer pattern.
[Shift] + [Paste] > 2 sec	Fully clear the sequencer	Hold for > 2 seconds to perform a full clear of the sequencer pattern and all settings.
[Shift] + [Play] > 2 sec	Try it and see !	

Step & Grid Commands		
Shortcut	Command	Description
[Keyboard]	Keyboard layout	Switches the grid pads to a keyboard, piano style layout of drum pad layout for multitrack mode..
[Pad]	Place a step event	Tap a grid pad to place and select a step event. For example to add notes to a pattern.
[Pad] + [Pad]	Create tie - First + Last	Hold <u>first</u> grid pad + tap <u>last</u> grid pad, same row. Places a note tie for the duration of steps.
[Pad] + [Pad]	Repeats - Last + First	Hold <u>last</u> grid pad + tap <u>first</u> grid pad, same row. Places a repeat or random note sequence. Option in config.
[Mute] + [Pad]	Mute step	Mutes or unmutes the selected step immediately when the button combo is pressed.
[Pad] + Tap (Vel)	Mute step	Mutes or unmutes the selected step immediately when the velocity knob is pressed.
Tap & Turn (Oct)	Adjust grid note range	Knob 2 changes the grid octave range by scrolling up/down. Note pitch remains the same but the grid view is changed.
[Pad]	Open step options	Selects the primary step options and the settings for the selected step.
[Pad] [Page]	Navigate step pages	With a pad held, pressing step will cycle through the additional parameter submenus.
[Shift] + [Pad]	Open step option menu	Selects the additional step submenu and the settings for the selected step. Multiple pages may exist.
[Copy] + [Pad]	Copy the step / steps	Copies the step and settings to the clipboard. Multiple steps can be copied while holding copy. Also use [Pad] + [Copy].
[Paste] + [Pad]	Pastes the step / steps	Pastes the copied steps from the clipboard into the grid positioned based on first step copied. Based on seq mode.
[Shift] + [Copy]	Duplicates seq steps	Duplicates the current page of steps into the following page. Doubles the sequence.
[Page] + [Copy]	Copy pattern page	Copies the page of steps. Pages 16, 32, 48 and 64 lit white Tap again for 80, 96, 112, 128 lit turquoise
[Page] + [Paste]	Paste pattern page	Pastes the copied page of steps into current page. Pages 16, 32, 48 and 64 white, tap again for 80, 96, 112, 128 turquoise
[Shift] + [Page]	Shift seq on the grid	Moves the sequencer around the grid. Pages 16, 32, 48 and 64, operate as navigation arrows for the secondary option.
[Shift] + [Init]	Multiply current seq	Multiplies the current sequencer time division x 2 on each combo button press.
[Shift] + [End]	Divide current seq	Divides the current sequencer time division / 2 on each combo button press.
[Shift] + [Page]	Expand sequence	Buttons activate an expand by zooming into the sequencer. Time division halves.
[Shift] + [LFO]	Condense sequence	Buttons condense the sequencer by zooming out of the sequencer. Time division doubles. Destructive action.
[Shift] + [Mute]	Nudge menu	Open the nudge menu to offset the timing backwards or forwards of all sequencer notes.
[Shift] + [Mute] x2	Time bend menu	Open the time bend menu to affect the speed up or down of all sequencers.
[Shift] + [Flow]	Groove menu	Opens the groove options.
[Shift] + [Gen]	CV Gate configurator	Presents the grid as a CV Gate configurator to assign output CV and Gate channels to sequencers.

Arranger Commands		
Shortcut	Command	Description
[Arranger]	Open arranger	Opens the arranger too to edit and create songs. Does not activate the arranger on or off.
[Shift] + [Arranger]	Arranger On/Off	Turns the arranger on or off. When on, the song can be played. When stopped this is automatically set to off.
Tap (Load)	Load Song	Press knob 1 to open the browser. Navigate and load a song.
[Load] + [Pad]	Pattern override	Hold [Load] button + tap a pad in order to change its pattern while the arranger is on and song is playing.
Tap (Save)	Save Song	Press knob 2 to open the browser. Navigate and save a song.
(M)	Set the master lane	Turn knob 3 to set the master lane for a song.
(↔)	Navigate grid	Turn knob 4 to move through the grid columns left / right
[Pad]	Change or edit pattern	Hold a pad to open the edit menu. The pattern can be changed and configured from the grid or menu.
[Play]	Play song	Plays a song, not a pattern, when in arranger view. Tap a pad while playing to manually clip launch a pattern. [Stop] to stop.
[Copy] + [Pad]	Copy pattern slot	Copies and individual slot when in arranger view.
[Paste] + [Pad]	Paste pattern slot	Pastes the copied pattern slot to the selected pad. Must be in in arranger view.
[Shift] + (Clear)	Clear song	Clears the current song.
[Pad] + [64]	Shift pattern right	Move the pattern to the right on the grid.
[Pad] + [16]	Shift pattern left	Move the pattern to the left on the grid.

# Index

## A

Accumulator 186, 188  
Analog Drum Application 248  
Analog Synth Voice 249  
Architecture 9  
Arpeggiator 7, 102, 104, 135, 156  
Arranger 7, 222, 224  
Arranger Launch Quantization 14  
Arranger Master Seq 14  
Auto Sync 258  
Automation 203

## B

Back 6, 17  
Bank Change 232  
Battery 10  
Bluetooth 255

## C

Calibration 273–274  
CC 209  
CC Destinations 212  
Channel Multiplex 189  
Charging 10  
ChMx 189  
Chord 117, 124, 148, 154, 216

Chord Palette 152  
Chord Quality Palette 153  
Chord Recognition 99  
Chromatic 98  
Clear 13, 72  
Clip Launch 222, 231  
Clock 8, 41, 245, 250, 258  
Colors 35, 272  
Condense 67  
Config menu 17  
Copy 7, 14, 71, 130, 134, 161  
CV 5, 8, 208  
CV Gate 6, 236, 243  
CV Output 238

## D

Device Mode 254  
Display 16  
Domino 124, 177, 215  
Drum View 142, 146  
Drunk 69  
Duplicate 70

## E

Encoders 16  
End 7, 64–65, 100

# Index

Euclidean Pattern 78, 80, 107, 145

Expand 67

## F

Fills 115

Firmware Update 270

Flow 6, 108

Follower mode 37, 41

## G

Gate 5, 8, 44, 47, 173

Gate Output 243

Generator 6, 78, 145

Glide 176

Global Launch Quantization 54

Global Quantization 14

Grid 8, 18

Groove 6, 76

Groove Templates 76–77, 268–269

## H

Harmonizer 190

HDMI 5

Hold mode 103

Host Mode 254

## I

Init 7, 64–65, 100

Instrument Definitions 200, 260, 268–269

Interval 169

Isomorphic 98

## K

Keyboard 7, 110

Keyboard Mode 98

Knob 6, 16

## L

Latency 257

Launch Quantization 222, 230

LEDs 272

Length 64

LFO 7–8, 139, 196, 210, 242

Load 7, 11, 14, 88

Loop 100–101, 116

## M

Master Lane 222, 231

Master Scale 58

Matriceal 124, 162, 217

microSD 5, 10–11, 14–15

MIDI 5, 8, 209, 252

MIDI Input channel filtering 87

MIDI Input monitor 17, 259

MIDI Input Note Filtering 144

# Index

MIDI Player 14, 124, 184  
MIDI Remote Control 121  
Modulation 6, 196, 201, 242  
Modulation Matrix 205, 218  
Mono 124, 128, 215  
Monome 121  
Multitrack 124, 137, 217  
Mute 6, 35, 42, 114

## N

Note 168  
Nudge 6, 73

## O

Octave 18, 44, 172  
OXI App 77, 260, 266–267, 270  
OXI Pipe 251  
OXI Split 2 256

## P

Page 7, 18, 37  
Paste 7, 71, 130, 134, 161  
Pattern 8, 225  
Pendulum 69  
Perform 6, 113  
Pipe 5  
Play 6, 40

Playback Direction 69  
Poly 124, 131, 216  
Pong 69  
Port (A-C) Merge 87  
Ports 256  
Power 5, 10  
Preview 17, 98  
Probability 50–51, 174  
Program Change 232  
Project 6, 8, 11, 14, 269  
Project Backup 267  
Pulses 170

## Q

Quick Assign 219

## R

Random Generator 82  
Random Perform 111  
Randomize 68–69, 111, 139  
Randomizer 7  
Record 6, 40, 84, 86, 203  
Record Quantization 87  
Redo 7, 17  
Rename 12, 92, 94  
Repeat 44, 48

# Index

Retrigger 48, 175

Roller 110

Root 45, 56

Rotate 70, 115

## S

S-Trig 244

Saga 124, 181, 217

Save 7, 11, 14, 88

Scale 45, 56–57, 268–269

Scale Quantization 58

SD Card 269

Sequencer 6, 8, 16, 18, 35, 38

Shift 6, 17

Snapshot 8, 101, 120

Song 8, 225–226

Specifications 2

Step 7–8, 18

Step Recording 84

Step Setup 39

Stochastic 124, 157, 217

Stop 6, 41

Swing 45, 55, 75

Synchronization 41, 257

## T

Templates 93–94

Tempo 45, 54

Tie 18, 43

Time Bend 74

Time Division 66, 68

Track 7–8, 37–38

Transport 40

Transpose 70, 114, 130, 133, 151

Trigger 51

Troubleshooting 271

TRS Adapter 3

## U

Undo 7, 17

## V

V-Trig 244

Velocity 44, 46, 50, 171

Voice 8, 148, 238

## W

Wave Shapes 210–211

### **DECLARATION OF CONFORMITY**

#### **SPECIAL MESSAGE SECTION**

This product utilizes rechargeable batteries. DO NOT connect this product to any power supply or adapter different than one described in the manual or specifically recommended by OXI Instruments.

This product should be used only with the components supplied or, in case a non-official accessory is used, please observe that the specifications are the same as the official ones.

**IMPORTANT:** Don't try to open or disassembly the OXI One. For any technical problem it may have, please contact OXI Instruments for further information. Opening or disassembling the OXI One will void your warranty.

#### **FCC INFORMATION (U.S.A)**

##### **1. IMPORTANT NOTICE: DO NOT MODIFY THIS UNIT!**

This product meets FCC requirements once it is produced and assembled. Modifications not expressly approved by OXI Instruments may void your authority, granted by the FCC, to use the product.

This device complies with part 15 of the FCC Rules. Operation is subject to the following two conditions: (1) This device may not cause harmful interference, and (2) this device must accept any interference received, including interference that may cause undesired operation.

Contains FCC ID: 2A094-MK02

##### **2. IMPORTANT**

When connecting this product to accessories and/or another product use only high- quality shielded cables. Cable/s supplied with this product **MUST** be used. Follow all installation instructions. Failure to follow instructions could void your FCC authorization to use this product in the USA.

### 3. NOTE

This equipment has been tested and found to comply with the limits for a Class B digital device, pursuant to part 15 of the FCC Rules.

These limits are designed to provide reasonable protection against harmful interference in a residential installation.

This equipment generates, uses and can radiate radio frequency energy and, if not installed and used in accordance with the instructions, may cause harmful interference to radio communications.

However, there is no guarantee that interference will not occur in a particular installation. If this equipment does cause harmful interference to radio or television reception, which can be determined by turning the equipment off and on, the user is encouraged to try to correct the interference by one or more of the following measures:

- Reorient or relocate the receiving antenna.
- Increase the separation between the equipment and receiver.
- Connect the equipment into an outlet on a circuit different from that to which the receiver is connected.
- Consult the dealer or an experienced radio/TV technician for help.devices.

### DECLARATION OF CONFORMITY

The full text of the US declaration of conformity is available at the following internet address: [www.oxiinstruments.com/](http://www.oxiinstruments.com/)



### EUROPE

This product complies with the requirements of **European Directive 2014/53/EU & Directive 2011/65/EU**.

The full text of the EU declaration of conformity is available at the following internet address [www.oxiinstruments.com/](http://www.oxiinstruments.com/)



### ENVIRONMENTAL ISSUES:

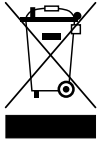

This symbol indicates that this product should not be treated as domestic waste. Once its useful life has ended, it must be taken to a relevant collection point for the recycling of electrical appliances. Through the correct recycling of batteries and electrical devices, we contribute to avoiding risks to environmental health and safety.

Product Disposal Note: If this product is damaged beyond repair or, for any reason, its useful life is deemed to have expired, please inform yourself about local, state and European regulations regarding the proper disposal and recycling of products containing lead, batteries, plastics, among other materials, as well as collection points for these types of products.



These symbols indicate that this product contains batteries and cannot be disposed as domestic waste. Once its useful life has ended, it must be taken to a relevant collection point for the correct recycling of its batteries.

This product is classified as **Radio Equipment**.

### SERIAL NUMBER LOCATION:

The serial number is located on the instrument body, in the label placed in the bottom side.

### TERMS OF WARRANTY

#### REFUND POLICY (only in European Union)

The consumer has a total of 14 days from the acquisition of the OXI One to be able to return the product thus receiving a full refund of the price of it. The product must be in the same state and with all the original content in order to receive a full refund.

Shipping costs will be paid by the customer.

#### WARRANTY

OXI Instruments warrants the included hardware product and accessories against defects in materials and workmanship for two years from the date of original purchase. Unless proven otherwise, it will be presumed that the breaches of conformity manifested in a period of six months from the delivery of the product already existed on that date.

The warranty will not cover the repairing costs of the following cases:

Misuse of OXI One, whether subject to extreme conditions, as using it incorrectly.

Improper handling of the product.

Normal wear and tear, nor damage caused by accident or abuse.

Malfunction due to the use of accessories not authorized by OXI Instruments.



## Changelog

OS & Manual	Feature Update	Manual Update
1.1.0 a-i	Initial first release	
1.1.0j	<ul style="list-style-type: none"> <li>• BPM Tempo Nudge forwards and backwards</li> <li>• Solo option for multitrack in performance view</li> <li>• Matriceal trigger step undo / redo option</li> <li>• Matriceal randomization of each matrices.</li> <li>• Arp reset. Pattern position, groove, all or none.</li> <li>• CV/Gate Polyphonic voicing modes.</li> <li>• CC Mod to CV operates when stopped.</li> </ul>	<ul style="list-style-type: none"> <li>- Nudge added. Page 54</li> <li>- Solo for multitrack in performance view. Pages 109, 131.</li> <li>- Undo / Redo. Page 156</li> <li>- Randomize. Pages 108, 153</li> <li>- Arp Reset. Pages 99-101</li> <li>- Voicing. Pages 207, New - Page 208, Page 244</li> <li>- CC Mod comment on Page 178</li> <li>- Mod recording: Added more clarity on behavior. Page 177.</li> <li>- Incoming PC Change in the Arranger. Page 202.</li> <li>- Calibration. Added pages 243-244.</li> <li>- Changelog added (this table) for OS and content updates.</li> <li>- Accumulator. Additional clarification. Pages 122-123</li> <li>- Minor corrections. Page 56</li> </ul>
1.1.0k		<ul style="list-style-type: none"> <li>- Chord Mode - Bass Note clarification for independent MIDI channel. Page 142.</li> </ul>
0.19.07 b	<ul style="list-style-type: none"> <li>• Groove parameters expanded including length</li> <li>• Project master scale added.</li> <li>• Accumulator added to poly sequencer mode.</li> <li>• Multiple step editing enhancements.</li> </ul>	<ul style="list-style-type: none"> <li>- Groove additional parameters incl length. Page 76-77.</li> <li>- Load all pattern option added. Page 86.</li> <li>- Project master sequencer for scale and root. Page 14, 58.</li> <li>- Accumulator Hold &amp; Poly Mode. Page 122, 124, 127.</li> <li>- Mono to Poly Seq. Page 119, 121</li> <li>- Poly Chord Mode - Page 112, 131.</li> <li>- Multipress editing. Page 39, 44.</li> <li>- Typo fixes and clarity additions. Page 11, 53, 82, 85, 121</li> </ul>
1.0.1 a	<ul style="list-style-type: none"> <li>• Only relevant, edited data is saved with projects and save all functions.</li> <li>• Keyboard chord recognition.</li> <li>• Keyboard note recording buffer added.</li> <li>• Random generator 'Inver' parameter rename.</li> <li>• Random perform. Poly mode scope per note or per column options.</li> <li>• Step recording in Poly mode.</li> <li>• Various fixes and improvements including accumulator storage, gate trig, instrument definition and pattern integrity, BPM.</li> </ul>	<ul style="list-style-type: none"> <li>- Save efficiency. Page 11.</li> <li>- Keyboard chords. Page 95.</li> <li>- Keyboard recording buffer - Page 95.</li> <li>- Random Generator - Density, Inver renamed to flip. Page 81.</li> <li>- Random Perform - Poly mode scope feature. Page 107-108.</li> </ul>
1.0.12 a		<ul style="list-style-type: none"> <li>- Various clarity updates, typo fixes and running order.</li> <li>- Moved keyboard recorder to MIDI capture in recording section. Page 83 (new page, subsequent page reorder)</li> <li>- Further clarification on off grid notes. Page 37, 123, 145.</li> </ul>
2.0	New Major OS Update. New sequencer modes, modulation system changes, chord palette, various workflow and quality of life improvements and fixes.	<ul style="list-style-type: none"> <li>- Reworked the entire modulation section.</li> <li>- Reworked the entire modes section plus new modes.</li> <li>- Reworked perform function.</li> <li>- Quick assign added.</li> <li>- All screen graphics and parameters updated.</li> </ul>



Copyright © 2026 by OXI Electronic Instruments SLU

© 2023 OXI ELECTRONIC INSTRUMENTS SLU. All rights reserved. OXI INSTRUMENTS and the OXI logo are registered trademarks of OXI INSTRUMENTS in the UE and registered in many other countries. OXI ONE is a trademark of OXI INSTRUMENTS. Design and specifications subject to change without notice. The OXI ONE may not be authorized for use in some countries.

May 2026 - OXI ONE MKII OS 2.0 Manual Ver a

[www.OXIinstruments.com](http://www.OXIinstruments.com)

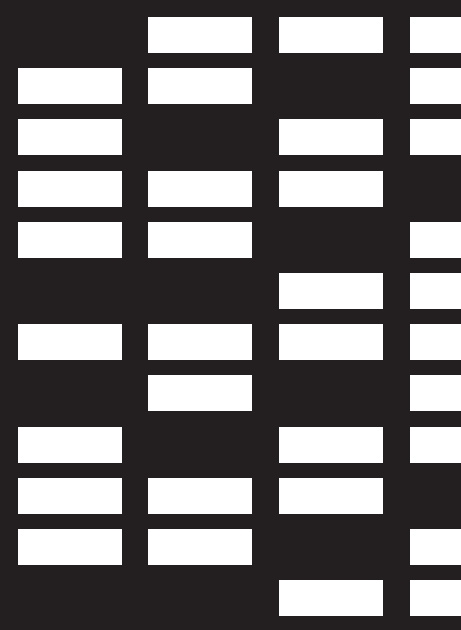
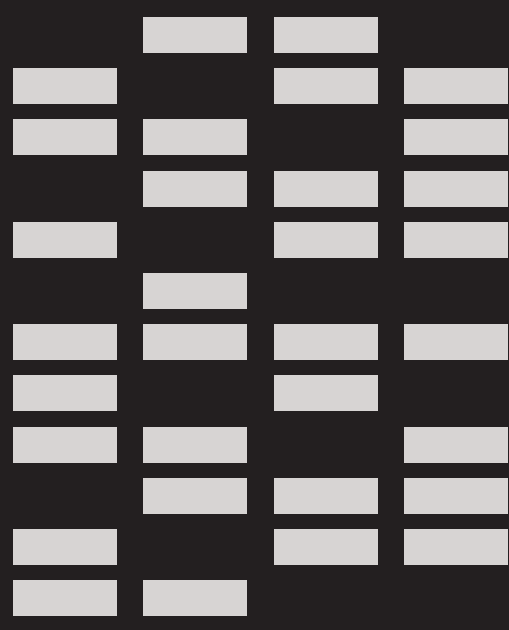
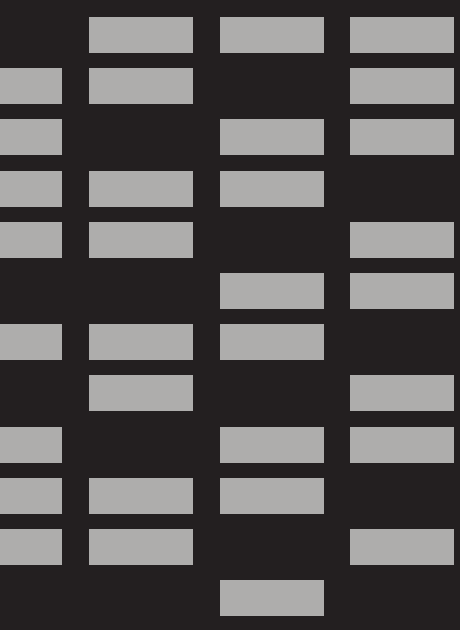

[www.oxiinstruments.com](http://www.oxiinstruments.com)